

ASSEMBLY AND OPERATION MANUAL

AC31 Adapter

Supplement to the Existing Documentation

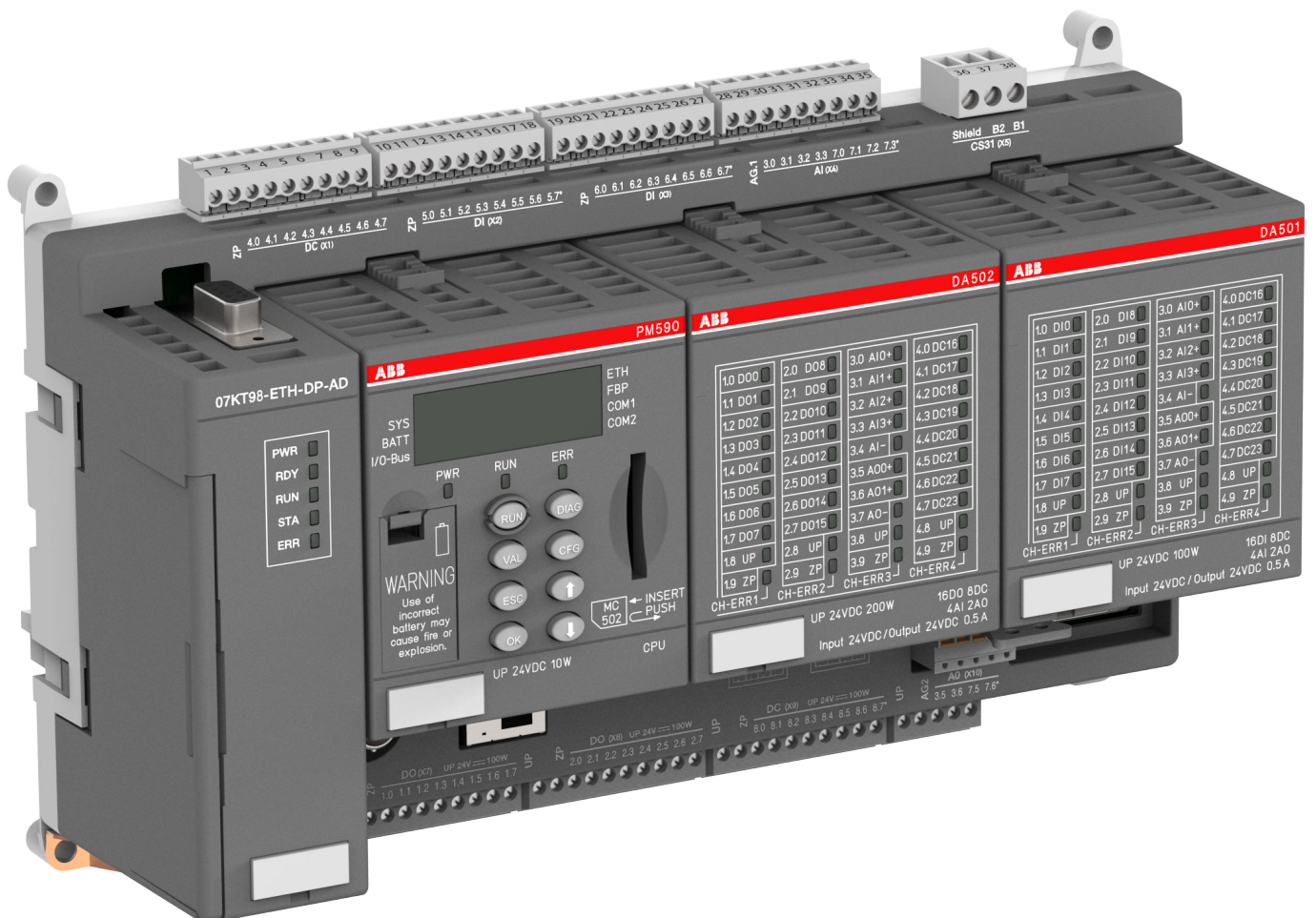

Table of contents

1	AC31 adapters	3
1.1	Introduction.....	3
1.2	Overview of AC31 adapters (replacement devices).....	3
1.3	System data and CS31 bus system data.....	4
1.3.1	System data of the AC31 adapters.....	4
1.3.2	CS31 bus system data.....	10
1.4	Replacement devices: CPU.....	19
1.4.1	Replacement device 07KT9x-AD.....	20
1.5	Replacement devices: I/O modules.....	59
1.5.1	Replacement device 07AC91-AD.....	60
1.5.2	Replacement device 07AC91-AD2.....	74
1.5.3	Replacement device 07AI91-AD.....	91
1.5.4	Replacement device 07DC91-AD.....	110
1.5.5	Replacement device 07DC92-AD.....	126
1.5.6	Replacement unit DC501-CS31-AD.....	143
2	Index	168

1 AC31 adapters

1.1 Introduction

Replacement devices for AC31

The modular product line of the AC31 adapter series includes modular exchange components for control systems of the Advant Controller 31 (90 series). The simple exchange of individual components allows existing customers to maintain their PLCs in a quick and cost-effective manner. Extensive software modifications are not required.

Each replacement device is based on trend setting technologies of the AC500 series. Therefore, by exchanging components it is not only possible to replace the existing device, but also to profit from new functions and improved product quality.

Note regarding product documentation

During the development of the AC31 adapter series, care was taken to keep the device configuration identical to the configuration of the AC31 devices. Consequently, the technical documents for the AC31 devices are still valid and serve as reference:

- [Software description \(only available in English\)](#)
- [System description Advant Controller 31](#)

Only unavoidable deviations, for example due to technical limitations, are described in this document.



CAUTION!

Installation and maintenance work on the device must be performed by qualified personnel in line with the recognized technical rules, regulations and relevant standards such as EN 60204-1.



For safety instructions, please refer to [Regulations for the erection of installations](#).

1.2 Overview of AC31 adapters (replacement devices)

An AC31 adapter (replacement device) is available for the following AC31 devices of the 90 series (existing devices):

Existing devices: AC31 (90 series)	Replacement devices: AC31 adapters	Replacement device is based on the following AC500 device
CPU devices:		
07KT94-ARC	07KT94-ARC-AD *)	PM590, DA501 and DA502
07KT98-ARC	07KT98-ARC-AD	
07KT98-ARC-DP	07KT98-ARC-DP-AD	
07KT98-ARC-ETH	07KT98-ARC-ETH-AD	
07KT98-ETH-DP	07KT98-ETH-DP-AD	
--	07KT98-ARC-ETH-DP-AD	

*) Customer specific product not available for current sales

Existing devices: AC31 (90 series)	Replacement devices: AC31 adapters	Replacement device is based on the following AC500 device
I/O modules:		
07DC91	07DC91-AD	DC532
07DC92	07DC92-AD	DO524
07AC91	07AC91-AD (8-Bit)	AO523
07AC91	07AC91-AD2 (12-Bit)	AX522
07AI91	07AI91-AD	AI523
DC501-CS31	DC501-CS31-AD	DC532

1.3 System data and CS31 bus system data

The system data described in this chapter are valid for the following replacement devices:

- 07KT94-ARC-AD
- 07KT98-ARC-AD
- 07KT98-ARC-DP-AD
- 07KT98-ARC-ETH-AD
- 07KT98-ETH-DP-AD
- 07KT98-ARC-ETH-DP-AD
- 07AC91-AD
- 07AC91-AD2
- 07AI91-AD
- 07DC91-AD
- 07DC92-AD
- DC501-CS31-AD

Please also observe the CS31 bus system data ↗ *Chapter 1.3.2 “CS31 bus system data” on page 10.*



The devices of the AC31 adapter series do not have marine approval.



NOTICE!

AC31 adapter I/O modules must only be used with an ABB CPU with master CS31 bus (e.g. AC31 07KT9x, AC31-Adapter 07KT9x-x-x-AD or AC500 CPU).

1.3.1 System data of the AC31 adapters

1.3.1.1 Operating and environmental conditions

Table 1: Supply voltages

Voltages according to IEC 61131-2:		
24 V DC	Process and supply voltage	24 V DC (-15 %, +20 % without residual ripple)
	Absolute limits	19.2 V ... 30 V incl. residual ripple

	Residual ripple	≤ 5 %
	Polarity reversal protection	10 s (test duration), permanently present on AC31 adapters
Bridging time for power interruptions according to IEC 61131-2:		
	DC supply	Interruption < 10 ms Time between 2 interruptions > 1 s



CAUTION!

System damage caused by voltage!

Exceeding the maximum supply or process voltage (>30 V DC) results in permanent system damage (destruction).

Table 2: Operating and environmental conditions

Temperature:	
-> Operation	0 °C ... +55 °C (vertical mounting position, terminals upward and downward)
-> Storage	-40 °C ... +75 °C
-> Transport	-40 °C ... +75 °C
Humidity	max. 95 %, without condensation
Air pressure:	
-> Operation	> 800 hPa / < 2000 m
-> Storage	> 660 hPa / < 3500 m

1.3.1.2 Creepage distances and clearances

The creepage distances and clearances correspond to overvoltage category II, pollution degree 2.

1.3.1.3 Test voltages for type test

Test voltages for type test according to IEC 61131-2:

Table 3: Impulse testing

Data	Voltage	Duration
24 V circuits (supply, 24 V inputs/outputs), when galvanically isolated from other circuitry	500 V	1.2 / 50 μs
CS31 interface from other circuitry	500 V	1.2 / 50 μs
Ethernet	500 V	1.2 / 50 μs
ARCNET	500 V	1.2 / 50 μs
COM interfaces, galvanically isolated	500 V	1.2 / 50 μs
Enabling input, galvanically isolated	500 V	1.2 / 50 μs

Table 4: AC voltage tests

Data	Voltage	Duration
24 V circuits (supply, 24 V inputs/outputs), when galvanically isolated from other circuitry	350 V AC	60 s
CS31 interface from other circuitry	350 V AC	60 s
Ethernet	350 V AC	60 s
ARCNET	350 V AC	60 s
COM interfaces, galvanically isolated	350 V AC	60 s
Enabling input, galvanically isolated	350 V AC	60 s

1.3.1.4 Power supply units

For the supply of devices, use power supply units according to PELV specification.

1.3.1.5 Electromagnetic compatibility

Table 5: Immunity

Data	Value
Immunity against electrostatic discharge (ESD)	According to EN 61000-4-2, zone B, criterion B
-> Interference voltage with air discharge	8 kV
-> Interference voltage with contact discharge	4 kV
ESD with communication connectors	Ensure that any electrostatic charge is discharged prior to contact with the communication connectors (e.g. by touching an grounded metal object). Otherwise malfunctions may occur.
ESD module carrier connectors	Do not touch the plug connecting the module carrier on the bottom side of the device.
ESD external communication module interface	Do not touch the plug to the flat ribbon cable.
Immunity against the influence of radiated interference (CW radiated)	According to EN 61000-4-3, zone B, criterion A
-> Test field strength	10 V/m (except ITU transmission bands 87 MHz ... 108 MHz, 174 MHz ... 230 MHz and 470 MHz ... 790 MHz -> 3 V/m)
-> Maximum temporary deviation during irradiation	Analog current output signals max. 1.5 %. Devices affected: 07AC91-AD, 07AC91-AD2, 07KT94-ARC-AD, 07KT98-ARC-AD, 07KT98-ARC-DP-AD, 07KT98-ARC-ETH-AD, 07KT98-ETH-DP-AD, 07KT98-ARC-ETH-DP-AD
Immunity against transient interference voltages (burst)	According to EN 61000-4-4, zone B, criterion B
-> Voltage supply	2 kV
-> Enabling input	2 kV

Data	Value
-> Digital inputs/outputs	1 kV
-> Analog inputs/outputs	1 kV
-> CS31 bus	1 kV
-> Serial RS-232 interfaces (COM)	1 kV
-> ARCNET	1 kV
-> Ethernet	1 kV
-> I/O supply, DC out	1 kV
Immunity against the influence of power related interference (CW radiated):	According to EN 61000-4-6, zone B, criterion A
-> Test voltage	Zone B, also according to 10 V
Immunity against transient interference voltages with high energy (surge)	According to EN 61000-4-5, zone B, criterion B
-> Voltage supply DC, enabling input	0.5 kV CM / 0.5 kV DM *)
-> I/O supply, DC out	0.5 kV CM / 0.5 kV DM *)
-> Shielded buses	1 kV CM *)
-> I/O analog, I/O DC unshielded	1 kV CM / 0.5 kV DM *)
Emitted interference (radiation):	-
-> From radiated interferences	According to EN 55011, group 1, class A

*) CM = Common Mode, DM = Differential Mode



The devices of the AC31 adapter series do not have marine approval.

1.3.1.6 Mechanical data

Data	Value
Degree of protection	IP20
Housing	According to UL 94
Vibration resistance according to EN 61131-2	All three axes 2 Hz ... 15 Hz, continuous 3.5 mm 15 Hz ... 150 Hz, continuous 1 g
Vibration resistance with memory card plugged	15 Hz ... 150 Hz, continuous 1 g
Shock resistance	All three axes 15 g, 11 ms, semi-sinusoidal

1.3.1.7 Grounding

The AC31 adapter devices can be grounded as follows:

**Grounding of
 07AC91-AD,
 07AC91-AD2,
 07AI91-AD,
 07DC91-AD,
 07DC92-AD**

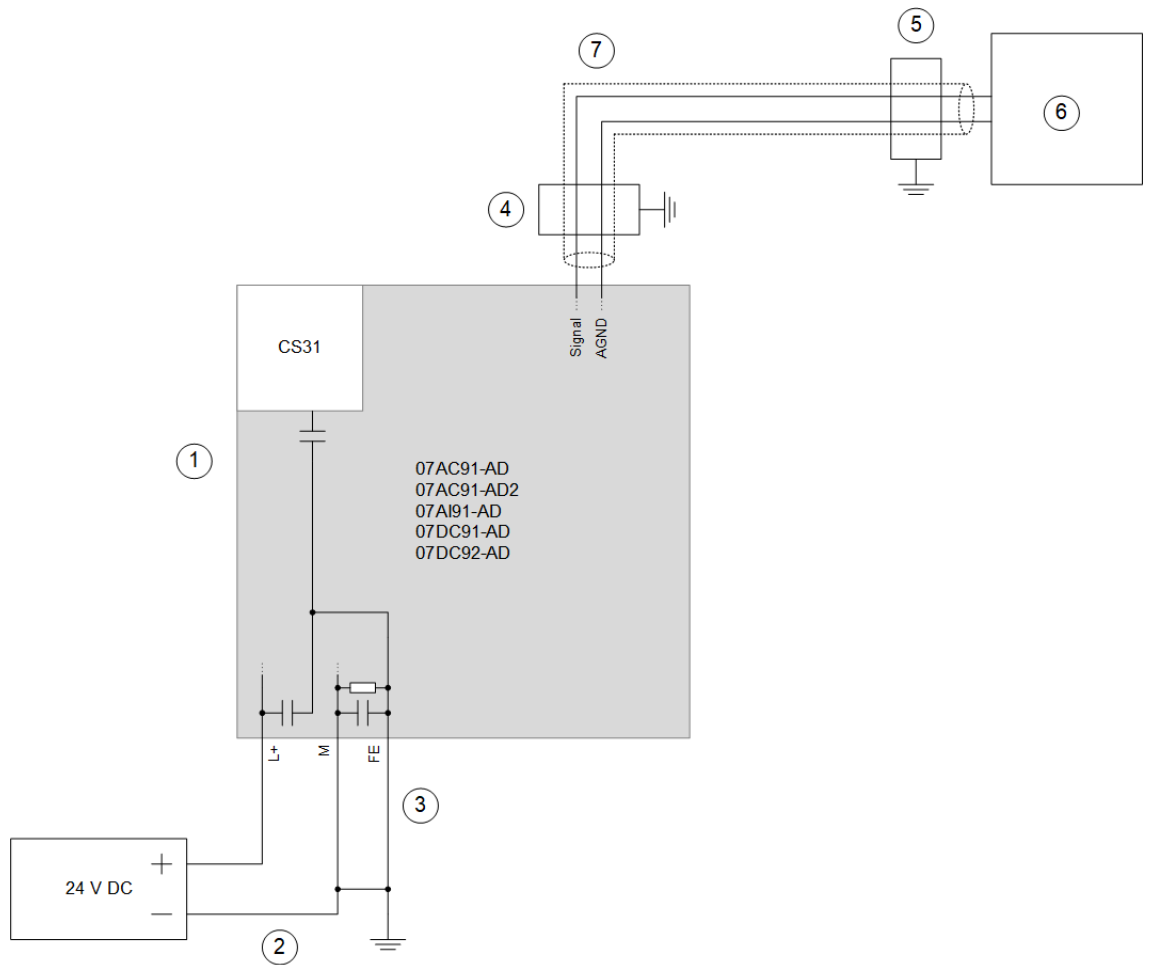

- 1 Capacitive grounding of the galvanically isolated CS31 interface (ground - surface)
 -> no grounding of the shield connection of the CS31 bus!
- 2 The process voltage is to be included in the grounding concept of the control system
- 3 Short connection (max. 25 cm) cross section 2,5 mm²
- 4 Direct grounding with clamp on the mounting plate (as close as possible to the AC31 I/O adapter)
- 5 Direct grounding with clamp on the mounting plate (as close as possible to the sensor/ actuator)
- 6 Sensor/ actuator
- 7 Analog signals

Grounding of DC501-CS31-AD

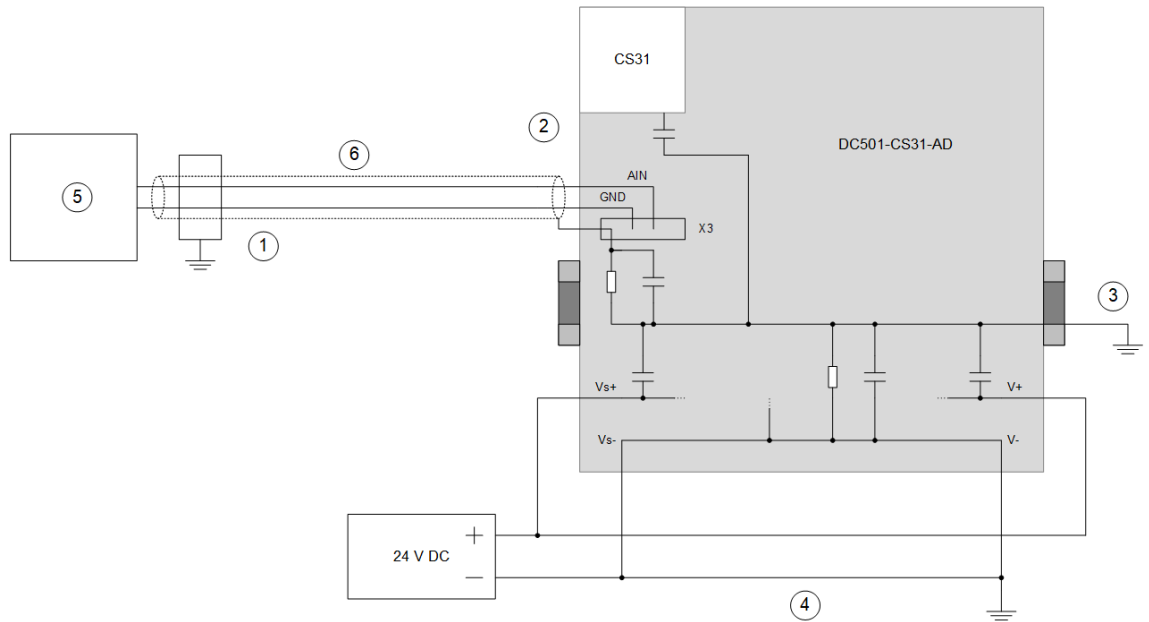

- 1 Direct grounding with clamp on the mounting plate (as close as possible to the sensor)
- 2 Capacitive grounding of the galvanically isolated CS31 interface (ground - surface)
-> no grounding of the shield connection of the CS31 bus!
- 3 Grounding via top-hat rail (or with 2 screws).
Cross-section area 10 mm².
- 4 The process voltage is to be included in the grounding concept of the control system!
- 5 Sensor
- 6 Analog signals

Grounding of CPU

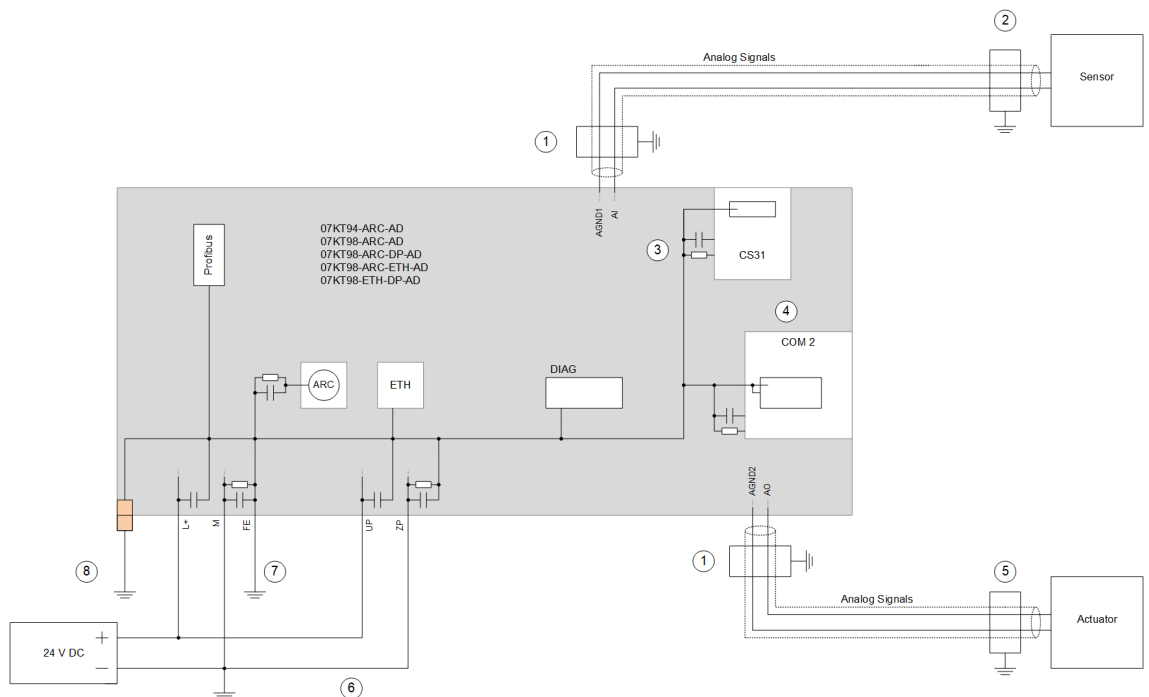

- 1 Direct grounding with clamp on the mounting plate (as close as possible to the central unit)
- 2 Direct grounding with clamp on the mounting plate (as close as possible to the sensor)
- 3 Capacitive grounding of the galvanically isolated CS31 interface (ground – surface)
- 4 Capacitive grounding of the galvanically isolated COM2 interface (ground – surface)
- 5 Direct grounding with clamp on the mounting plate (as close as possible to the CS31 slave)
- 6 The process voltage is to be included in the grounding concept of the control system!
- 7 Short connection (max. 25 cm).
- 8

- Cross section area 2,5 mm².
8 Short connection (max. 25 cm).
Cross section area 6 mm².



NOTICE!

The shield connection of the CS31 interface is connected to the FE!



When grounding the replacement devices, observe the following:

- *Install the AC31 adapter devices onto an grounded mounting plate to ensure a uniform reference potential of all equipment.*
- *Implement the connections between switchgear cabinet, mounting plate, PE rail and shield rail with low impedance.*
- *Install the lines in groups (power lines, power supply lines, signal lines, data lines).*
- *Use lines with braided cable shield for analog signals. Ground the shield on both sides and make sure that no compensation currents flow through the cable shield. For this purpose, use a potential equalization line with current carrying capacity, for instance on systems consisting of several switchgear cabinets.*

Further information concerning CS31 bus grounding: ↗ *Chapter 1.3.2.3 “Grounding” on page 13*

1.3.2 CS31 bus system data

1.3.2.1 Wiring

Table 6: Bus line

Data	Value
Configuration	2 cores, twisted, with common shield
Cross section	> 0.22 mm ² (24 AWG) Recommendation: 0.5 mm ² corresponds to Ø 0.8 mm
Twist rate	> 10/m (symmetrically twisted)
Core insulation	Polyethylene (PE)
Resistance per core	< 100 Ω/km
Characteristic impedance	approx. 120 Ω (100 ... 150 Ω)
Capacitance between the cores	< 55 nF/km (in case of higher capacitance values, the maximum possible bus length is reduced)
Terminating resistors	120 Ω ¼ W at both ends
Notes	Cables with PVC core insulation and core diameter of 0.8 mm can be used up to a length of approx. 250 m. In this case, the terminating resistor is 100 Ω. Cables with PE core insulation can be used up to a length of approx. 500 m.



The transmission rate used on the CS31 bus is 187.5 kBaud.

1.3.2.2 Bus topology

A CS31 bus always contains only one CS31 bus master to control the bus. Up to 31 CS31 slaves can be controlled by one bus. The CS31 bus master has no address, whereas the CS31 slaves can accept addresses in the range from 0 - 61, depending on CS31 slave type.

Possible CS31 bus masters:

- 07KT94-ARC-AD, 07KT94
- 07KT98-ARC-AD, 07KT98
- 07KT98-ARC-DP-AD
- 07KT98-ARC-ETH-AD
- 07KT98-ETH-DP-AD
- 07KT98-ARC-ETH-DP-AD

Possible CS31 slaves:

- 07AC91-AD, 07AC91
- 07AC91-AD2
- 07AI91-AD, 07AI91
- 07DC91-AD, 07DC91
- 07DC92-AD, 07DC92
- DC501-CS31-AD, DC501-CS31

The following diagram shows the bus topology with CS31 bus master on the side without shielding and grounding treatment:

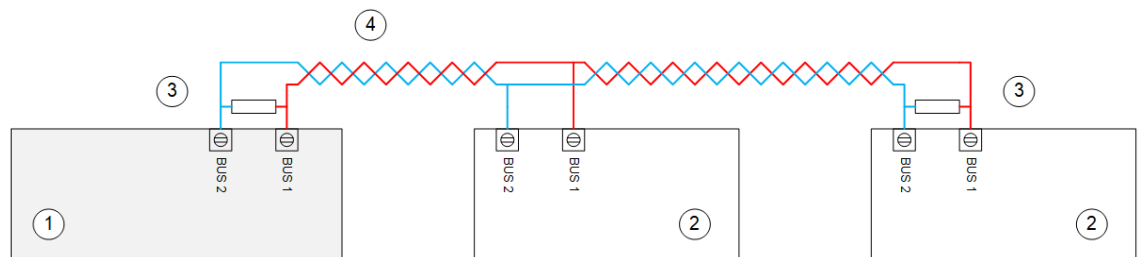

- 1 CS31 bus master
- 2 CS31 slave
- 3 120 Ω terminating resistor
- 4 CS31 system bus



The CS31 slave DC501-CS31-AD has an internal 120 Ω terminating resistor which can be connected by using a DIP switch. On the other CS31 slaves and the CS31 bus master, the terminating resistor must be installed externally by the user.

The following diagram shows the bus topology with CS31 bus master in the middle without shielding and grounding treatment:

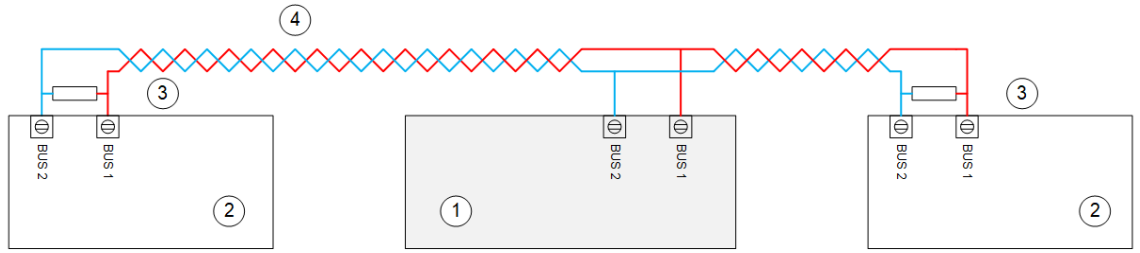

- 1 CS31 bus master
- 2 CS31 slave
- 3 120 Ω terminating resistor
- 4 CS31 system bus



CAUTION!
Risk of malfunctions!
 Spur lines are not allowed within the CS31 bus. Loop the bus line from module to module.

CS31 cable laying

Correct cable laying:

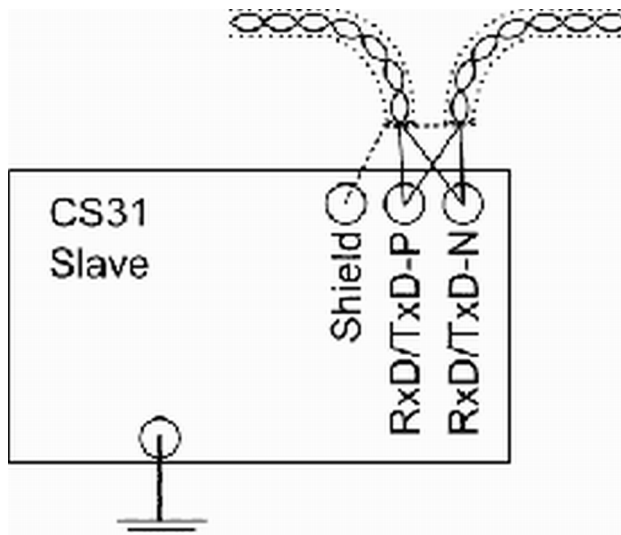

Incorrect cable laying:

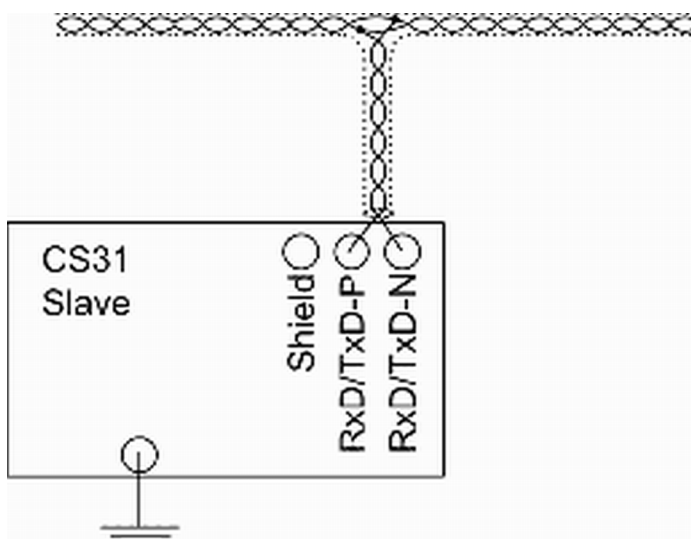

1.3.2.3 Grounding

In order to avoid disturbances, ground the cable shields directly.

Current carrying capacity Choose direct grounding if it can be ensured by means of current carrying metal connections (steel constructions, ground bars, etc.) that no potential differences can occur.

Direct grounding of CS31 bus master and CS31 slave:

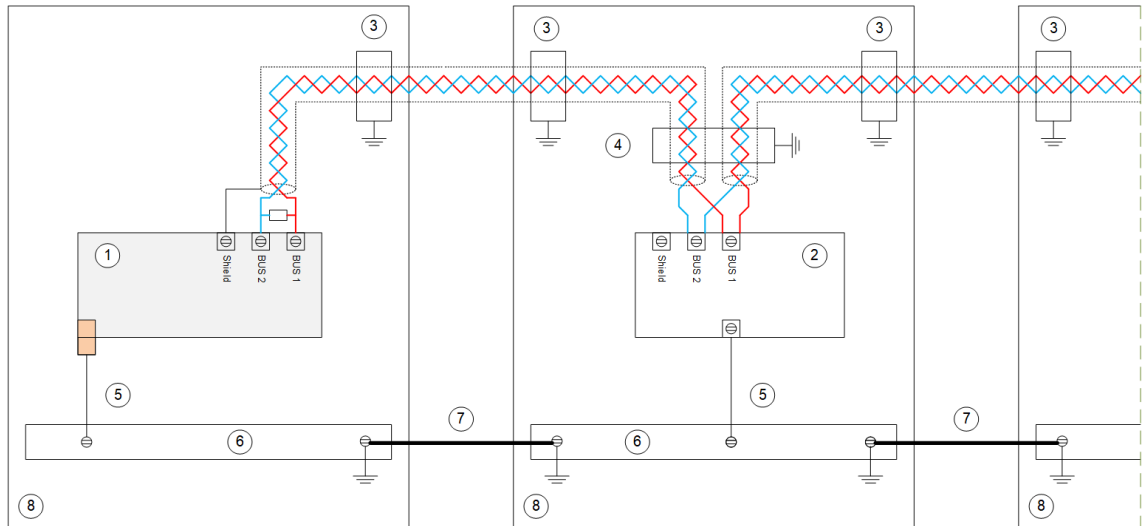

- 1 CS31 bus master
- 2 CS31 slave
- 3 Direct grounding at the control cabinet (entrance)
- 4 Direct grounding with clamp on the mounting plate (as close as possible to the CS31 slave)
- 5 Short connection (max. 25 cm).
Cross section area 2,5 mm².
- 6 Ground of the control cabinet
- 7 Current-conducting connection
- 8 Control cabinet



The shield connection of the CS31 bus master is internally connected to the ground terminal.

No current carrying capacity Apply capacitive grounding if system parts are not connected to each other in terms of their current carrying capacity. This prevents the flow of compensation currents through the cable shields.

Direct grounding of CS31 bus master and capacitive CS31 slave:

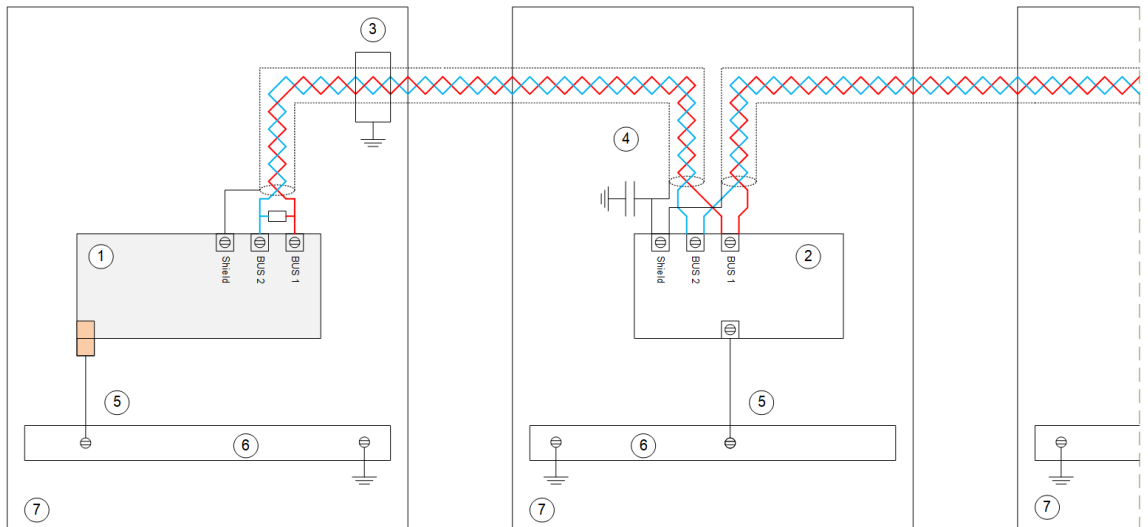

- 1 CS31 bus master
- 2 CS31 slave
- 3 Direct grounding at the control cabinet (entrance)
- 4 Capacitive grounding via 100 nF X condensator (directly on the metal sheet of the control cabinet)
- 5 Short connection (max. 25 cm).
Cross section area 2,5 mm².
- 6 Ground of the control cabinet
- 7 Control cabinet

 On the CS31 slave, the shield connection is not connected internally and thus not grounded. The shield connection can be used to connect the shields of two cables.

 VDE 0160 requires that the system's shield is grounded directly at least once.

1.3.2.4 Bus cycle time and data security

The communication via the CS31 bus is cyclic and controlled by the CS31 bus master.



Fig. 1: Format of request telegram of a CS31 bus master

In each cycle, the CS31 bus master successively polls all existing CS31 slaves at regular intervals, performs a diagnosis on one of the existing CS31 slaves and sends a request to search for added CS31 slaves. Thus, on one hand it is possible to maintain a continuous diagnosis of the proper network function and on the other hand to take all the newly added CS31 slaves into account.



Fig. 2: Format of response telegram of a CS31 slave

The CS31 slaves respond to the telegrams of the CS31 bus master with a response telegram (see diagram above). The data are indicated in the documentation of the individual devices (e.g. 07AC91-AD2). The telegram is ignored when a CS31 slave or a CS31 bus master detects a deviation between the received CRC and the self-calculated CRC. A CS31 bus error exists when 10 faulty telegrams are issued successively.

The bus cycle time is composed of a base time, the bus transmission times of the data of the individual CS31 slaves and the bus idle times between the individual telegrams.

During the base time, the CS31 bus master performs a diagnosis and searches for newly added CS31 slaves. This time depends on the control system (PLC / central unit) and is partially configurable:

- Devices 07KT94 and 07KT98: base time 2 ms
- Device 07KT94-ARC-AD: base time 10 ms *)
- Devices 07KT98-ARC-AD, 07KT98-ARC-DP-AD, 07KT98-ARC-ETH-AD, 07KT98-ETH-DP-AD, 07KT98-ARC-ETH-DP-AD:
Base time 5 ms to 100 ms (configurable in Automation Builder, parameter "Min update time")

*) The base time of device 07KT94-ARC-AD cannot be configured since the old programming environment (907 PC 331) must be used.

The bus transmission times of the data of the individual CS31 slaves can be determined as follows:

- Duration for the transmission of 1 byte = $(1/187.5 \text{ kBaud}) \times 8 = 43 \mu\text{s}$
- Determine number of data bytes (sending + receiving) from existing documentation
- Add 3 bytes for the transmission of the address and CRCs

Per CS31 slave, approx. 0.5 ms can be assumed as bus idle time. The CS31 bus master needs this time to process the data. This time depends on the computing power and on the implementation of the CS31 bus master. This time can vary between various firmware versions.

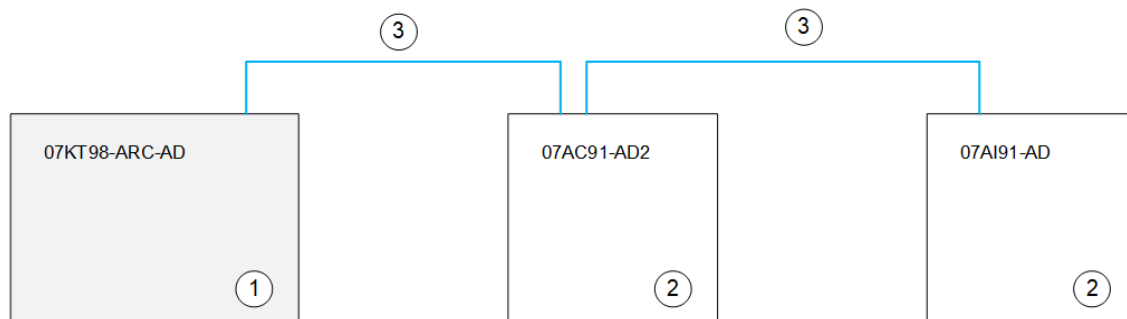

- 1 CS31 bus master
Min update time = 5 ms
- 2 CS31 slave
- 3 CS31 system bus

Table 7: Example: Bus cycle time

Base time	Min. update time = 5 ms		5000 μs
Bus transmission time 07AC91-AD2	Receiving 16 byte data	16 x 43 μs	688 μs
	Sending 16 byte data	16 x 43 μs	688 μs
	3 byte address + CRCs	3 x 43 μs	129 μs
Bus idle time	-	-	500 μs
Bus transmission time 07AI91-AD	Sending 16 byte data	16 x 43 μs	688 μs

	3 byte address + CRCs	3 x 43 μs	129 μs
Bus idle time	-	-	500 μs
Bus cycle time (sum)	-	-	8322 μs ≈ 8500 μs

1.3.2.5 Configuration

Below is a description of the configuration of the devices 07KT98-ARC-AD, 07KT98-ARC-DP-AD, 07KT98-ARC-ETH-AD and 07KT98-ETH-DP-AD, 07KT98-ARC-ETH-DP-AD in the Automation Builder software .

The configuration of the CS31 slaves takes place only by means of DIP switches ([AC500 V2 \(online\)](#)), whereby the configuration of the CS31 bus topology is carried out in the CS31 bus master.

 *The configuration of the devices 07KT94 and 07KT94-ARC-AD is carried out with the DOS program "907 PC 331". Further information on configuration is available in the existing documentation.*

Configure the COM1 interface as CS31 bus master:

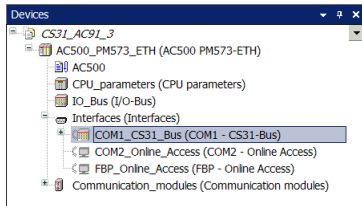

Fig. 3: CS31 bus master

The "Min update time" parameter can also be set on the CS31 bus master:

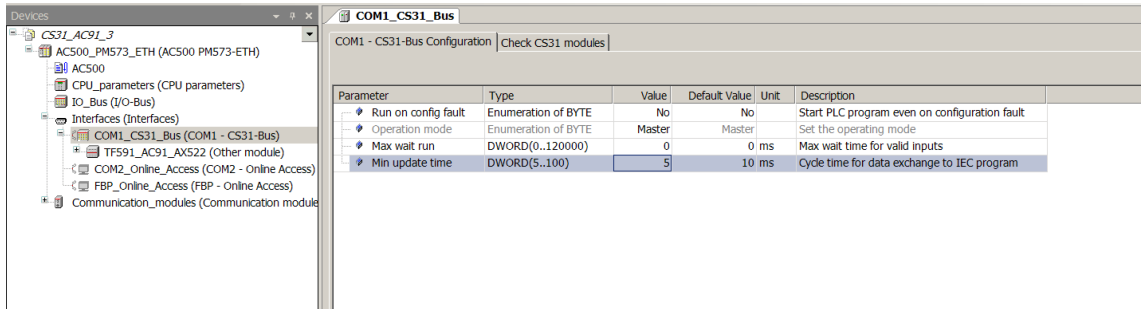

Fig. 4: Parameter configuration

The individual CS31 slaves must be configured in the tree structure under the CS31 bus master:

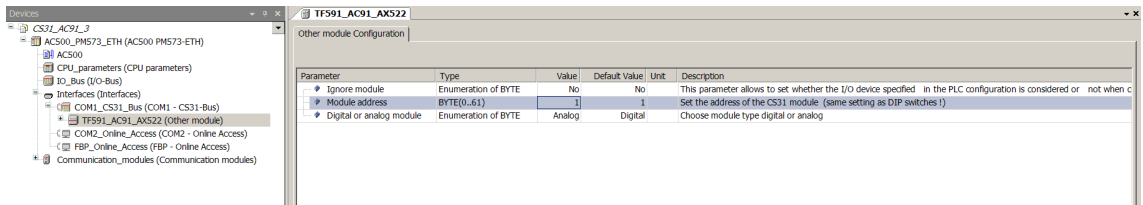

Fig. 5: CS31 slave

The module address must be set on each CS31 slave. Specify the same module address that has been selected with the DIP switches.

Set the CS31 slave type (analog/digital):

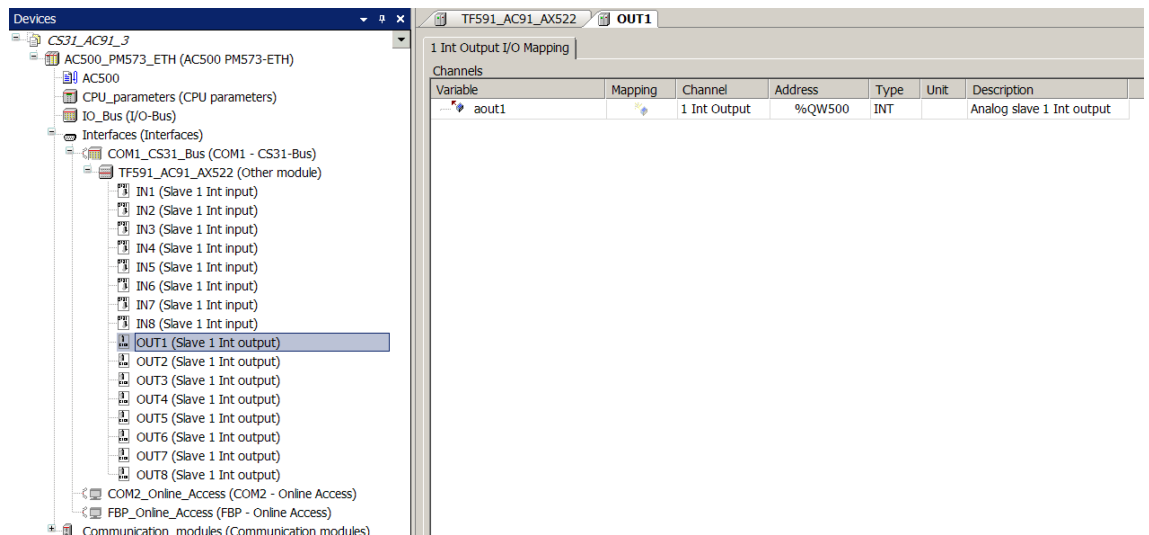

Fig. 6: CS31 bus slave configuration

The data must be configured in the tree structure under the CS31 bus slave. Information about the number of input and output data can be obtained from the respective documentation of the CS31 bus slaves.



If the data represent bipolar values (e.g. voltage from -10 V ... +10 V), the use of the data type INT is appropriate. In case of unipolar values (e.g. current from 0 mA ... 20 mA), the data type WORD can be used.

1.3.2.6 Diagnosis

For the diagnosis of the CS31 bus, various mechanisms are available in the CS31 bus master of the devices 07KT98-ARC-AD, 07KT98-ARC-DP-AD, 07KT98-ARC-ETH-AD, 07KT98-ETH-DP-AD and 07KT98-ARC-ETH-DP-AD:

- Diagnosis via the function block CS31_DIAG
- Diagnosis system of the AC500 series

For further information on both mechanisms, please refer to . Below, only a few special diagnosis functions of the AC31 adapter are addressed.

Function block CS31_DIAG:

In the 'State' column, the variable `byStateDiag` of the structure `strCS31_DiagOneModule` is indicated for every CS31 bus slave.

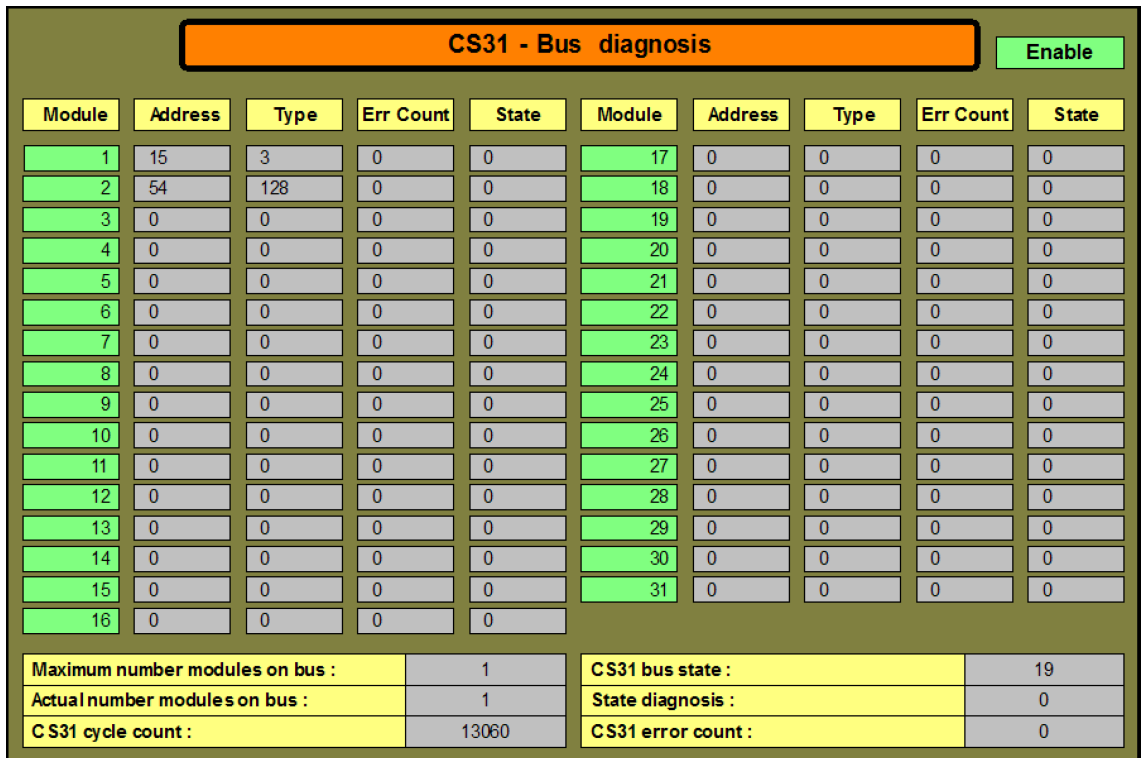

Fig. 7: Visualization: CS31 bus diagnosis

Table 8: Interpretation of variable *byStateDiag*

Bit	Value	Description
0	1	CS31 bus slave disconnected
1	2	Not used
2	4	Slave on CS31 bus bus not configured
3	8	Difference in the number of data bytes between configuration and CS31 bus
4	16	Internal device error
5	32	Channel error
6	64	Not used
7	128	Not used

All bits of *byStateDiag* equal 0 -> no error in CS31 bus slave.

The variables *byDiagChannel* and *byDiagErr* in the structure *strCS31_DiagOneModule* include the error channel and code. The possible values of these variables are indicated in the documentation of the respective CS31 bus slave.

Diagnosis system

The Diagnosis system of the AC500 series provides the errors in the following format:

Table 9: Error messages AC500 series

Format	e.g. name of PLC browser command diagshow all	Description
Error class	Class	1 to 4
Faulty component	Comp	11 (COM1 interface, here for the CS31 bus)
Faulty device	Dev	Address of CS31 bus slave with error
Faulty module	Mod	CS31 bus type of CS31 bus slave with error (e.g. 5 for analog input/output)
Faulty channel	Ch	See existing documentation of CS31 bus slave
Error code	Err	See existing documentation of CS31 bus slave

A CS31 bus slave error is indicated by an error LED on the CS31 bus slave. The error LED remains on even after elimination of the error and is switched off only after the error has been acknowledged by the CS31 bus master.

The acknowledgment of a CS31 bus slave error can take place via the CS31 bus master by means of the function block CS31QU_EXT.

1.4 Replacement devices: CPU

For AC31 devices of the 90 series, AC31 adapters (replacement devices) are available for the exchange of the CPU.

1.4.1 Replacement device 07KT9x-AD

1.4.1.1 Introduction

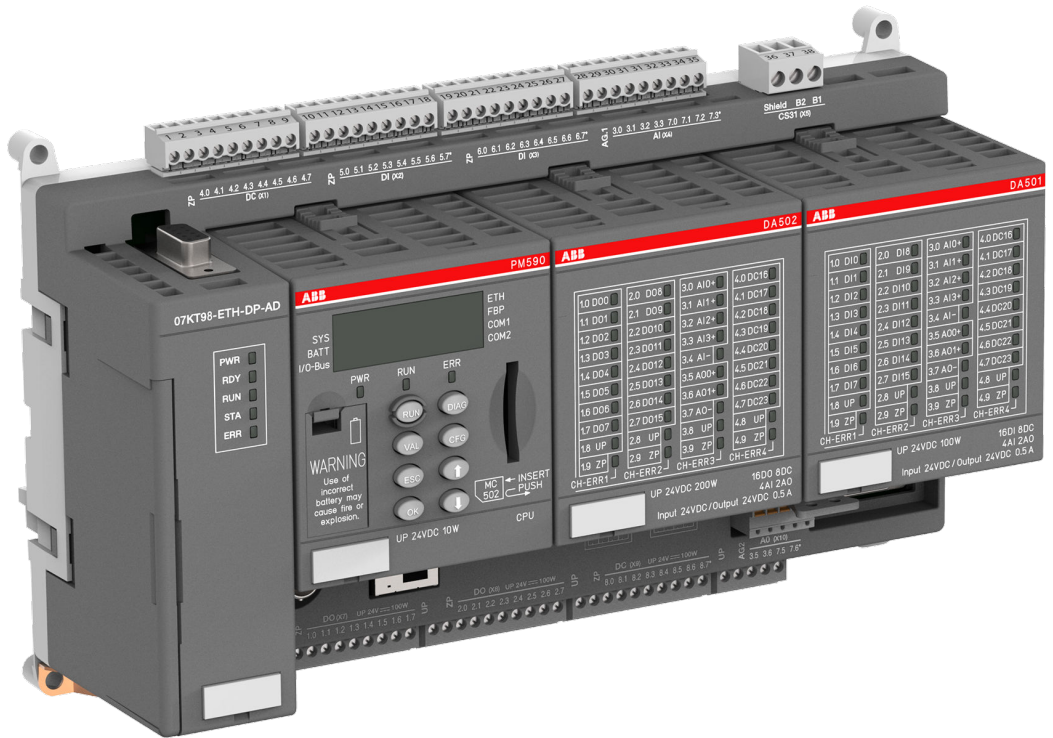

Fig. 8: 3ADR331183S0015

The replacement device versions 07KT9x-AD of the AC31 adapter series replace the existing devices 07KT94 and 07KT98 of the AC31 devices of the 90 series.

Versions:

- 07KT94-ARC-AD: I/O module DA501, I/O module DA502, CPU EC581 *)
- 07KT98-ARC-AD: I/O module DA501, I/O module DA502, CPU PM590-ARC
- 07KT98-ARC-DP-AD: I/O module DA501, I/O module DA502, CPU PM590-ARC
- 07KT98-ARC-ETH-AD: I/O module DA501, I/O module DA502, CPU PM590-ARC-ETH
- 07KT98-ETH-DP-AD: I/O module DA501, I/O module DA502, CPU PM590-ETH
- 07KT98-ARC-ETH-DP-AD: I/O module DA501, I/O module DA502, PM590-ARC-ETH

During the development of the replacement devices, care was taken to keep the device configuration identical to the configuration of the existing device. Thus, the existing documentation of device 07KT98 remains valid and serves as reference (*system description Advant Controller 31*). The document structure of this document is based on the document structure of the existing documentation.

*) Customer specific product not for standard use

This document adds the following points to the still valid existing documentation:

- Unavoidable device deviations, e.g. due to technical limitations.
- Expansion of documentation as a result of normative requirements.
- Additional contents not described in the existing documentation.

Further information on replacement devices 07KT9x-AD can be found in the operating and assembly instructions of device 07KT9x-AD: 3ADR020082M0401.

Please observe the system data for CS31 bus ↗ *Chapter 1.3 “System data and CS31 bus system data” on page 4.*

For general information on the CPU, please refer to the AC500 documentation .



In addition to the CPU, the replacement devices 07KT9x-AD are based on the modules DA501 and DA502 of the AC500 series. All I/O channels are protected against reverse polarity, reverse supply, short circuit and continuous overvoltages up to 30 V DC. For further information on these modules, please refer to the AC500 documentation.



The description of the protective functions, error indications and diagnosis options contained in the existing documentation are no longer valid. Please refer to the AC500 documentation (DA501-/ DA502 modules and CPU) concerning this information.

1.4.1.2 Central unit 07KT98

1.4.1.2.1 Short description

The central unit 07KT9x-AD acts as

- bus master in the decentralized automation system.
Slave operation is not possible.
- Advant Controller 31 or as stand-alone central unit.

Main features

- 16 digital inputs with LED display.
Caution! Galvanic isolation/potential reference has changed.
- 16 digital outputs with LED display.
Caution! Galvanic isolation/potential reference has changed.
- 16 digital inputs/outputs with LED display.
Caution! Galvanic isolation/potential reference has changed.
- 8 individually configurable analog inputs. Available modes ↗ *Chapter 1.4.1.3.1.7 “Connection of the 8 configurable analog inputs” on page 34.*
Caution! Galvanic isolation/potential reference has changed.
- 4 individually configurable analog outputs.
Caution! Galvanic isolation/potential reference has changed.
- 2 counters for counting frequencies up to 50 kHz, configurable in 10 different modes.
Caution! Each counting input requires an external resistor of 470 Ω / 1 W that is connected upstream. The potential reference has changed.
- 1 serial interface COM2
 - Modbus RTU, master and slave
 - An online access (RS-232 programming interface for PC/Automation Builder)
 - A free protocol (communication via the blocks COM_SEND and COM_REC)
- 1 serial diagnosis interface DIAG
Caution! No galvanic isolation to supply voltage L+/M.
- LED LCD display to indicate operating conditions and error messages
- Fastening by screws or snapping onto top-hat rail
- Lithium battery TA521
- Various operating buttons for user input
- Comprehensive diagnosis functions
- Integrated Flash EPROM, RAM and memory for storing programs and data
- Exchangeable memory card

Planning/ commissioning

Software Automation Builder (see AC500 documentation):

- 07KT98-ARC-AD
- 07KT98-ARC-DP-AD
- 07KT98-ARC-ETH-AD
- 07KT98-ETH-DP-AD
- 07KT98-ARC-ETH-DP-AD

Software 907PC331

- 07KT94-ARC-AD

1.4.1.2.2 Functionality

Table 10: Existing device vs. replacement device

Designation	Existing device: 07KT98	Replacement device: 07KT9x-AD	Note
User program	1 MB	CPU PM590: 2 MB storage, memory card slot	-
User data	1 MB + 256 kB RETAIN + 128 kB (Flash EPROM)	CPU PM590: 2 MB storage, memory card slot	-
Digital inputs	24 in 3 groups (8 each), galvanically isolated	16 in 2 groups (8 each). Caution: Potential reference/galvanic isolation	Potential reference/galvanic isolation has changed *).
Digital outputs	16 transistor outputs in 2 groups (8 each), galvanically isolated	16 in 2 groups (8 each). Caution: Potential reference/galvanic isolation	Potential reference/galvanic isolation has changed *).
Digital inputs/outputs	8 in 1 group, galvanically isolated	16 in 2 groups (8 each). Caution: Potential reference/galvanic isolation	Potential reference/galvanic isolation has changed *).
Analog inputs	8 in 1 group, individually configurable to 0 V ... 10 V, 0 V ... 5 V, ± 10 V, ± 5 V, 0 mA... 20 mA, 4 mA ... 20 mA, Pt100 (2-wire or 3-wire), differential inputs, digital inputs	8 in 1 group, individually configurable 0 V ... 10 V, ±10 V, 0 V ... 20 mA, 4 mA ... 20 mA, Pt100/ PT1000/ Ni1000 (2-wire or 3-wire), differential inputs, digital inputs	Potential reference has changed *). Some wiring adjustments are required in part. 5 V measuring ranges can be shown with 10 V measuring range.
Analog inputs (can also be configured as digital inputs)	Yes	Yes	Caution: AGND reference to ZP no longer M
Analog outputs	4 in 1 group, individually configurable to ± 10 V, 0 mA ... 20 mA, 4 mA ... 20 mA	4 in 1 group, individually configurable to ± 10 V, 0 mA ... 20 mA, 4 mA ... 20 mA	Caution: AGND reference to ZP no longer M *). Some wiring adjustments are required in part.

Designation	Existing device: 07KT98	Replacement device: 07KT9x-AD	Note
Serial Interfaces	COM1, COM2 as Modbus interfaces, for programming and test functions as well as freely programmable interfaces	COM2 (programming function, test function, free protocol) DIAG (diagnosis interface)	The serial COM1 interface of 07KT9x is no longer available. The serial diagnosis interface DIAG has a reduced range of functions and is not galvanically isolated from the supply voltage L+/M.
Parallel interface	For connection to communication module	For connection to communication module	Additional information upon request.
System bus interface	CS31	CS31	Caution: Terminal "Shield" is internally connected to FE (functional earth).
High-speed counter	Integrated, many functions configurable	Integrated, many configurable operating modes	At the counting input, an external resistor of 470 Ω / 1 W must always be connected upstream. For further information on high-speed counters, please refer to the AC500 documentation.
Real-time clock	Integrated	Integrated	-
Memory card	SmartMedia Card: Storage medium for operating system, user program and user data	Memory card: for the backup of user data, storage of the user program and update of the internal CPU firmware	-
Display LEDs	For signal states, operating conditions and error messages	Indication on LEDs and LCD display	-
Supply voltage	24V	24V	-
Data buffering	With lithium battery 07 LE 90	With lithium battery TA521	-
Programming software	907 AC 1131 as of V 4.1 (07KT98 with ARCNET interface) 907 AC 1131 as of V 4.3 (07KT98 with PROFIBUS DP interface)	Automation Builder as of V1.2	-
Processing time	Processing time: 65% bit, 35% word, for 1 kB program, typ. 0.07 ms	Cycle time for 1 instruction (CPU PM590). Binary: min. 0.002 μs, word: min. 0.004 μs, floating point: min. 0.004 μs	-

*) ↪ Chapter 1.4.1.3.1 “Connections” on page 26

Table 11: Comparison: Replacement device versions

	07KT94-ARC-AD	07KT98-ARC-AD	07KT98-ARC-DP-AD	07KT98-ARC-ETH-AD	07KT98-ETH-DP-AD	07KT98-ARC-ETH-DP-AD
ARCNET	x	x	x	x	-	x
PROFIBUS	-	-	x	-	x	x
Ethernet	-	-	-	x	x	x
CS31	x	x	x	x	x	x
Parallel interface for connection to communication module	-	x	x	x	x	x
Cycle time for 1 instruction	CPU EC581: n.a.	*)	*)	*)	*)	*)

*) CPU PM590: -> Binary: min. 0.002 μs, -> word: min. 0.004 μs, -> floating point: min. 0.004 μs

Available versions

To get an overview of the the available versions for 07 KT 98 central units, please refer to previous chapter ↪ Table 11 “Comparison: Replacement device versions” on page 24.

Suitable Smart-Media cards

The 07KT9x-AD systems use memory cards of the type "SD Memory Card MC502".

1.4.1.3 Device configuration

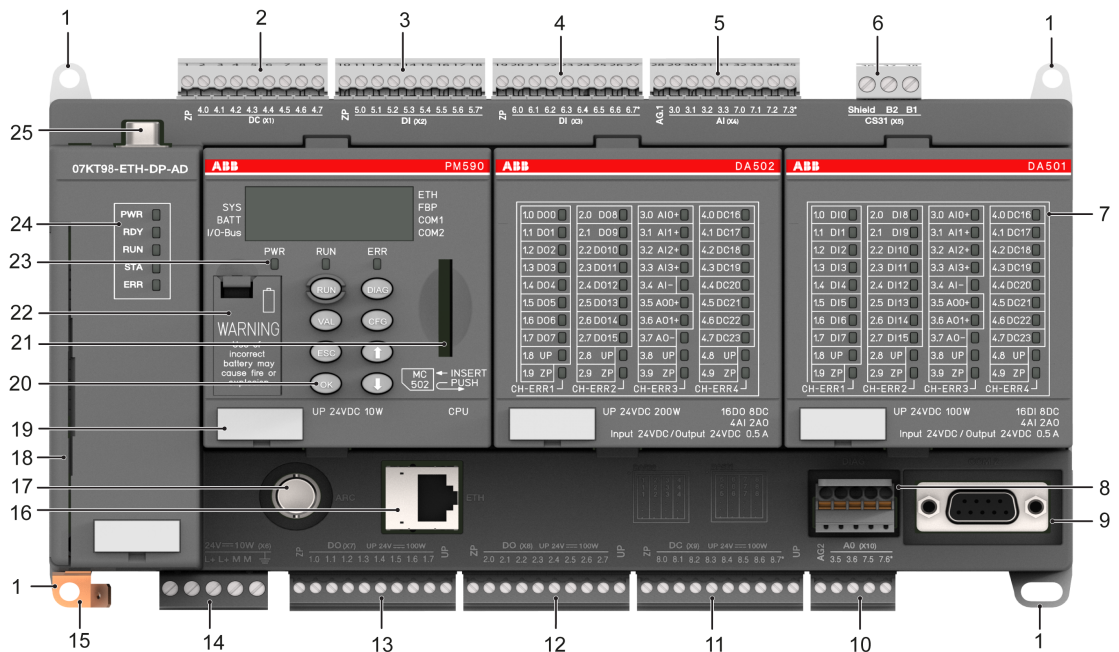

- 1 Hole for screw mounting (screw diameter 4 mm, extension torque 1.2 Nm)
- 2 Digital inputs/outputs for DA502
- 3 Digital inputs for DA501
- 4 Digital inputs for DA501
- 5 Analog inputs for DA501/DA502
- 6 CS31 bus Interface
- 7 Status LEDs for DA501/DA502
- 8 DIAG: Serial interface (diagnosis)
- 9 COM2: Serial interface (thread UNC 4-40)
- 10 Analog outputs for DA501/DA502. ± 10 V, 0 mA ... 20 mA, 4 mA ... 20 mA in one group
- 11 Digital inputs/outputs for DA501
- 12 Digital outputs for DA502
- 13 Digital outputs for DA502
- 14 Supply voltage connection 24 V DC (CPU and communication module)
- 15 Ground connection (FE). Connection for 6.3 mm Faston.
- 16 Ethernet: Network interface (function depends on device version)
- 17 Interface for ARCNET (BNC)
- 18 External network interface
- 19 TA525: Label
- 20 8 operating buttons
- 21 Memory card
- 22 Battery compartment for lithium battery TA521
- 23 3 system LEDs
- 24 5 status LEDs (only for PROFIBUS)
- 25 Connection for PROFIBUS (optional) (function depends on device version)

For information on the available I/O modules DA501 and DA502, please refer to the AC500 documentation. The CPU module used (here: PM590) depends on the model version.

1.4.1.3.1 Connections

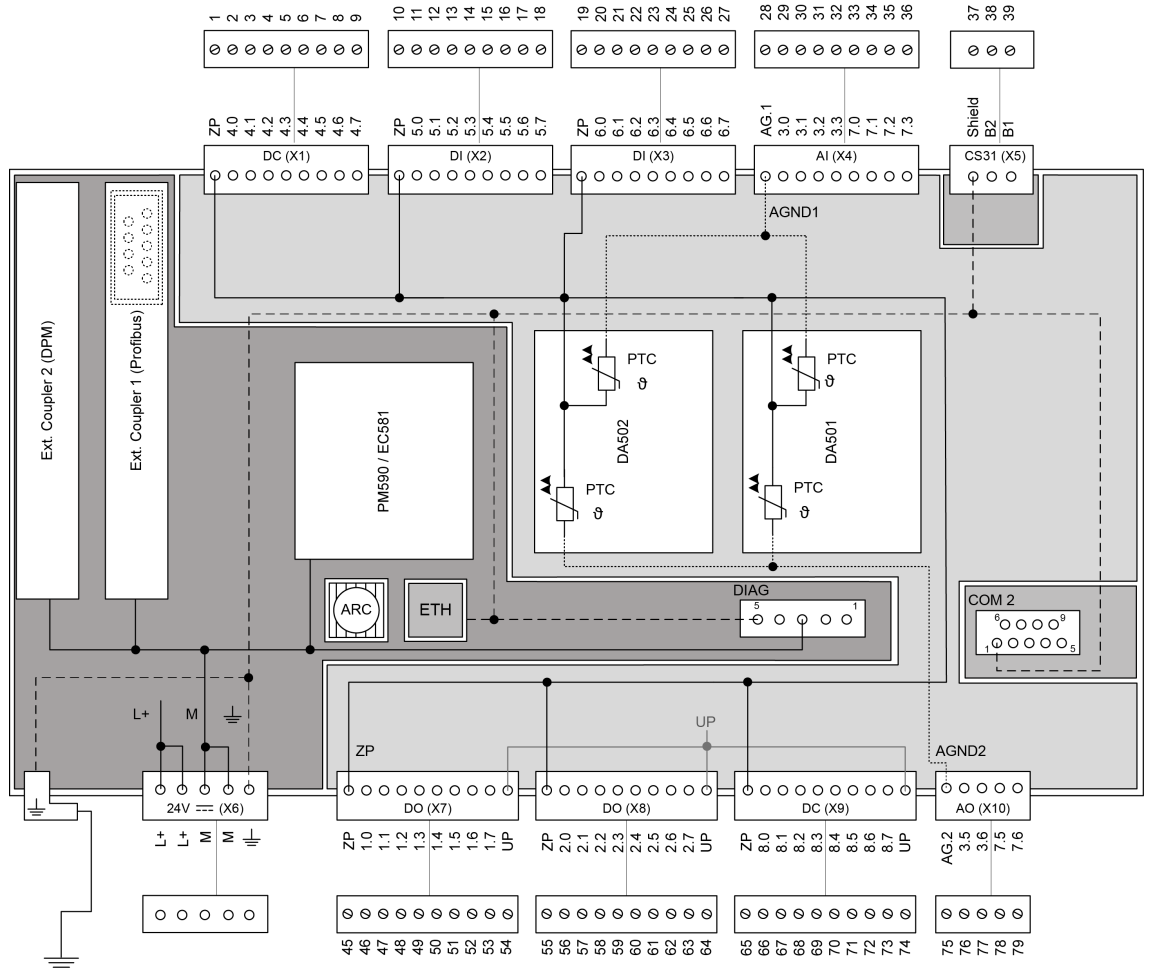

Fig. 9: Terminal assignment 07KT9x-AD

- DIAG No galvanic isolation (M)
- COM2 Galvanically isolated
- CS31 bus Galvanically isolated
- Ethernet Galvanically isolated
- ARCNET Galvanically isolated
- DA501/DA502 Galvanically isolated

Further information on grounding: ↗ Chapter 1.3.1.7 “Grounding” on page 7.

Application example for connecting the inputs and outputs

Please observe the following information: ↗ Chapter 1.3 “System data and CS31 bus system data” on page 4

Connection of the supply voltage

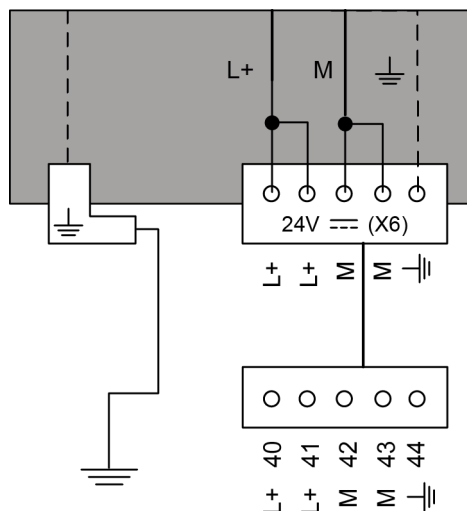

Fig. 10: Connection of the supply voltage

Table 12: Connector (X6)

Connector / Terminal	Pin	Assignment / Signal
X6 / L+	40	Supply voltage +24 V DC
X6 / L+	41	Supply voltage +24 V DC
X6 / M	42	Ground connection (0 V)
X6 / M	43	Ground connection (0 V)
X6 / functional earth	44	The functional earth (FE) is connected to the Faston terminal inside the device. Ensure that no ground loops are created and that FE and Faston are connected to the same ground potential.



NOTICE!

- In addition to connecting the supply voltage (L+/M) to X6, the supply voltage (UP/ZP) must be connected to all connectors.
- ZP must be connected to all connectors (X1, X2, X3, X7, X8, X9).
- UP must be connected to all connectors (X7, X8, X9).
- L+/M and UP/ZP must always be supplied with voltage.

Connection for CS31 bus

Table 13: Connector (X5)

Connector / Terminal	Pin	Assignment / Signal
X5 / shield	37	Shield (functional earth)
X5 / B2	38	BUS2
X5 / B1	39	BUS1



Terminal "Shield" is internally connected to FE. The previous grounding measures, e.g. with clip at the switchgear cabinet, are still required. ↪ Chapter 1.3 "System data and CS31 bus system data" on page 4

If 07KT9x-AD is connected to one of the bus ends, a 120 Ω resistor must be connected for bus termination. The device 07KT9x-AD always functions as master. Slave operation is not possible. Further information on CS31 bus: ↪ Chapter 1.3 "System data and CS31 bus system data" on page 4

Connection of digital inputs

See ↪ Chapter 1.4.1.3.1 "Connections" on page 26 .

Table 14: Connector X2

Connector / Terminal	Pin	Assignment / Signal
X2 / ZP	10	ZP
X2 / 5.0	11	DA501 / DI0
X2 / 5.1	12	DA501 / DI1
X2 / 5.2	13	DA501 / DI2
X2 / 5.3	14	DA501 / DI3
X2 / 5.4	15	DA501 / DI4
X2 / 5.5	16	DA501 / DI5
X2 / 5.6	17	DA501 / DI6
X2 / 5.7	18	DA501 / DI7

Table 15: Connector (X3)

Connector / Terminal	Pin	Assignment / Signal
X3 / ZP	19	ZP
X3 / 6.0	20	DA501 / DI8
X3 / 6.1	21	DA501 / DI9
X3 / 6.2	22	DA501 / DI10
X3 / 6.3	23	DA501 / DI11
X3 / 6.4	24	DA501 / DI12
X3 / 6.5	25	DA501 / DI13
X3 / 6.6	26	DA501 / DI14
X3 / 6.7	27	DA501 / DI15

In contrast to the existing device 07KT98, the function of the digital inputs is only possible if voltage UP is connected.

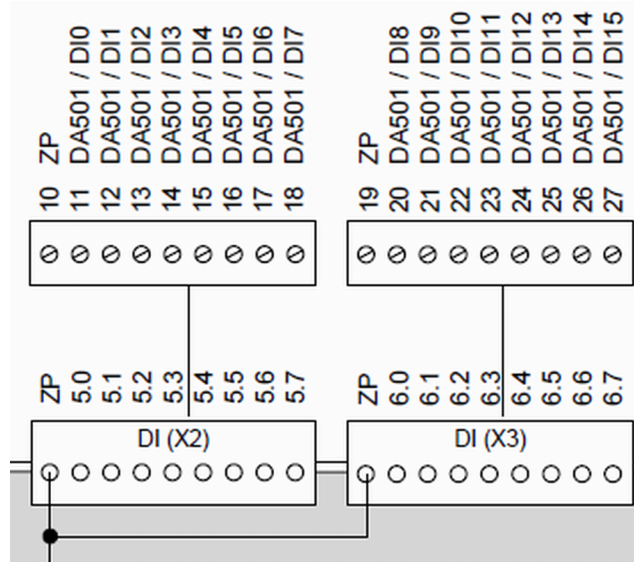

Fig. 11: Arrangement of the 16 digital inputs

The digital input states are always indicated by the LEDs DI0 ... DI15:

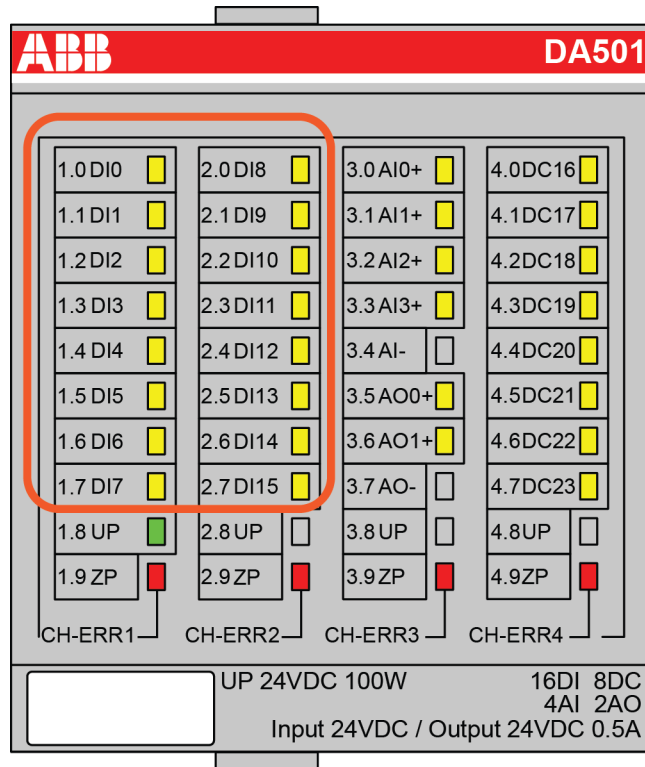

Fig. 12: DA501 LED status indication

Characteristics of the digital inputs:

- All 16 inputs have the same potential ZP as all other inputs/outputs. The galvanic isolation included in the existing devices is no longer available.
- Input delay (0->1 or 1->0): Typically 0.1 ms, configurable from 0.1 to 32 ms.



The signal coupling of the input signals is no longer realized via optocoupler. All channels of the DA501 and DA502 modules have reference to ZP. The AGND1/AGND2 of the analog channels are internally connected to ZP via PTC resistors. For information on terminal assignment, refer to figure Fig. 9).

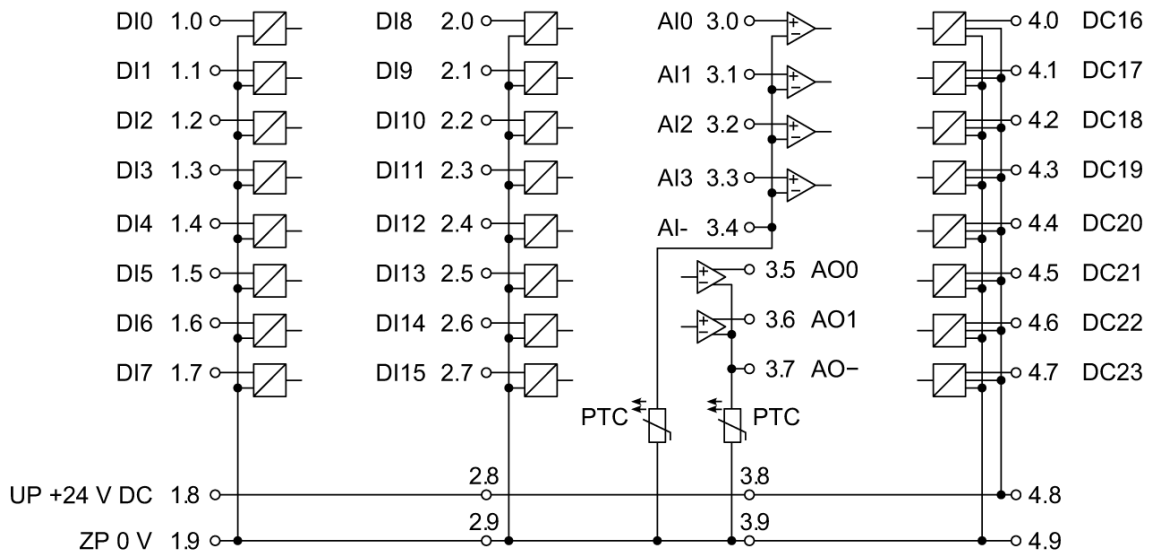

Fig. 13: Circuit arrangement of DA501 module

Connection of the digital outputs

See [Chapter 1.4.1.3.1 "Connections"](#) on page 26.

Table 16: Connector (X7)

Connector / Terminal	Pin	Assignment / Signal
X7 / ZP	45	ZP
X7 / 1.0	46	DA502 / DO0
X7 / 1.1	47	DA502 / DO1
X7 / 1.2	48	DA502 / DO2
X7 / 1.3	49	DA502 / DO3
X7 / 1.4	50	DA502 / DO4
X7 / 1.5	51	DA502 / DO5
X7 / 1.6	52	DA502 / DO6
X7 / 1.7	53	DA502 / DO7
X7 / UP	54	UP

Table 17: Connector (X8)

Connector / Terminal	Pin	Assignment / Signal
X8 / ZP	55	ZP
X8 / 2.0	56	DA502 / DO8
X8 / 2.1	57	DA502 / DO9
X8 / 2.2	58	DA502 / DO10
X8 / 2.3	59	DA502 / DO11
X8 / 2.4	60	DA502 / DO12
X8 / 2.5	61	DA502 / DO13
X8 / 2.6	62	DA502 / DO14

Connector / Terminal	Pin	Assignment / Signal
X8 / 2.7	63	DA502 / DO15
X8 / UP	64	UP

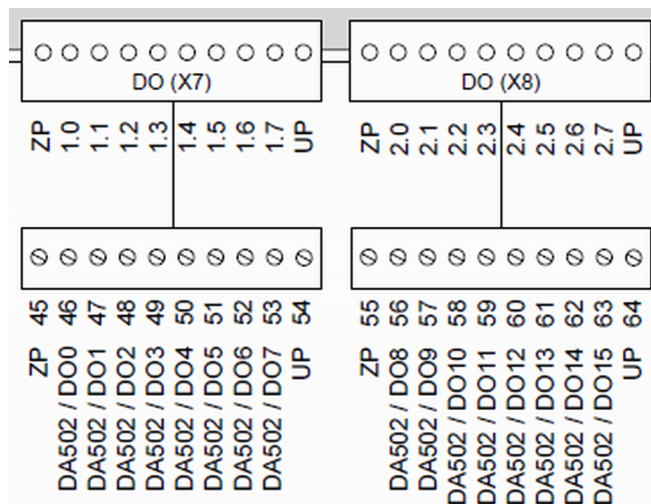

Fig. 14: Arrangement of digital outputs

Characteristics of the digital outputs

- The digital output states are always indicated by the LEDs DO0 ... DO15 on DA501 module.
- All 16 outputs have the same potential ZP as all other inputs/outputs. The galvanic isolation included in the existing devices is no longer available.
- Diagnosis: Stored errors are indicated via an LED and can be accessed by the CPU (see AC500 documentation).

Circuit arrangement of digital outputs

- Fig. 14
- ↪ *Further information on page 33*

Connection of the digital inputs/outputs

Table 18: Connector (X1)

Connector / Terminal	Pin	Assignment / Signal
X1 / ZP	1	ZP
X1 / 4.0	2	DA502 / DC16
X1 / 4.1	3	DA502 / DC17
X1 / 4.2	4	DA502 / DC18
X1 / 4.3	5	DA502 / DC19
X1 / 4.4	6	DA502 / DC20
X1 / 4.5	7	DA502 / DC21
X1 / 4.6	8	DA502 / DC22
X1 / 4.7	9	DA502 / DC23

Table 19: Connector (X9)

Connector / Terminal	Pin	Assignment / Signal
X9 / ZP	65	ZP
X9 / 8.0	66	DA501 / DC16
X9 / 8.1	67	DA501 / DC17
X9 / 8.2	68	DA501 / DC18
X9 / 8.3	69	DA501 / DC19
X9 / 8.4	70	DA501 / DC20
X9 / 8.5	71	DA501 / DC21
X9 / 8.6	72	DA501 / DC22
X9 / 8.7	73	DA501 / DC23
X9 / UP	74	UP

The arrangement of the 16 digital inputs/outputs is shown below:

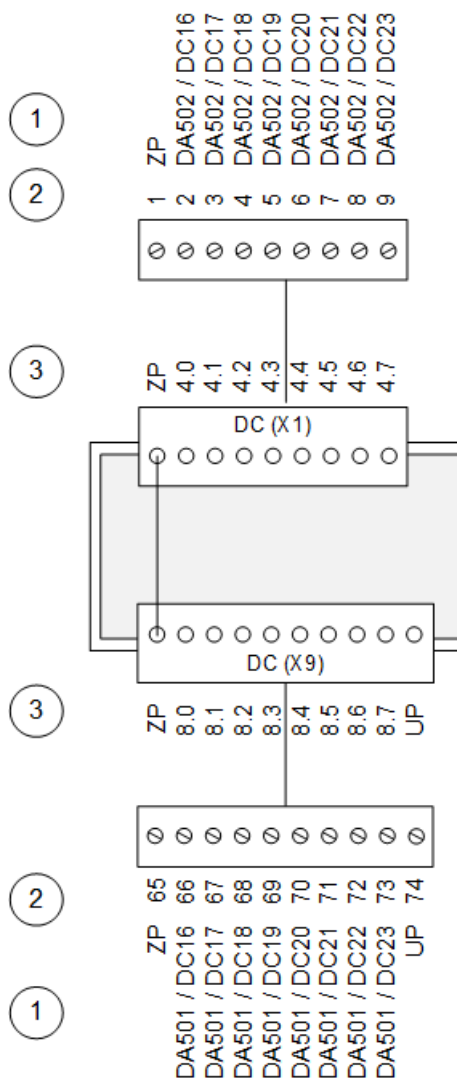

Fig. 15: Digital inputs/outputs

- 1 Module assignment
- 2 Terminal number
- 3 Terminal

Characteristics of the digital inputs/outputs

- The digital input/output states are always indicated via the LEDs DC16 - DC23 on DA501 or DA502.
- All 16 inputs/outputs have the same potential ZP as all other inputs/outputs. The galvanic isolation included in the existing devices is no longer available.
- Diagnosis: Stored errors are indicated via an LED and can be accessed by the CPU (see AC500 documentation).
- The inputs/outputs can be configured as input and as output. The outputs can also be read back.
- Input delay (0->1 or 1->0): Typically 0.1 ms, configurable 0.1 ms ... 32 ms.
- The total current consumption of all 16 DC channels must not exceed 4 A.
- The total current consumption of all 16 DO and 16 DC channels must not exceed 12 A.

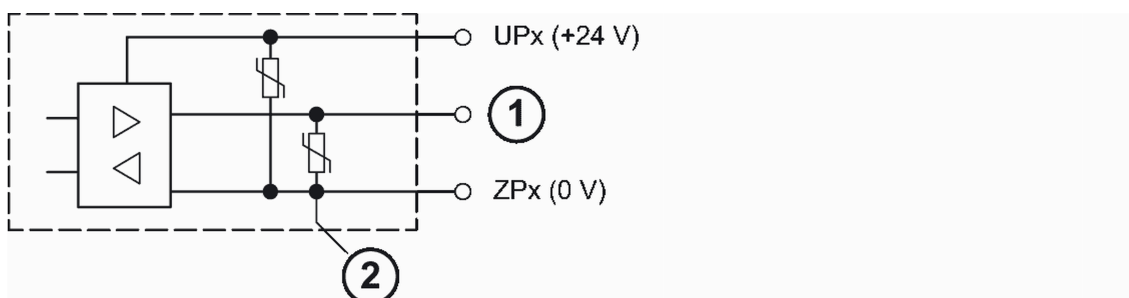



Fig. 16: Circuitry of a digital input/output with varistors for demagnetization when switching off inductive loads

- 1 Digital input/output
- 2 For demagnetization when switching off inductive loads

Data	Value
Input signal voltage	24 V DC
0 signal	-3 V ... +5 V
Undefined signal state	> +5 V ... < +15 V
1 signal	+15 V ... +30 V

 *The technical input data contained in the existing documentation are no longer valid.*

The varistor protection circuit has changed. The varistors for demagnetization are no longer located between UP and the respective channel, but rather between ZP and the respective channel. It is no longer possible to connect the voltage supply UP to connector X5 and thus use the input voltage range from -30 V ... 30 V. At the inputs, only voltages -3 V ... +30 V may be applied. UP must always be connected to all connectors (X7, X8, X9).

Connection of the 8 configurable analog inputs

Table 20: Connector (X4)

Connector / Terminal	Pin	Assignment / Signal
X4 / AG.1	28	AGND1
X4 / 3.0	29	DA502 / AI0+
X4 / 3.1	30	DA502 / AI1+
X4 / 3.2	31	DA502 / AI2+
X4 / 3.3	32	DA502 / AI3+
X4 / 7.0	33	DA501 / AI0+
X4 / 7.1	34	DA501 / AI1+
X4 / 7.2	35	DA501 / AI2+
X4 / 7.3	36	DA501 / AI3+

To be able to use the analog inputs, UP must be connected. L+/M and UP/ZP must always be supplied with voltage.

To be able to use the analog inputs, UP must be connected. L+/M and UP/ZP must always be supplied with voltage.

The analog channels offer self-protective functions and diagnosis options in the following situations:

- Above range of analog value (input)
- Above range of analog value (output)
- Below range of analog value (input)
- Below range of analog value (output)
- Wire breakage
- Short circuit

For further information on behavior and indication of these errors, please refer to the AC500 documentation. The arrangement of the 8 analog inputs is shown below on X4.

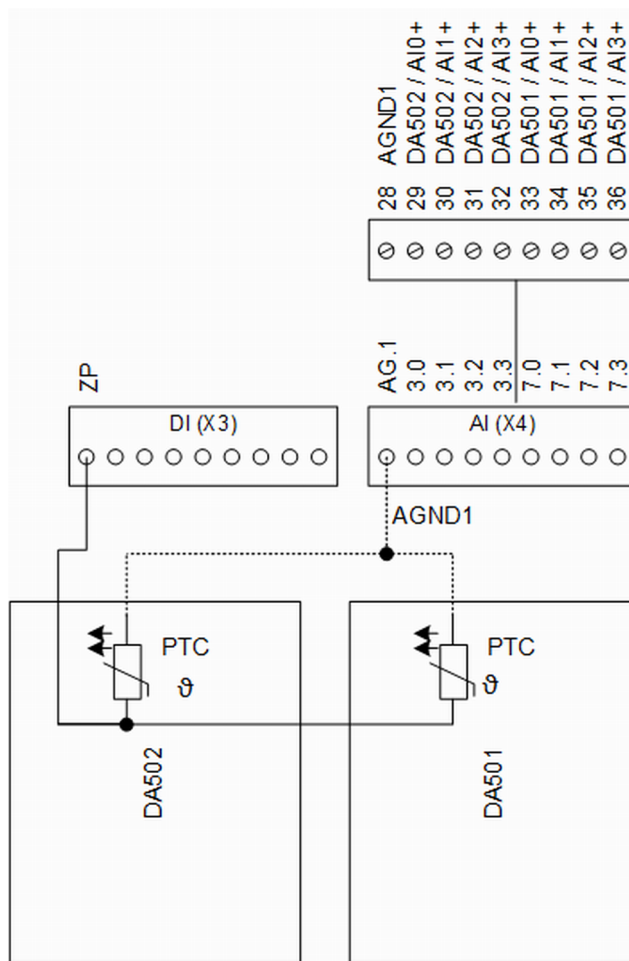



Fig. 17: Arrangement of the analog inputs

 Reference to earth ZP: connect ZP to several connectors. In the example, ZP is connected to connector X3.

Characteristics of the analog inputs:

- The 8 analog inputs are not galvanically isolated. The internal PTC connection is connected to ground ZP (existing device: earth M). Depending on sensor type or measuring principle, this may result in wiring adjustments.
- Resolution:
 - Range 0 V ... 10 V: 12 bit
 - Range -10 V ... +10 V: 12 bit + sign
 - Range 0 mA ... 20 mA: 12 bit
 - Range 4 mA ... 20 mA: 12 bit
 - Range RTD (Pt100, PT1000, Ni1000): 0.1 °C

Connection examples for analog transmitters are shown below.

Measuring ranges 07KT98

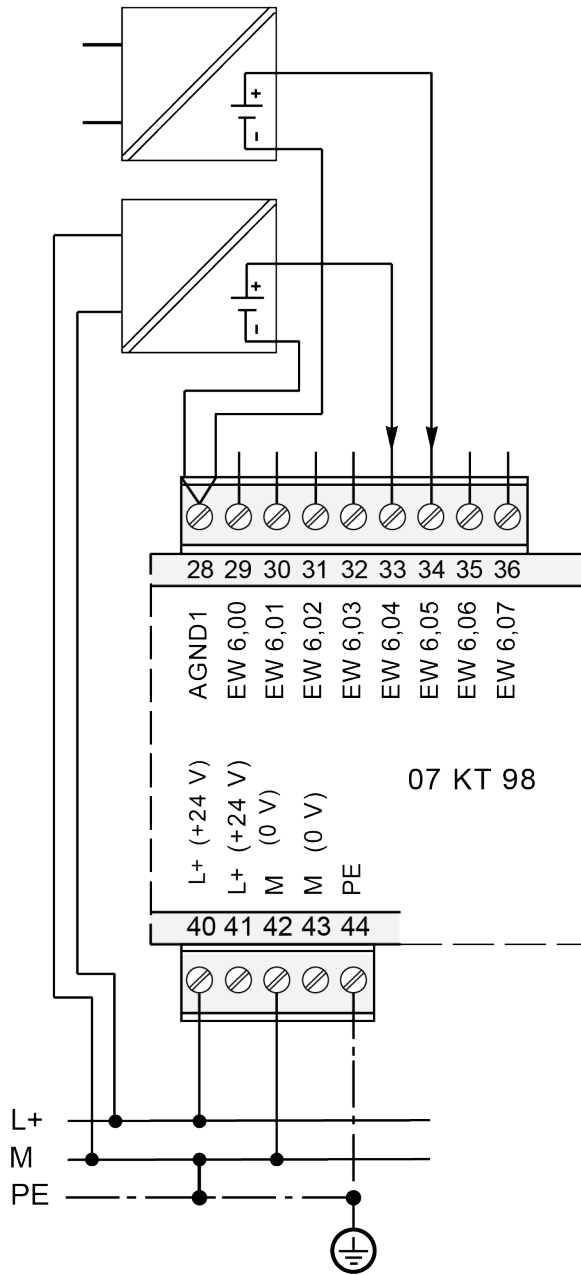



Fig. 18: Measuring ranges $\pm 10\text{ V} / 0 \dots 10\text{ V}$

Due to the internal galvanic isolation of the sensor voltage supply, no change to the wiring is necessary.

 *UP must be connected to connectors X7, X8 and X9. The internal voltage supply to the ADC channels is no longer provided by L+ but by UP in the modules DA501 and DA502.*

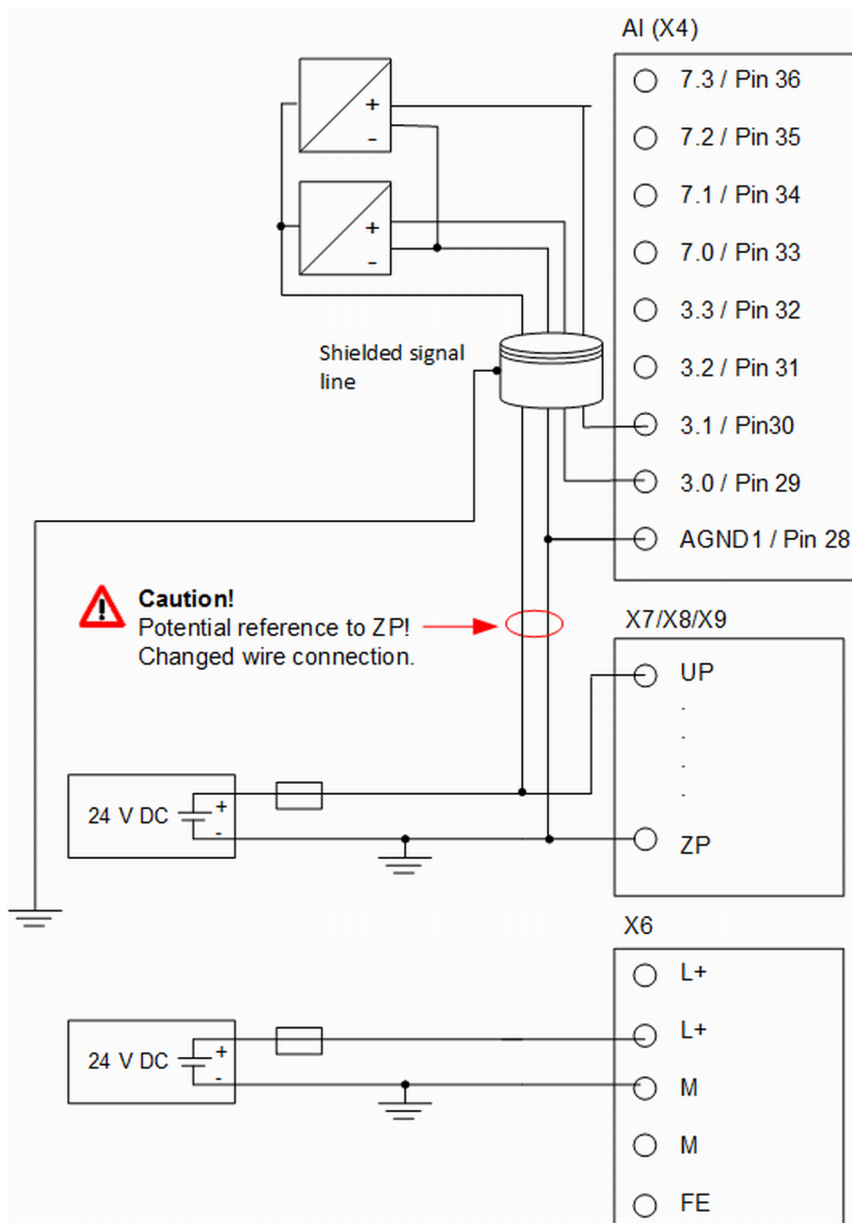

Fig. 19: Voltage input with externally supplied 3-wire voltage sensors

Measuring ranges (passive two pole sensors)

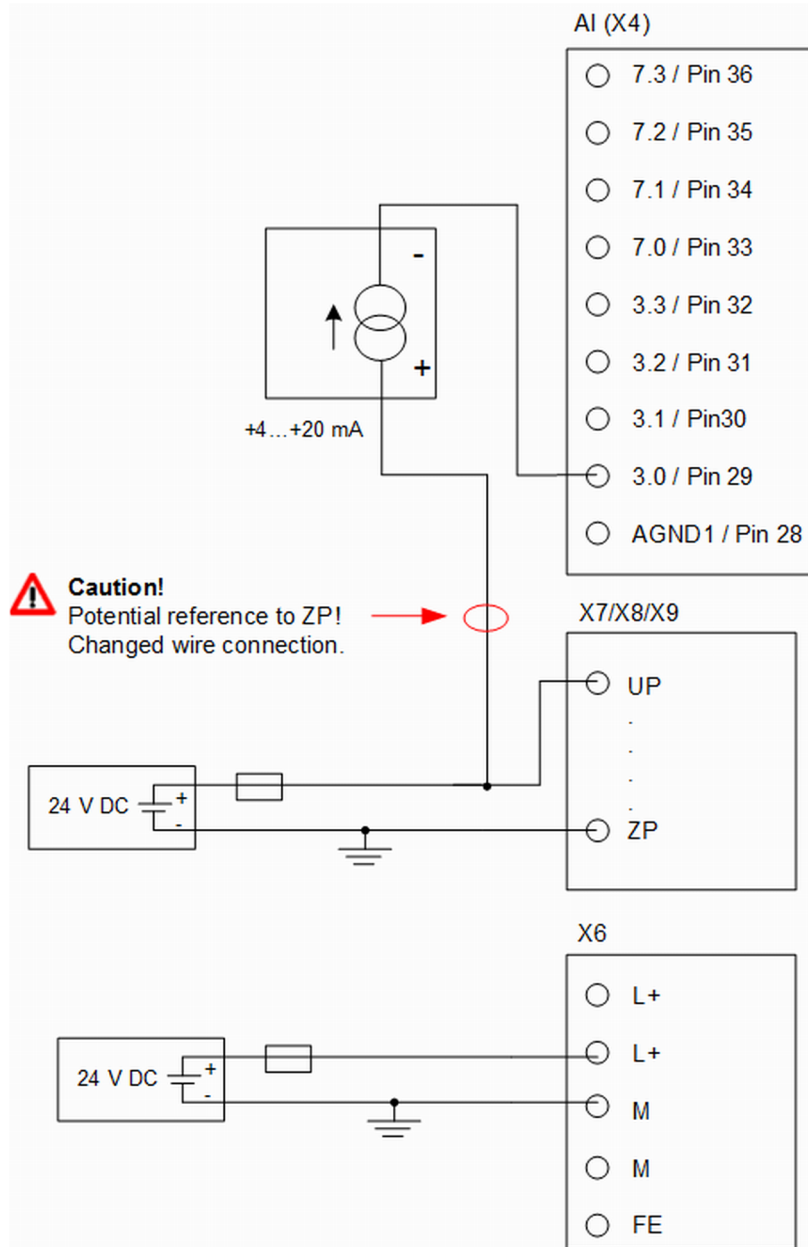



Fig. 20: Connection of current sensors 4 ... 20 mA to the analog inputs

 If the analog current sensors 4 mA ... 20 mA are supplied from a separate power supply unit, the 0 V/GND connection of the power supply unit must be connected to the ZP connection of the 07KT9x-AD.

Protective functions

 **CAUTION!**
Risk of overloading the analog input!
 If an analog current sensor supplies a current in excess of 25 mA for more than 1 second during initialization, this input is switched off by the module (input protection).
 Use only sensors with fast initialization or sensors without current peaks higher than 25 mA. If this is not possible, protect the input by connecting a 10-volt zener diode in parallel to I+ and I-.

For further information on protective function, error indication and diagnosis, please refer to the AC500 documentation.

Measuring range (active sensors with external supply)

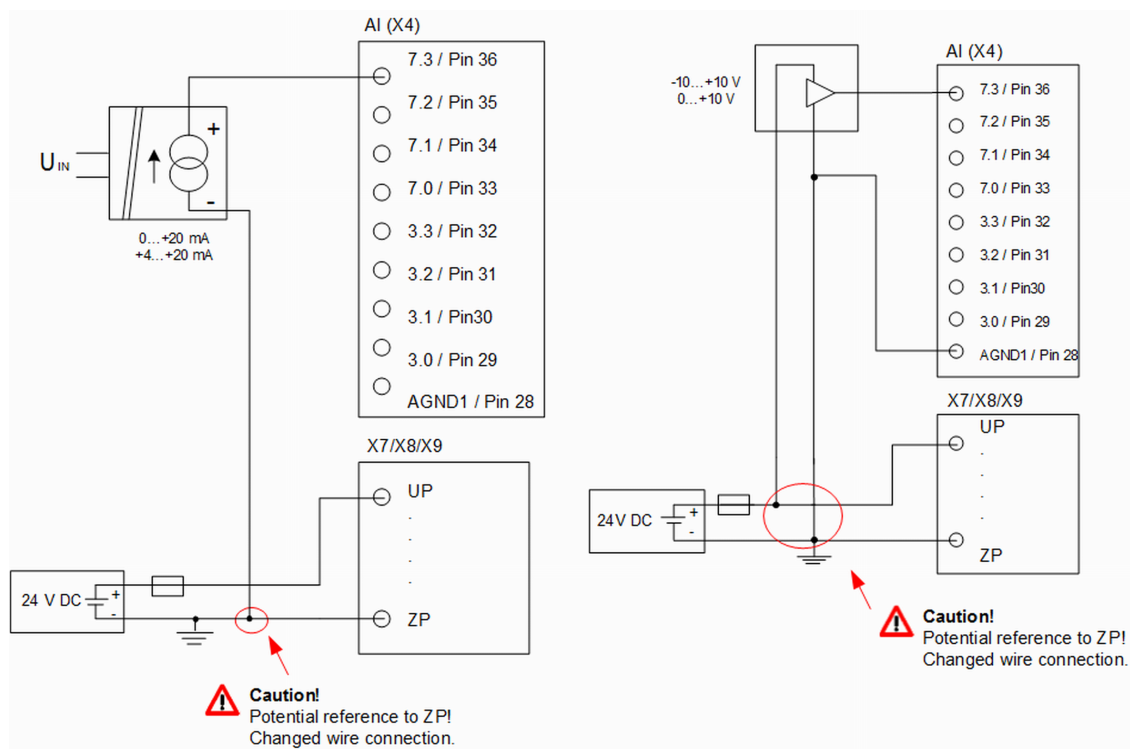

Fig. 21: Connection of current sensors 0 mA ... 20 mA to the analog inputs

Please note that in the example the 0 V supply (ZP) must be used as reference potential.

For further information on protective functions, error indication and diagnosis, please refer to the AC500 documentation.

Measuring ranges ± 10 V / 0 ... 10 V as differential inputs

Differential inputs are very useful when applying analog sensors with non-isolated installation at the site (e.g. if the minus terminal is grounded on site). The measurement via differential inputs considerably improves the measuring accuracy and prevents ground loops.

When configuring differential inputs, always two adjacent analog channels belong together (e.g. the channels 3.0 and 3.1). In this case, both channels are configured according to the desired operating mode. The channel with the lower channel number must be the one with the even number (e.g. channel 3.0).

The converted analog value is available at the odd channel (e.g. channel 3.1) and can be determined by means of the Automation Builder. The analog value is calculated by subtracting the input values: input value at the channel with the higher channel number minus input value on channel with lower channel number.

CAUTION!
Risk of faulty measurements!

The negative pole at the sensors must not have too much potential difference with respect to ZP (max. ± 1 V within the full signal range).

- Ensure that the potential difference never exceeds ± 1 V.
- No change to the wiring is necessary. The connection of the sensor corresponds to the one of the existing device 07KT98.

For further information on protective function, error indication and diagnosis, please refer to the AC500 documentation.

Measuring range with Pt100 2-wire

Table 21: Figure range

Range	Assigned figure range
-50 C ... 400°C	-500 ... +4000
-50 C ... 70°C	-500 ... +700

The following measuring ranges can be configured:

Table 22: Measuring ranges

Pt100	-50 °C ... +400 °C	2-wire configuration, 1 channel used
Pt100	-50 °C ... +70 °C	2-wire configuration, 1 channel used
Pt1000	-50 °C ... +400 °C	2-wire configuration, 1 channel used
Ni1000	-50 °C ... +150 °C	2-wire configuration, 1 channel used

Measuring values above range, below range and wire breaks are monitored and indicated.

For further information on protective function, error indication and diagnosis, please refer to the AC500 documentation.

Measuring range with Pt100 3-wire

Table 23: Figure range

Range	Assigned figure range
-50 C ... 400°C	-500 ... +4000
-50 C ... 70°C	-500 ... +700

The following measuring ranges can be configured:

Table 24: Measuring ranges

Pt100	-50 °C ... +400 °C	3-wire configuration, 2 channels used
Pt100	-50 °C ... +70 °C	3-wire configuration, 2 channels used
Pt1000	-50 °C ... +400 °C	3-wire configuration, 2 channels used
Ni1000	-50 °C ... +150 °C	3-wire configuration, 2 channels used

Caution!
 Changed wire connection.

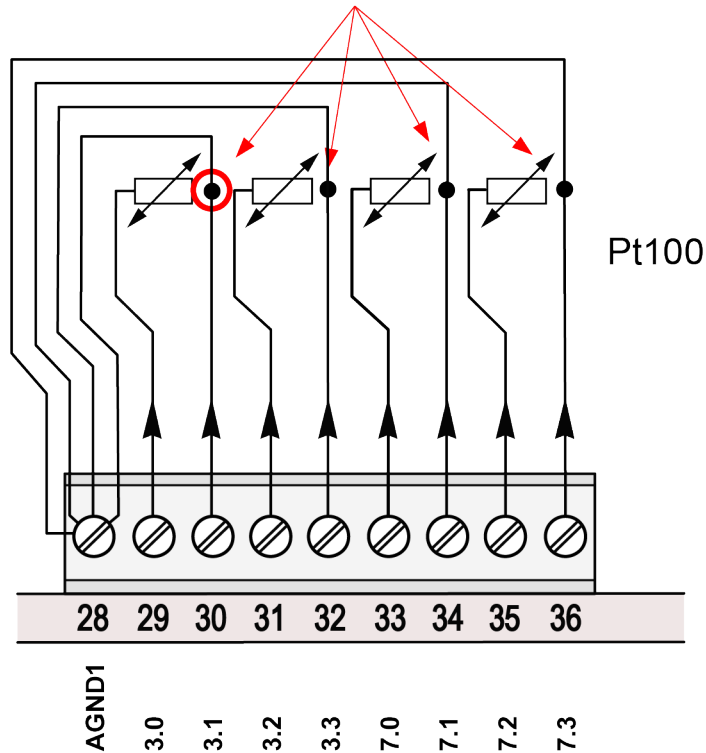

Fig. 22: Connection of Pt100 temperature sensors in 3-wire configuration

In order to keep measuring errors as small as possible, it is necessary to have all the involved conductors in the same cable. All the conductors must have the same cross section.

Measuring values above range, below range and wire breaks are monitored and indicated.

For further information on protective function, error indication and diagnosis, please refer to the AC500 documentation.

Use of analog inputs as digital inputs

Data	Value
Input signal voltage	24 V DC
<ul style="list-style-type: none"> • Signal 0 • Undefined signal state • Signal 1 	<ul style="list-style-type: none"> • -30 V ... +5 V • +5 V ... +13 V • +13 V ... +30 V
Input resistance	approx. 3.5 kΩ
Conversion cycle	1 ms (for 4 inputs + 2 outputs) 1 s when measuring with resistance thermometer Pt/Ni

ZP serves as reference signal for the inputs.

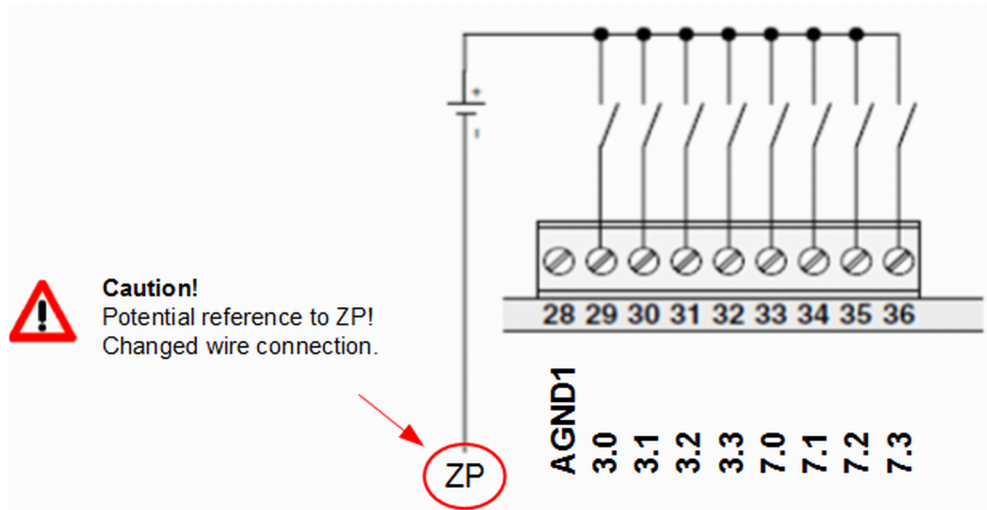

Fig. 23: Use of analog inputs as digital inputs

Connection of the 4 configurable analog outputs

Connector / Terminal	Pin	Assignment / Signal
X10 / AG.2	75	AGND2
X10 / 3.5	76	DA502 / AO0+
X10 / 3.6	77	DA502 / AO1+
X10 / 7.5	78	DA501 / AO0+
X10 / 7.6	79	DA501 / AO1+

i UP must be connected to connectors X7, X8 and X9. The internal voltage supply to the ADC channels is no longer provided by L+ but by UP in the modules DA501 and DA502.

The arrangement of the 4 analog outputs is shown below:

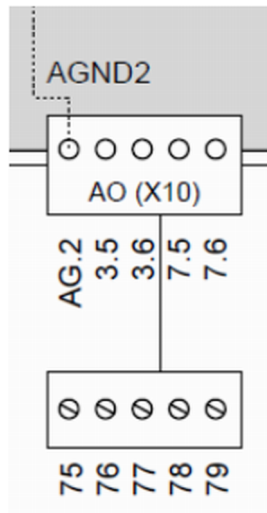

Fig. 24: Arrangement of the analog outputs

Resolution: 12 bit (+ sign)

The 4 analog outputs are not galvanically isolated and have a reference to ZP internally via PTC resistors.

Output areas
±10 V / 0 mA ...
20 mA / 4 mA ...
20 mA

No change to the wiring is necessary. The sensor is connected the same way as with the existing device 07KT98. Output load capability of voltage output: max. ± 10 mA.

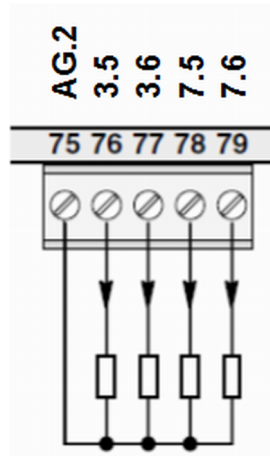

Fig. 25: Connection of output loads (voltage and current) to analog outputs

Battery and battery replacement

The AC31 adapters use another battery (lithium battery TA521).

For further information, please refer to the AC500 documentation.

Serial interface COM1

The serial interface COM1 is no longer available.

Programming can be performed via the serial interface COM2.

Serial interface DIAG

The serial interface DIAG is used for diagnosis and configuration. The DIAG interface is not galvanically isolated and thus only intended for connection with the Automation Builder.

In the CPU or Automation Builder, the DIAG interface is accessed via the neutral FBP interface. Consequently, the information of the DIAG interface appears on the CPU display under the neutral FBP interface.

Connector / Pin	Assignment / Signal
DIAG / 1	Not connected
DIAG / 2	TX
DIAG / 3	M
DIAG / 4	RX
DIAG / 5	FE

Serial interface COM2

Connector / Pin	Assignment / Signal
COM2 / 1	FE
COM2 / 2	TX
COM2 / 3	RX
COM2 / 4	RTS
COM2 / 5	CTS
COM2 / 6	Not connected
COM2 / 7	Signal Ground
COM2 / 8	Signal Ground
COM2 / 9	+5 V

The assignment of the serial interface COM2 has not changed.

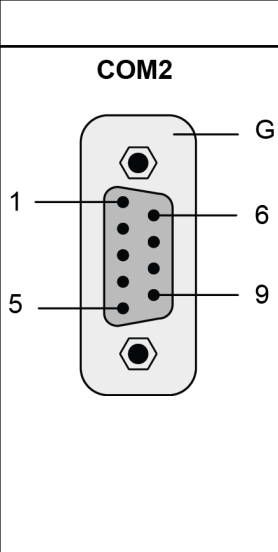
	PIN	Signal	Description
 <p>The diagram shows a 9-pin D-sub connector labeled COM2. Pin 1 is the top shield pin. Pin 2 is the top signal pin. Pin 3 is the second signal pin. Pin 4 is the third signal pin. Pin 5 is the fourth signal pin. Pin 6 is the fifth signal pin. Pin 7 is the sixth signal pin. Pin 8 is the seventh signal pin. Pin 9 is the bottom signal pin. There are two ground pins (G) at the top and bottom of the connector.</p>	G	Housing	FE
	1	FE	FE (shield)
	2	TxD	Transmit data (output)
	3	RxD	Receive data (input)
	4	RTS	Request to send (output)
	5	CTS	Clear to send (input)
	6	NC	-
	7	SGND	Signal ground (SGND)
	8	0 V out	-
9	+5 V out	Reserved	

Network interface

The existing device 07KT9x-AD has a parallel interface for connection to the communication module. Additional information upon request.

1.4.1.3.2 SmartMedia Card 07 MC 90

The content of this chapter is invalid. Another memory card is used in the CPU (Memory card MC502).

For further information on the memory card, please refer to the AC500 documentation.

1.4.1.3.3 High-speed counter

DA502

The standard fast counter input in 07KT9x-AD devices is located on connector X1 terminal X1/4.0/4.1 (DA502 /DC16/DC17). When using the counter inputs (X1/ 4.0/4.1), an external resistor 470 Ω / 1 W must be connected upstream. There are 10 operating modes available. The fast counter output is located on connector X1 terminal X1/4.2 (DA502 /DC18).

See also connection of the digital inputs/outputs ↪ *Table 18 “Connector (X1)” on page 31, Technical Data*, ↪ *Table 25 “Data of the high-speed hardware counter installed (DA502)” on page 55* and connection ↪ *Table 25 “Data of the high-speed hardware counter installed (DA502)” on page 55*.

DA501

From configuration point of view that is not forbidden to use also the fast counter coming from DA501 connector X9 terminal X9/8.0/8.1/8.2 (DA501 /DC16/DC17/DC18). When using the counter inputs (X9/ 8.0/8.1), an external resistor 470 Ω / 1 W must be connected upstream. There are 10 operating modes available. The fast counter output is located on connector X9 terminal X9/8.2 (DA501 /DC18).

See also connection of the digital inputs/outputs ↪ *Table 18 “Connector (X1)” on page 31, Technical Data*, ↪ *Table 26 “Data of the high-speed hardware counter installed (DA501)” on page 55* and connection, ↪ *Table 26 “Data of the high-speed hardware counter installed (DA501)” on page 55*.

For further information on high-speed counters, please refer to the AC500 documentation.

1.4.1.3.4 Technical data 07KT9x-AD

The technical data described in the existing documentation (chapter 2.2.7) are invalid for the AC31 adapter and are replaced by the following data.

Further information: ↪ *Chapter 1.3 “System data and CS31 bus system data” on page 4*

General data

Data	Value
Number of digital inputs	16
Number of digital outputs	16
Number of digital inputs/outputs	16
Number of analog inputs	8
Number of analog outputs	4
Supply voltages:	
-> UP	-> X7 / UP (pin 54), X7 / ZP (pin 45) -> X8 / UP (pin 64), X8 / ZP (pin 55) -> X9 / UP (pin 74), X9 / ZP (pin 65) See Fig. 9
-> Fuse for UP	16 A
-> Power consumption for UP	300 W (per 100W on X7, X8 and X9)
-> L+	X6 / L+ (pin 40), X6 / L+ (pin 41) X6 / M (pin 42), X6 / M (pin 43) See Fig. 9
-> Fuse for L+	10 A

Data	Value
-> Power consumption for L+	10 A
-> Galvanic isolation between UP and L+	Yes
Number of serial interfaces	1 COM2 (for diagnosis and programming with the Automation Builder software)
Number of serial interfaces (diagnosis)	1 DIAG (for diagnosis with the Automation Builder software)
Number of parallel interfaces	1 special interface for connection of an external communication module
Ethernet	10/100 base-TX, 1x RJ45 socket
Program memory	PM590 2MB
Resolution of the integrated real-time clock	1 s
Data of the high-speed hardware counter installed:	
-> Number of operating modes	-> 10
-> Counting range	-> 0 ... 4,294,967,295 (double word format, 32 bit)
-> Counting frequency	-> Depending on operating mode Note: At the counting input, an external resistor of 470 Ω / 1 W must always be connected upstream.
Cycle time for 1 instruction	Binary: min. 0.002 μs, word: min. 0.004 μs, floating point: min. 0.004 μs
Operating and error indications	Display via LEDs and CPU display. For detailed information, please refer to the AC500 documentation.
Connection technology	Detachable screw-type terminal blocks
Supply terminals, CS31 bus	max. 1 x 2.5 mm ² or max. 2 x 1.5 mm ²
All other terminals	max. 1 x 1.5 mm ²



For further information, please refer to the existing documentation System description Advant Controller 31.

Supply of devices

Data	Value
Rated supply voltage	24 V DC
Supply voltages:	
-> UP	X7 / UP (pin 54), X7 / ZP (pin 45) X8 / UP (pin 64), X8 / ZP (pin 55) X9 / UP (pin 74), X9 / ZP (pin 65) See Fig. 9
-> Fuse for UP	10 A
-> Power consumption for UP	300 W (per 100W on X7, X8 and X9)

Data	Value
-> L+	X6 / L+ (pin 40), X6 / L+ (pin 41) X6 / M (pin 42), X6 / M (pin 43) See Fig. 9
-> Fuse for L+	10 A
-> Power consumption for L+	10 A
-> Protection against reversed voltage	Yes
-> Galvanic isolation between UP and L+	Yes



For further information, please refer to the existing documentation [System description Advant Controller 31](#).

Lithium battery

Data	Value
Battery for buffering RAM contents and real-time clock	Lithium battery TA521
Buffer time at 25 °C	Typ. 3 years

Digital inputs

Data	Value
Number of channels per device	16
Connections	Connector X2 (terminals X5.0 ... X5.7) Connector X3 (terminals X6.0 ... X6.7)
Division of channels in groups	2 groups with 8 channels (not galvanically isolated!)
Voltage supply	UP (supplies module DA501 and 502)
Common reference potential:	
-> for group 1 (8 channels)	ZP (terminals 5.0 ... 5.07)
-> for group 2 (8 channels)	ZP (terminals 6.0 ... 6.07)
Galvanic isolation:	<ul style="list-style-type: none"> Galvanic isolation from group to group is no longer available. Galvanic isolation from DA501 and DA502 (reference ZP) to the rest of the device (reference M) is available. On DA501 and DA502, all channels have the same potential ZP. Voltage supply UP/ZP. AGND1 and AGND2 of the analog channels are internally connected to ZP via PTC resistors Fig. 9.
Configurability of the inputs	Input delay configurable (0.1 ms, 1 ms, 8 ms and 32 ms). Default: 0.1 ms.

Data	Value
Channels for high-speed counters	 Chapter 1.4.1.3.4.6 "Digital inputs/outputs" on page 49 Channels for high-speed counters are implemented with the inputs/outputs (channels: 4.0 and 4.1).
Indication of the input signals	One yellow LED each per channel. The LED corresponds functionally to the input signal.
Input signal voltage:	24 V DC
-> 0 signal	-3 V ... +5 V
-> Undefined signal state	+5 V ... + 15 V
-> 1 signal	+15 V ... +30 V
Input current per channel:	
-> Input voltage = +24 V	Typ. 5.0 mA
-> Input voltage = + 5 V	> 1 mA
-> Input voltage = +13 V	> 2 mA
-> Input voltage = +30 V	< 8.0 mA
Max. cable length unshielded	600 m
Max. cable length shielded	1000 m



For further information, please refer to the existing documentation System description Advant Controller 31.

Digital outputs

Data	Value
Number of channels per device	16 high-side switches
Connections	Connector X7 (terminals 1.0 ... 1.7) Connector X8 (terminals 2.0 ... 2.7)
Division of channels in groups	2 groups with 8 channels (not galvanically isolated!)
Common voltage supply	UP (supplies module DA501 and 502)
Common reference potential ZP:	
-> for group 1	ZP (terminals 1.0 ... 1.7)
-> for group 2	ZP (terminals 2.0 ... 2.7)

Data	Value
Galvanic isolation	<ul style="list-style-type: none"> Galvanic isolation from group to group is no longer available. Galvanic isolation from DA501 and DA502 (reference ZP) to the rest of the device (reference M). On DA501 and DA502, all channels have the same potential ZP. Voltage supply UP/ZP. AGND1 and AGND2 of the analog channels are internally connected to ZP via PTC resistors Fig. 9.
Indication of the output signals	One yellow LED each per channel. The LED corresponds functionally to the output signal.
Output current:	
-> Rated value	500 mA at UP = 24 V
-> Residual current at 0 signal	< 0.5 mA
Demagnetization with inductive load	Internally via varistor
Switching frequency with inductive load	max. 0.5 Hz
Switching frequency with lamp load	max. 11 Hz at max. 5 W
Max. cable length	1000 m (shielded) 600 m (unshielded)
Short-circuit proof / overload proof	Yes
Protection against reversed voltage of process supply voltage	Yes
Resistance to feedback against 24 V signals	Yes
Total load current (all DO channels, 1.0...1.7 max. 4A and 2.0...2.7)	max. 4 A
Total load current (all DC channels, 4.0..4.7 max. 8A and 8.0...8.7)	max. 8 A
Total load current (via UP) 16 DO channels and 16 DC channels	max. 12 A (all UP terminals must be connected)



For further information, please refer to the existing documentation [System description Advant Controller 31](#).

Digital inputs/outputs

Data	Value
Number of channels per device	16 inputs/outputs
Connections	Connector X1 (terminals 4.0 ... 4.7) Connector X9 (terminals 8.0 ... 8.7)
Division of channels in groups	2 groups of 8 channels each Group 1: terminals 4.0 ... 4.7 Group 2: terminals 8.0 ... 8.7

Data	Value
Common reference potential ZP	All digital I/O channels of the DA501 and DA502 module
Common voltage supply	UP (supplies DA501 and DA502 module)
Galvanic isolation	Galvanic isolation from group to group is no longer available. Galvanic isolation from DA501 and DA502 (reference ZP) to the rest of the device (reference M). On DA501 and DA502, all digital channels have the same potential ZP. AGND1 and AGND2 of the analog channels are internally connected to ZP via PTC resistors. Fig. 9
Configurability of the inputs:	
-> Input delay	Typically 0.1 ms, configurable from 0.1 ms to 32 ms
Indication of the input/output signals	1 yellow LED per channel. The LED is ON in "High" signal state (1 signal)
Input signal voltage (when used as input)	↪ <i>Further information on page 33.</i>
-> 0 signal	-3 V ... + 5 V
-> 1 signal	+15 V ... + 30 V
Input current per channel	↪ <i>Chapter 1.4.1.3.4.4 "Digital inputs" on page 47.</i>
Output current / switching frequency / inductive loads	↪ <i>Chapter 1.4.1.3.4.5 "Digital outputs" on page 48.</i>
Total load current (all DC channels, 4.0 ... 4.7 max. 8A and 8.0 ... 8.7)	max. 8 A
Total load current (all DO channels, 1.0 ... 1.7 max. 4A and 2.0 ... 2.7)	max. 4 A
Total load current (via UP) 16 DO channels and 16 DC channels	max. 12 A (all UP terminals must be connected)
Max. cable length	↪ <i>Chapter 1.4.1.3.4.4 "Digital inputs" on page 47</i> ↪ <i>Chapter 1.4.1.3.4.5 "Digital outputs" on page 48</i>



For further information, please refer to the existing documentation [System description Advant Controller 31](#).

Analog inputs

Data	Value
Number of channels per device	8
Connections	Connector X4 (terminals 3.0 ... 3.3 and 7.0 ... 7.3)
Division of channels in groups	1 group with 8 channels (evenly distributed among the modules DA501 and DA502 internally)
Common reference potential for analog inputs (8 channels)	AGND1 (terminals 3.0 ... 3.3 and 7.0 ... 7.3) Caution: internal reference to ZP via PTC resistors Fig. 9
Galvanic isolation	No Fig. 9
Max. permissible potential difference between terminal ZP (minus the supply voltage) and terminals AGND (minus the analog inputs and outputs)	$\pm 1 \text{ V}$ Caution: The internal reference is no longer M but ZP. ↪ Chapter 1.4.1.3.1 "Connections" on page 26
Indication of the input signals	8 yellow LEDs to indicate the signal states of the analog inputs (4 LEDs per DA501 module and DA502 module)
Configurability (optional per channel) ↪ Chapter 1.4.1.3.1.2 "Connection of the supply voltage" on page 27	0 ... 10 V, $\pm 10 \text{ V}$ (also with differential signal), 0 mA ... 20 mA, 4 mA ... 20 mA Pt100 -50 °C ... +400 °C and -50 °C ... +70 °C Pt1000 -50 °C ... +400 °C (2-wire and 3-wire configuration) Digital input
Input resistance per channel:	
-> Voltage input	> 100 k Ω
-> Current input	approx. 330 k Ω
-> Digital input	approx. 3.5 k Ω
Time constant of the input filter	Voltage: 100 μs , current: 100 μs
Conversion cycle	1 ms (for 4 inputs and 2 outputs) 1 s when measuring with resistance thermometer Pt/Ni



The "Examples for the conversion cycle" from the existing documentation 07KT98 are no longer valid.

Data	Value
Resolution in bits:	
-> Ranges	$\pm 10 \text{ V}$, 0 V ... 10 V 12 bit plus sign
-> Ranges	0 mA ... 20 mA, 4 mA ... 20 mA 12 bit without sign

Data	Value
-> Range	Pt100, Pt1000, Ni1000: 0.1 °C
Resolution in mV, µA:	
-> Range	±10 V approx. 2.5 mV
-> Range	0 V ... 10 V approx. 2.5 mV
-> Range	0 mA ... 20 mA approx. 5 µA
-> Range	4 mA ... 20 mA approx. 4 µA
Relationship between input signal and hex code	-100 % ... 0 ... +100 % = 9400H ... 0000H ... 6C00H (-27648 ... 0 ... 27648 decimal)
Conversion error of the analog values due to non-linearity. Adjustment error on delivery and resolution in the nominal range	Typ. 0.5 %, max. 1 %
Use as digital input:	
-> Signal 0	-30 V ... +5 V
-> Undefined signal state	+5 V ... +13 V
-> Signal 1	+13 V ... +30 V
Max. cable length 2-core shielded and conductor cross section > 0.14 mm ²	100 m



CAUTION!

Risk of overloading the analog input!

If an analog current sensor supplies a current in excess of 25 mA for more than 1 second during initialization, this input is switched off by the module (input protection).

Use only sensors with fast initialization or sensors without current peaks higher than 25 mA. If this is not possible, protect the input by connecting a 10-volt zener diode in parallel to I+ and I-.



For further information, please refer to the existing documentation [System description Advant Controller 31](#).

Analog outputs

Data	Value
Number of channels per device	4
Connections	Connector X10 (terminals 3.5, 3.6, 7.5 and 7.6)
Reference potential	AGND2 (terminals 3.5, 3.6, 7.5 and 7.6)
Galvanic isolation	No Fig. 9

Data	Value
Max. permissible potential difference between terminal ZP (minus the supply voltage) and terminals AGND (minus the analog inputs and outputs)	± 1 V Caution: The internal reference is no longer M but ZP. Fig. 9
Indication of output signal	4 yellow LEDs to indicate the signal states of the analog outputs (2 LEDs each at DA501 and DA502)
Output signal ranges (configurable)	-10 V ... 0 V, 0 V ... +10 V 0 mA ... 20 mA 4 mA ... 20 mA
Output load capability of voltage output	max. ± 10 mA
Resolution	12 bit (+ sign)
Resolution (1 LSB), range 10 V ... 0, 0 ... +10 V	approx. 5 mV
Relationship between output signal and hex code	-100 % ... 0 ... +100 % = 9400H ... 0000H ... 6C00H (-27648 ... 0 ... 27648 decimal)
Conversion cycle	1 ms (for 4 inputs + 2 outputs) 1 s when measuring with resistance thermometer Pt/Ni
Conversion error of the analog values due to non-linearity Adjustment error on delivery and resolution in the nominal range	Typ. 0.5 %, max. 1 %
Max. cable length, 2-core shielded and conductor cross section > 0.14 mm ²	100 m



For further information, please refer to the existing documentation [System description Advant Controller 31](#).

Connection of the serial interfaces COM2

The COM1 interface is no longer available. The assignment of the COM2 interface remains the same as in the existing device. Programming in Automation Builder can be performed via the COM2 interface.

Data	Value
Interface standard	EIA RS-232
Programming	07KT94-ARC-AD: 907 PC 331 07KT98-ARC-AD: Automation Builder
Program change	07KT94-ARC-AD: 907 PC 331 07KT98-ARC-AD: Automation Builder
Man-Machine Communication	Yes, e.g. via Automation Builder

Data	Value
Galvanic isolation	Fig. 9
Potential differences	In order to avoid potential differences between the replacement device 07KT98-AD and the peripheral devices connected to COM2, these devices are supplied by the socket in the switchgear cabinet.
Terminal assignment and description of the COM2 interface	🔗 <i>Chapter 1.4.1.3.1.11 "Serial interface COM2" on page 44</i>

 *For further information, please refer to the existing documentation [System description Advant Controller 31](#).*

**Serial interface
 DIAG**

Data	Value
Programming	07KT94-ARC-AD: 907 PC 331 07KT98x-AD: Automation Builder
Program change	07KT94-ARC-AD: 907 PC 331 07KT98x-AD: Automation Builder
Galvanic isolation	No Fig. 9

Connection to the CS31 bus

When configuring the CS31 bus interface (connector X5), select the COM1 interface of CPU PM590 in Automation Builder.

The shield connection must be internally connected to FE.

Data	Value
Interface standard	EIA RS-485
Connection:	
-> as master PLC	Yes
-> as slave PLC	No
Setting of the CS31 bus module address	No, the master has no module address
Galvanic isolation	Yes Fig. 9
Terminal assignment and description of the CS31 bus interface	🔗 <i>Chapter 1.4.1.3.1.3 "Connection for CS31 bus" on page 27</i> Note that the shield connection is internally connected to FE.

LED display

Data	Value
LEDs for signaling:	
-> State of digital inputs	1 yellow LED per channel
-> State of digital outputs	1 yellow LED per channel
-> State of digital inputs/outputs	1 yellow LED per channel
-> Supply voltage available (Supply)	1 green LED
-> Battery	1 red LED (name: ERR) at the CPU
-> Program is running (RUN)	1 green LED
-> Controller-specific errors	1 red LED (name: ERR) at the CPU
-> CS31 bus	Indication on CPU display under COM1 (CS31 bus is assigned to COM1 within the CPU)
-> Overload / short circuit of digital outputs	Red LEDs on modules DA501/ DA502 and at the CPU via ERR-LED. An indication on the display is possible.

High-speed hardware counter



At the counting input, an external resistor of 470 Ω / 1 W must always be connected upstream. For further information on high-speed counters, please refer to the AC500 documentation.

Table 25: Data of the high-speed hardware counter installed (DA502)

Data	Value
Number of operating modes	10
Counting range	0 ... 4,294,967,295 (double word format, 32 bit)
Counting frequency	Depending on operating mode
Used inputs	Connector X1, terminals 4.0 and 4.1
Used outputs	Connector X1, terminal 4.2

Table 26: Data of the high-speed hardware counter installed (DA501)

Data	Value
Number of operating modes	10
Counting range	0 ... 4,294,967,295 (double word format, 32 bit)
Counting frequency	Depending on operating mode
Used inputs	Connector X9, terminals 8.0 and 8.1
Used outputs	Connector X9, terminal 8.2

Mechanical data

Data	Value
Width x height x depth	Replacement device: 239.5 x 138 x approx. 80.9 mm Existing device: 240 x 140 x 85 mm
Weight	Replacement device 07KT94-ARCNET: 910 g Replacement device 07KT98-ARCNET: 945 g Existing device: 1.6 kg
Dimensions for mounting	See operating and assembly instructions of the replacement device (3ADR020082M0401)

Ordering data

Order No.	Scope of delivery
1SAP 801 000 R0061	CPU: 07KT94-ARC-AD
1SAP 801 400 R0060	CPU: 07KT98-ARC-AD
1SAP 801 100 R0062	CPU: 07KT98-ARC-DP-AD
1SAP 801 200 R0067	CPU: 07KT98-ARC-ETH-AD
1SAP 801 300 R0072	CPU: 07KT98-ETH-DP-AD
1SAP 801 500 R0062	CPU: 07KT98-ARC-ETH-DP-AD

1.4.1.3.5 ARCNET communication module

Central units with integrated ARCNET communication module (Attached Resource Computer Network):

- 07KT94-ARC-AD
- 07KT98-ARC-AD
- 07KT98-ARC-DP-AD
- 07KT98-ARC-ETH-AD
- 07KT98-ARC-ETH-DP-AD

Technical data

In the replacement device, addresses cannot be set via DIP switch. Instead, the ARCNET interface is configured in the Automation Builder. The ARCNET address can also optionally be set via the display.

Data	Value
Connector	ARC (BNC connector)
ARCNET interface	For coaxial cable connection

Data	Value
Recommended system cable	Cable RG 62 A/U (characteristic impedance 93 Ω) Cable length 300 m in case of ARCNET bus with 8 stations. For further information, please refer to the AC500 documentation (chapter ARCNET).
Signaling	Indication on CPU display
Galvanic isolation	Yes Fig. 9

ARCNET short description

The ARCNET interface is configured in the Automation Builder. For further information on the ARCNET interface for the respective CPU, please refer to the AC500 documentation.

ARCNET system

The general information about the ARCNET system is still valid. For further information on ARCNET, please refer to the AC500 documentation.

1.4.1.3.6 PROFIBUS DP communication module

Central units with an integrated PROFIBUS communication module:

- 07KT98-ARC-DP-AD
- 07KT98-ETH-DP-AD
- 07KT98-ARC-ETH-DP-AD

Technical data

Data	Value
Connector	9 pin D-sub socket
PROFIBUS interface	EIA RS-485 according to EN 50170
Recommended system cable	Dual twisted, shielded pair cable (characteristic impedance 135 Ω ... 165 Ω) Max. line length 1000 m with a transmission rate of 187.5 Kbps For further information, please refer to the AC500 documentation (chapter PROFIBUS).
Signaling	With 5 LEDs
Galvanic isolation	Yes Fig. 9

PROFIBUS short description

The PROFIBUS interface is configured in the Automation Builder. For further information on the PROFIBUS interface for the respective CPU used, please refer to the AC500 documentation.

The PROFIBUS system

The general information about the PROFIBUS system is still valid. For further information on PROFIBUS, please refer to the AC500 documentation.

Pin Assignment

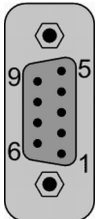
	Pin	Signal	Description
	1	NC	Not connected
	2	NC	Not connected
	3	RxD/TxD-P	Receive/Transmit positive
	4	CNTR-P	Control signal for repeater, positive
	5	DGND	Reference potential for data exchange and +5 V
	6	VP	+5 V (power supply for the bus terminating resistors)
	7	NC	Not connected
	8	RxD/TxD-N	Receive/Transmit negative
	9	NC	Not connected



In corrosive environment, please protect unused connectors using the TA535 accessory.

Not supplied with this device.

1.4.1.3.7 Ethernet communication module

Central units with an integrated Ethernet communication module:

- 07KT98-ARC-ETH-AD
- 07KT98-ETH-DP-AD
- 07KT98-ARC-ETH-DP-AD

Technical data

Data	Value
Connector	RJ45 socket
Ethernet interface	10/100 Base-TX
Recommended system cable	For detailed information, please refer to the AC500 documentation (Ethernet chapter).
Signaling	Indication on the CPU display
Galvanic isolation	Yes Fig. 9

Ethernet short description

The Ethernet interface is configured in the Automation Builder. For further information on the Ethernet interface for the respective CPU used, please refer to the AC500 documentation.

Ethernet system

The general information about the Ethernet system is still valid. For further information on Ethernet, please refer to the AC500 documentation.

Pin assignment

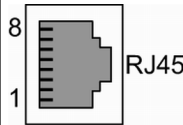
	PIN	Signal	Description
 RJ45	1	TxD+	Transmit data +
	2	TxD-	Transmit data -
	3	RxD+	Receive data +
	4	NU	Not used
	5	NU	Not used
	6	RxD-	Receive data -
	7	NU	Not used
	8	NU	Not used
	Shield	Cable shield	Functional earth



NOTICE!

Risk of corrosion!

Unused connectors and slots may corrode if XC devices are used in salt-mist environments.

Protect unused connectors and slots with TA535 protective caps for XC devices.

1.5 Replacement devices: I/O modules

For AC31 devices of the 90 series, AC31 adapters (replacement devices) are available for the exchange of individual I/O modules.

1.5.1 Replacement device 07AC91-AD

1.5.1.1 Introduction

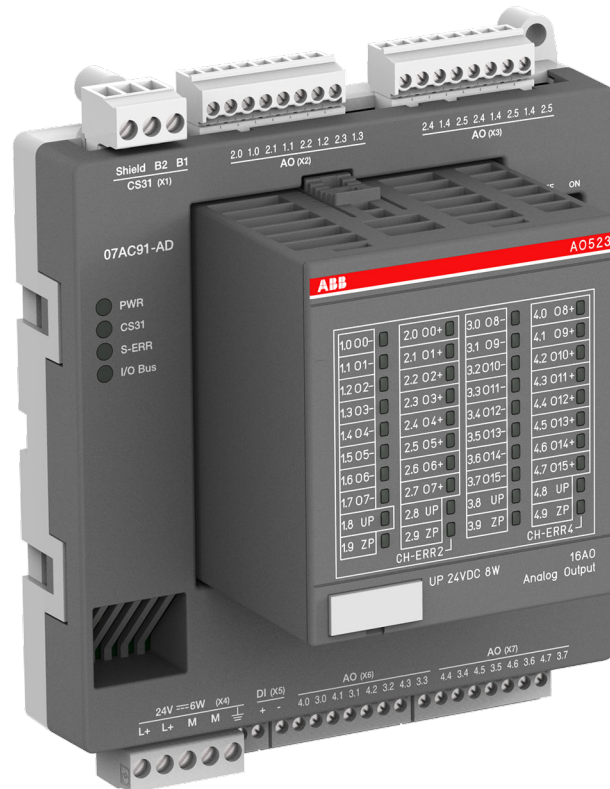

Fig. 26: 3ADR331193S0015_07AC91-AD

The replacement device 07AC91-AD of the AC31 adapter series replaces the existing device 07AC91 of the AC31/90 series in operating mode **8 bit**. The replacement device 07AC91-AD2 is available for operating mode **12 bit**.

During the development of the replacement device, care was taken to keep the device configuration identical to the configuration of the existing device. Thus, the existing documentation of device 07AC91 remains valid and serves as reference ([system description Advant Controller 31](#)).

The document structure of this document is based on the document structure of the existing documentation.

This document adds the following points to the still valid existing documentation:

- Unavoidable device deviations, e.g. due to technical limitations.
- Expansion of documentation as a result of normative requirements.
- Additional contents not described in the existing documentation.

Further information on replacement device 07DC91-AD can be found in the operating and assembly instructions of device 07DC91-AD: 3ADR020084M0401. Please note that for the existing device 07AI91 no separate operating and assembly instructions are available.

Please also observe the system data as well as the information on CS31 bus ↪ [Chapter 1.3 "System data and CS31 bus system data"](#) on page 4.

1.5.1.2 Device configuration

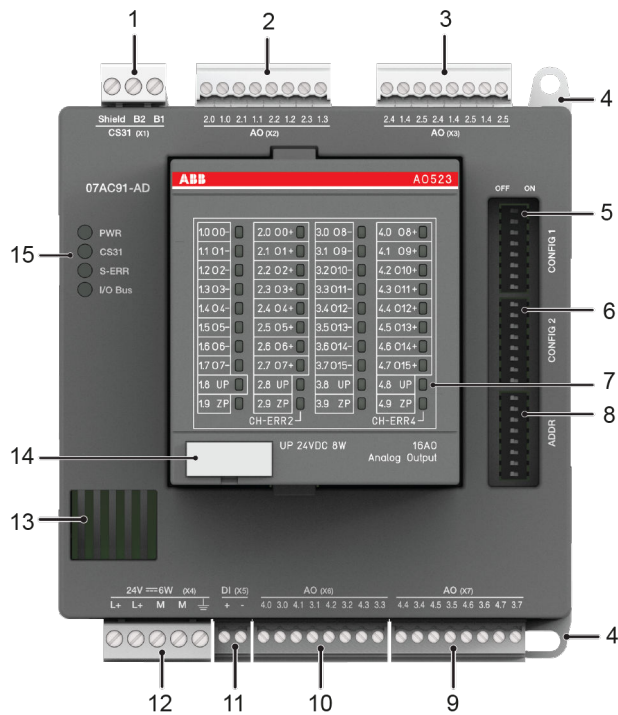

- 1 Connection for CS31 bus (X1)
- 2 Analog outputs (X2): 0 ... 10 V, 0 ... 20 mA
- 3 Analog outputs (X3): 0 ... 10 V
- 4 Hole for screw mounting (screw diameter 4 mm, extension torque 1.2 Nm)
- 5 DIP switch for CONFIG1
- 6 DIP switch for CONFIG2
- 7 Status LEDs for AO523
- 8 DIP switch for ADDR
- 9 Analog outputs (X7): 0 ... 10 V
- 10 Analog outputs (X6): 0 ... 10 V, 0 ... 20 mA
- 11 Enabling input for analog outputs (X5)
- 12 Supply 24 V DC (incl. AO523)
- 13 Ventilation
- 14 TA525: Label
- 15 4 Status LEDs

1.5.1.2.1 LED display

The LED display on the replacement device is changed:

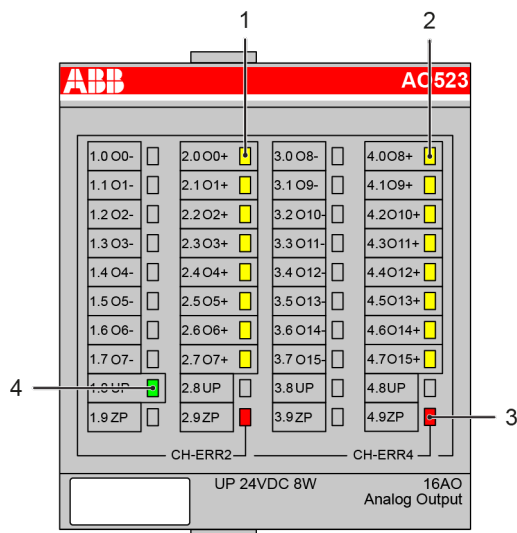

Fig. 27: AO523

No.	Display of module
1	8 yellow LEDs to indicate the signal state of the analog inputs (X2 and X3)
2	8 yellow LEDs to indicate the signal state of the analog inputs (X6 and X7)
3	2 red LEDs to indicate errors (of AO523 module)
4	1 green LED to indicate the status of the supply voltage of the AO523 module (is supplied via X4)



The replacement device does not provide a test button to measure functionality.

Table 28: Pin assignment AO (X2)

Connector / Terminal	Pin	Assignment / Signal
X2 / 2.0	4	AO523 / O0+
X2 / 1.0	5	AO523 / O0- (AGND)
X2 / 2.1	6	AO523 / O1+
X2 / 1.1	7	AO523 / O1- (AGND)
X2 / 2.2	8	AO523 / O2+
X2 / 1.2	9	AO523 / O2- (AGND)
X2 / 2.3	10	AO523 / O3+
X2 / 1.3	11	AO523 / O3- (AGND)

Table 29: Pin assignment AO (X3)

Connector / Terminal	Pin	Assignment / Signal
X3 / 2.4	12	AO523 / -
X3 / 1.4	13	AO523 / O4- (AGND)
X3 / 2.5	14	AO523 / -
X3 / 1.5	15	AO523 / O5- (AGND)
X3 / 2.6	16	AO523 / -
X3 / 1.6	17	AO523 / O6- (AGND)
X3 / 2.7	18	AO523 / -
X3 / 1.7	19	AO523 / O7- (AGND)

Table 30: Pin assignment 24 V DC 9W (X4)

Connector / Terminal	Pin	Assignment / Signal
X4 / L+	20	L+
X4 / L+	21	L+
X4 / M	22	M
X4 / M	23	M
X4 / FE	24	FE

Table 31: Pin assignment DI (X5)

Connector / Terminal	Pin	Assignment / Signal
X5 / +	25	IN+
X5 / -	26	IN- (galvanic isolated ground)

Table 32: Pin assignment AO (X6)

Connector / Terminal	Pin	Assignment / Signal
X6 / 4.0	27	AO523 / O8+
X6 / 3.0	28	AO523 / O8- (AGND)
X6 / 4.1	29	AO523 / O9+
X6 / 3.1	30	AO523 / O9- (AGND)
X6 / 4.2	31	AO523 / O10+
X6 / 3.2	32	AO523 / O10- (AGND)
X6 / 4.3	33	AO523 / O11+
X6 / 3.3	34	AO523 / O11- (AGND)

Table 33: Pin assignment AO (X7)

Connector / Terminal	Pin	Assignment / Signal
X7 / 4.4	35	AO523 / O12+
X7 / 3.4	36	AO523 / O12- (AGND)
X7 / 4.5	37	AO523 / O13+
X7 / 3.5	38	AO523 / O13- (AGND)
X7 / 4.6	39	AO523 / O14+
X7 / 3.6	40	AO523 / O14- (AGND)
X7 / 4.7	41	AO523 / O15+
X7 / 3.7	42	AO523 / O15- (AGND)

The signals Ox- are internally linked to an AGND area. The potential AGND is connected to the potential M via PTC resistors. Potential difference AGND to M ± 1 V (max.).

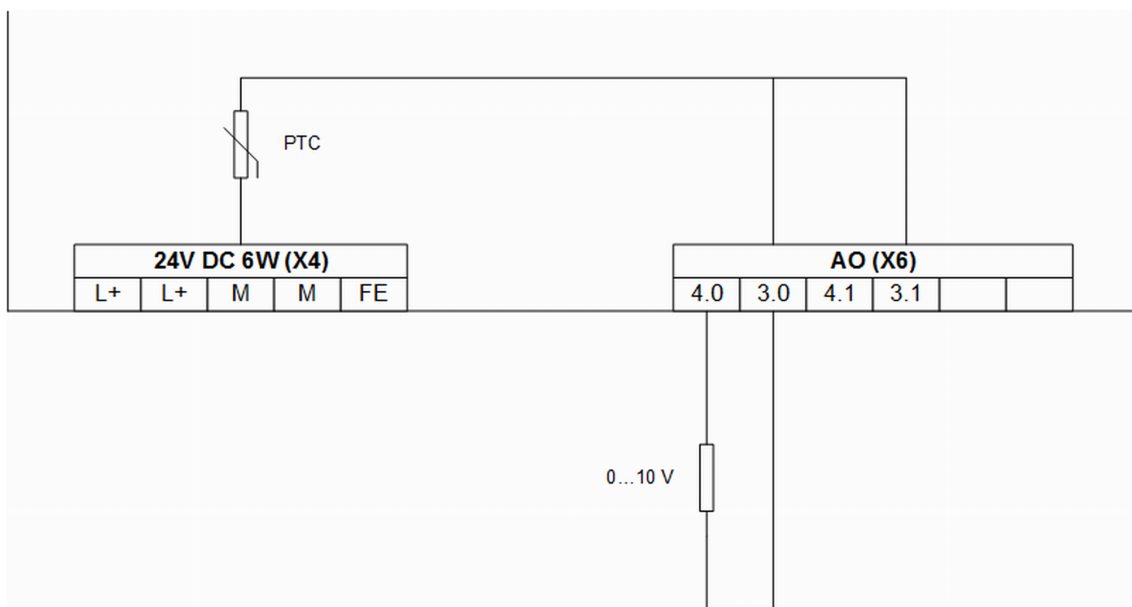

Fig. 29: Voltage output

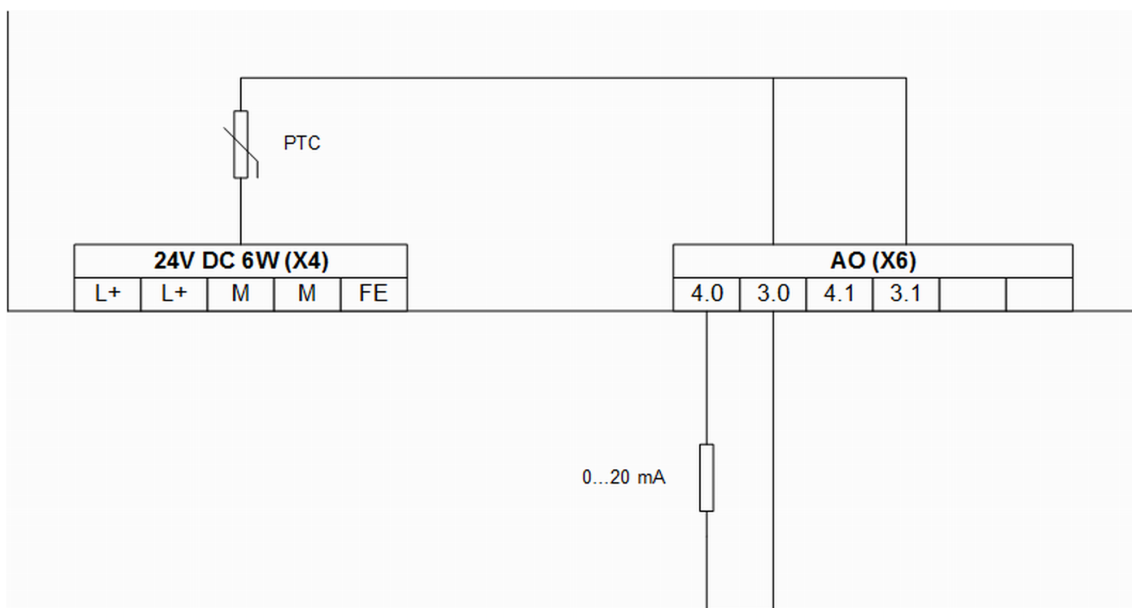



Fig. 30: Current output

 *Analog signal lines must be routed in shielded cables. The shield must be grounded on both sides and should be grounded to replacement device and signal source / signal sink as close as possible.*

1.5.1.2.3 Configuration

The existing device had a DIP switch on the upper printed circuit board. Since the replacement device is not equipped with an upper printed circuit board, the white DIP switch is arranged on the lower printed circuit board instead.

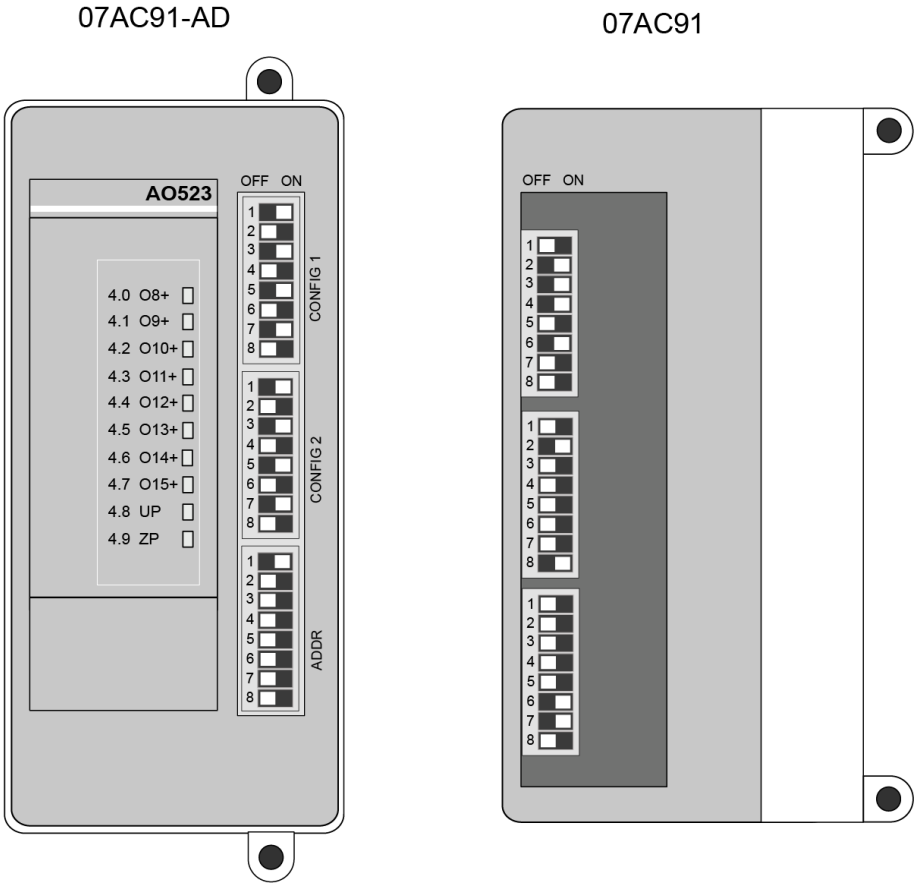

Table 34: Example configuration for 07AC91-AD:

Config 1	All output channels on voltage.
Config 2	All output channels on voltage.
ADDR	8-bit mode, without range monitoring, CS31 address 0 and channel number ≤ 7.

Configuration areas with (white) DIP switches

Please observe the following:

- All channels must be configured as outputs.
- The position of the DIP switches are read by the device only once after the supply voltage has been connected.

Config 1	The DIP switches for the channels 1, 3, 5 and 7 must be set to ON (configuration as outputs). A configuration as inputs is not permitted.
	The DIP switches for the channels 2 and 4 can be set as desired. The outputs 0..3 may be set to OFF (voltage) or ON (current).
	The DIP switches for channels 6 and 8 must be set to OFF. The outputs 4..7 must be set to OFF (voltage). The setting to ON (current) is not permitted.
Config 2	The DIP switches for the channels 1, 3, 5 and 7 must be set to ON (configuration as outputs). A configuration as inputs is not permitted.
	The DIP switch position for the channels 2 and 4 can be set as desired. The outputs 8..11 may be set to OFF (voltage) or ON (current).
	The DIP switches for the channels 6 and 8 must be set to OFF. The outputs 12..15 must be set to OFF (voltage). The setting to ON (current) is not permitted.
ADDR	The DIP switch for channel 1 must be set to ON (8-bit mode).
	The DIP switch for channel 2 can be set as desired (no functionality).
	The DIP switch for channel 3 can be set as desired for range monitoring.
	The DIP switches for the channels 4-7 can be set as desired for the CS31 address.
	The DIP switch for channel 8 must be set to OFF for CS31 channels ≤ 7 . Channels > 7 are not supported. The outputs on connector X3 and X7 cannot be configured as current outputs.



For further information, please refer to the existing documentation [System description Advant Controller 31](#).

1.5.1.2.4 Measuring ranges of the analog channels

For the replacement device 07AC91-AD, only the operating mode "8 bit" is relevant.

The outputs of the S500 module AO523 have a 12 bit resolution. The values that are to be transmitted via the CS31 bus and output by the replacement device have only a 8 bit resolution. For this reason, the overall resolution achieved is only 8 bits.

1.5.1.2.5 Addressing



The function of the address DIP switch 8 (channel No. ≤ 7 or channel No. > 7) is no longer supported.

In the following, the information in the "Type" column refers to the data type designation of the Automation Builder (see AC31 system data [Chapter 1.3 "System data and CS31 bus system data" on page 4](#)). The information in the "Type" column must be interpreted from the viewpoint of the CS31 bus master. The information in brackets must be interpreted from the viewpoint of the replacement device (CS31 bus slave).

Table 35: CS31 bus

Type	Byte	Position in WORD	Connector / Terminal
WORD output (received) 0	1	High	X2 / 2.1
	2	Low	X2 / 2.0
WORD output (received) 1	3	High	X2 / 2.3
	4	Low	X2 / 2.2
WORD output (received) 2	5	High	X3 / 2.5
	6	Low	X3 / 2.4
WORD output (received) 3	7	High	X3 / 2.7
	8	Low	X3 / 2.6
WORD output (received) 4	9	High	X6 / 4.1
	10	Low	X6 / 4.0
WORD output (received) 5	11	High	X6 / 4.3
	12	Low	X6 / 4.2
WORD output (received) 6	13	High	X7 / 4.5
	14	Low	X7 / 4.4
WORD output (received) 7	15	High	X7 / 4.7
	16	Low	X7 / 4.6

1.5.1.2.6 Behavior during normal operation

Interpretation of the LEDs:

- The device initializes automatically after the supply voltage is switched on. During this time, the S-ERR LED flashes.
- The PWR LED lights up as soon as the internal supply voltage of the device is present.
- After successful initialization of the I/O bus communication to the S500 module, the I/O bus LED lights up.
- After successful initialization of the CS31 bus communication, the CS31 bus LED lights up. The S-ERR LED goes out.
- During operation, the yellow LEDs indicate the signal states of the channels.

The RAM is checked during the initialization of the device. In addition, the firmware in the flash memory is checked by means of a checksum during initialization. When the control system (PLC/central unit) is stopped during normal operation, the outputs of the device are switched off. The outputs are also switched off in case of a malfunction of the CS31 bus.

1.5.1.2.7 Diagnosis and display

LEDs are used for diagnosis and display purposes. In addition, some diagnosis information can be transmitted via the CS31 bus.

	<p><i>The replacement device does not provide a test button to measure functionality.</i></p>
---	---

Table 36: Diagnosis information of the CS31 bus

Channel	Error code (CODESYS)	Error code (CS31 bus)	Description
Device error:			
0	43	1	Internal error



The error codes that are transferred by the replacement device via the CS31 bus are newly displayed in CODESYS. Each error code of the CS31 bus (table column 3) produces the error code in CODESYS (table column 2). As a result, it is possible to operate the replacement device with a new control system (PLC/control unit), e.g. 07KT98-ARC-AD, as well as with an old control system (PLC/central unit), e.g. 07KT98.

Table 37: Device LEDs

LED	Status	Color	LED off	LED on	LED flashes
PWR	Voltage supply	Green	No internal supply voltage	Internal supply voltage	-
CS31 bus	CS31 bus communication	Green	No CS31 bus communication	CS31 bus communication	Only diagnosis, no data transfer. Transmission is disturbed.
S-ERR	Error	Red	No error	Static error (must be confirmed by the control system)	No CS31 bus connection or activity
I/O bus	I/O bus communication	Green	No I/O bus communication	I/O bus communication	Error I/O bus communication

The S-ERR LED remains on even if the error no longer occurs. The error must be confirmed by the control system (PLC/central unit), e.g. by means of a function block ↗ Chapter 1.3 “System data and CS31 bus system data” on page 4.

Special cases with rapidly flashing LEDs (approx. 5 Hz):

- All 4 LEDs flash rapidly: An incorrect S500 module is connected to the device. The device fails to initialize.
- The LEDs of the CS31 bus, S-ERR bus and I/O bus flash rapidly: Invalid position of DIP switches. The device fails to initialize.
- The LEDs of the S-ERR bus and I/O bus flash rapidly: A checksum error occurred in an internal flash memory.
- The LED of the I/O bus flashes rapidly: An error occurred in an internal RAM.

Table 38: S500 module AO523 LEDs

LED	Status	Color	LED off	LED on	LED flashes
O0+...O7+ O8+...O15+ (see No. 1 + 2 in the following figure)	Analog outputs	Yellow	Output is not activated	Output is activated (brightness depends on value of analog signal).	-
Error indication left (see No. 3 in the following figure)	Error indication	Red	No error	Internal error	-

LED	Status	Color	LED off	LED on	LED flashes
Error indication right (see No. 3 in the following figure)	Error indication	Red	No error	Internal error	-
Indication supply voltage (see No. 4 in the following figure)	Process voltage	Green	Process voltage not available	Process voltage OK	-

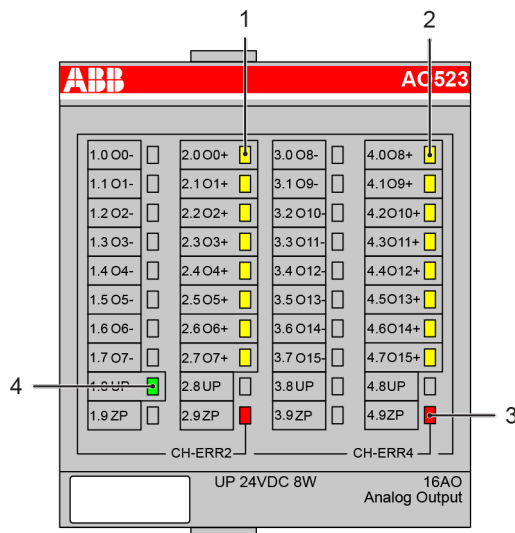

Fig. 31: AO523

1.5.1.2.8 Technical data

This section provides additional information on section [Chapter 1.3 “System data and CS31 bus system data” on page 4](#). In case of doubt, the following information applies.

For the device 07AC91-AD, only the operating mode "8 bit" is relevant.

Technical data of the complete device

Data	Value
Process voltage:	
-> Connections	X4/L+ (pin 20), X4/L+ (pin 21), X4/M (pin 22), X4/M (pin 23)
-> Fuse for L+	10 A, fast acting
- Galvanic isolation	No
Current consumption:	
-> via L+	0.19 A + output load

Data	Value
- Inrush current via L+ (when voltage is switched on)	0.18 A ² s
Power consumption	Replacement device: 9 W Existing device: 5 W



For further information, please refer to the existing documentation [System description Advant Controller 31](#).



CAUTION!

System damage caused by voltage!

Exceeding the maximum supply or process voltage (>30 V DC) results in permanent system damage (destruction).

Technical data of the binary input

Data	Value
Input current at input voltage +24 V	Typ. 6 mA
Protection against reversed voltage	Yes
Overvoltage protection	No

The enabling input is a proprietary input.



For further information, please refer to the existing documentation [System description Advant Controller 31](#).

Technical data of the analog outputs

Data	Value
Connections	X2 / 2.0, X2 / 2.1, X2 / 2.2, X2 / 2.3, X3 / 2.4, X3 / 2.5, X3 / 2.6, X3 / 2.7, X6 / 4.0, X6 / 4.1, X6 / 4.2, X6 / 4.3, X7 / 4.4, X7 / 4.5, X7 / 4.6, X7 / 4.7
Reference connections (AGND)	X2 / 1.0, X2 / 1.1, X2 / 1.2, X2 / 1.3, X3 / 1.4, X3 / 1.5, X3 / 1.6, X3 / 1.7, X6 / 3.0, X6 / 3.1, X6 / 3.2, X6 / 3.3, X7 / 3.4, X7 / 3.5, X7 / 3.6, X7 / 3.7
Type of outputs	Voltage unipolar, current unipolar
Configurability	No inputs are available Replacement device: 8 current outputs Existing device: 16 current outputs
Output load capability, as voltage output	Replacement device: ± 10 mA Existing device: +20 mA, -10 mA

Data	Value
Short-circuit-proof	Yes
External supply protection	Up to 30 V DC



For further information, please refer to the existing documentation System description Advant Controller 31.

Connection to the CS31 bus

Data	Value
Connections	X1/B2, X1/B1
CS31 bus type	03 (analog output)
Terminating resistor	Not available (must be provided externally if needed)

Mechanical data

Data	Value
Width x height x depth	Replacement device: 120 x 140 x approx. 80 mm Existing device: 120 x 140 x 85 mm
Weight	Replacement device: 363 g Existing device: 450 g
Dimensions for mounting	See assembly instructions 07AC91-AD (3ADR020084M0401)

Mounting information

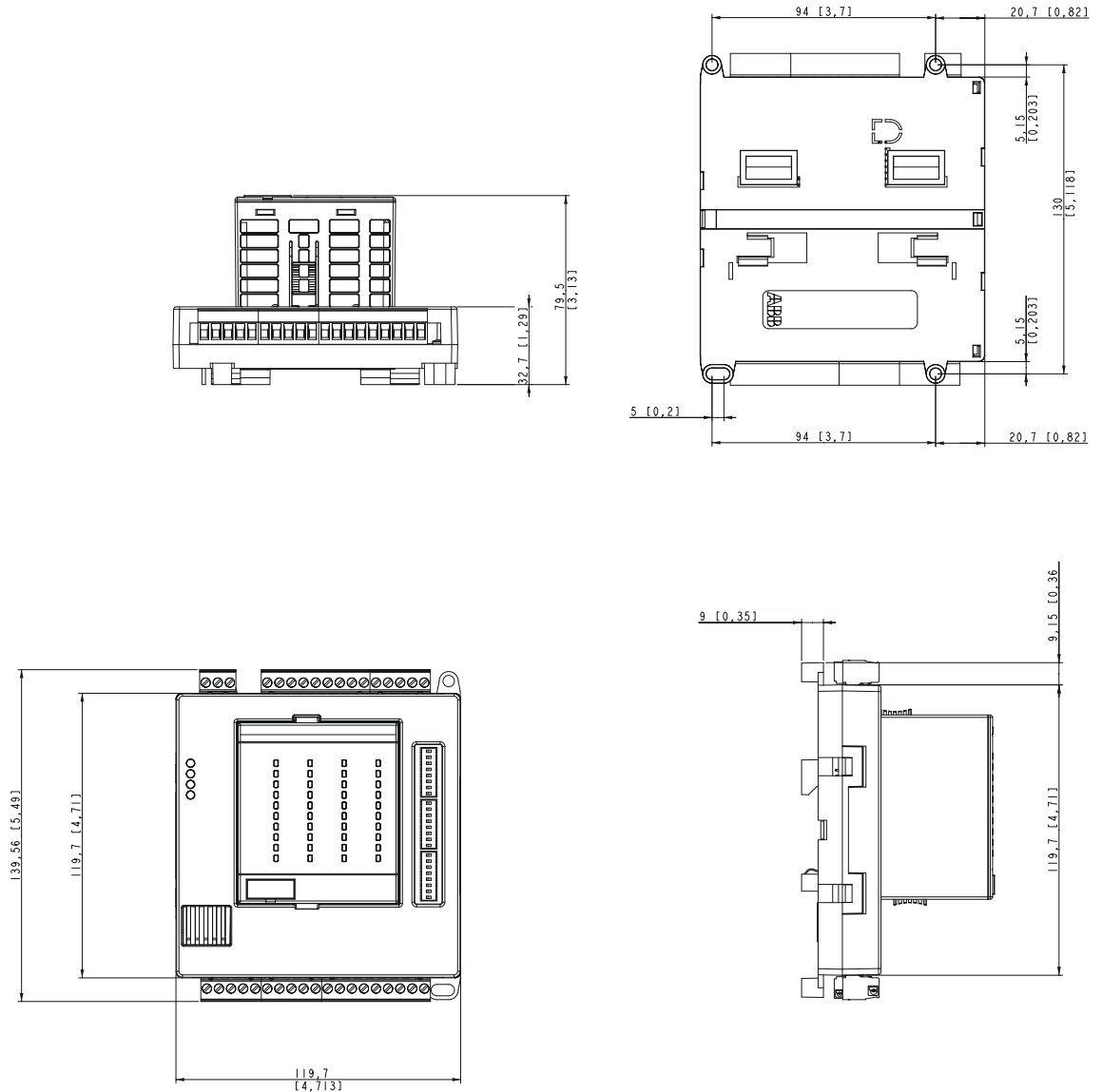

The dimensions are in mm and in brackets in inch.



The dimensions for the assembly holes are the same for the replacement device and the existing device.

To assemble or disassemble the replacement device, grab the device at the housing and not directly at the S500 module.

Ordering data

Order No.	Scope of delivery
1SAP 800 000 R0010	Analog output module 07AC91-AD 1 2-pole terminal block (3.81 mm grid space) 1 3-pole terminal block (5.08 mm grid space) 1 5-pole terminal block (5.08 mm grid space) 4 8-pole terminal blocks (3.81 mm grid space)

1.5.2 Replacement device 07AC91-AD2

1.5.2.1 Introduction

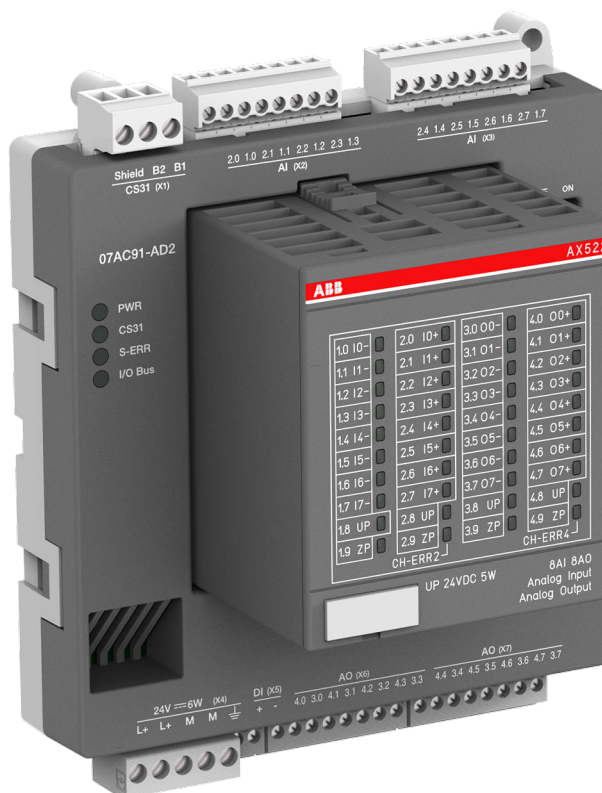

Fig. 32: 3ADR331194S0015_07AC91-AD2

The replacement device 07AC91-AD2 of the AC31 adapter series replaces the existing device 07AC91 of the AC31/90 series in operating mode **12 bit**. The replacement device 07AC91-AD is available for operating mode **8 bit**.

During the development of the replacement device, care was taken to keep the device configuration identical to the configuration of the existing device. Thus, the existing documentation of device 07AC91 remains valid and serves as reference (*system description Advant Controller 31*). The document structure of this document is based on the document structure of the existing documentation.

This document adds the following points to the still valid existing documentation:

- Unavoidable device deviations, e.g. due to technical limitations.
- Expansion of documentation as a result of normative requirements.
- Additional contents not described in the existing documentation.

Further information on replacement device 07AC91-AD2 can be found in the operating and assembly instructions of device 07AC91-AD2: 3ADR020085M0401. Please note that for the existing device 07AI91 no separate operating and assembly instructions are available.

Please also observe the system data as well as the information on CS31 bus [Chapter 1.3 "System data and CS31 bus system data"](#) on page 4.



Please observe the information contained in the existing documentation. In section "Fig. 5.4-2: Connection of the analog input/output module 07AC91", only the information concerning operating mode 12 bit is relevant for the replacement device 07AC91-AD2.

1.5.2.2 Device configuration

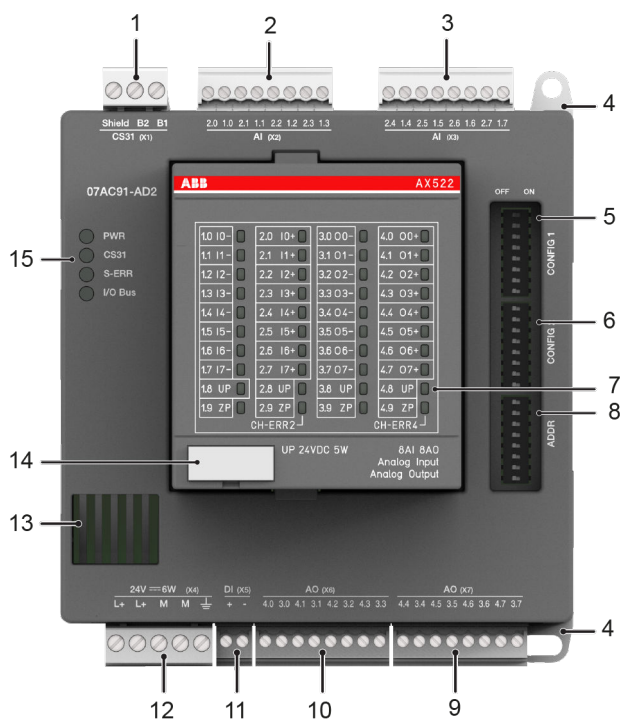

- 1 Connection for CS31 bus (X1)
- 2 Analog inputs (X2): -10 V...+10 V, 0...20 mA
- 3 Analog inputs (X3): -10 V...+10 V, 0...20 mA
- 4 Hole for screw mounting (screw diameter 4 mm, extension torque 1.2 Nm)
- 5 DIP switch for CONFIG1
- 6 DIP switch for CONFIG2
- 7 Status LEDs for AX522
- 8 DIP switch for ADDR
- 9 Analog outputs (X7): -10 V...+10 V
- 10 Analog outputs (X6): -10 V...+10 V, 0...20 mA
- 11 Enabling input for analog outputs (X5)
- 12 Supply 24 V DC (incl. AX522)
- 13 Ventilation
- 14 TA525: Label
- 15 4 Status LEDs

1.5.2.2.1 LED display

The LED display on the replacement device is changed:

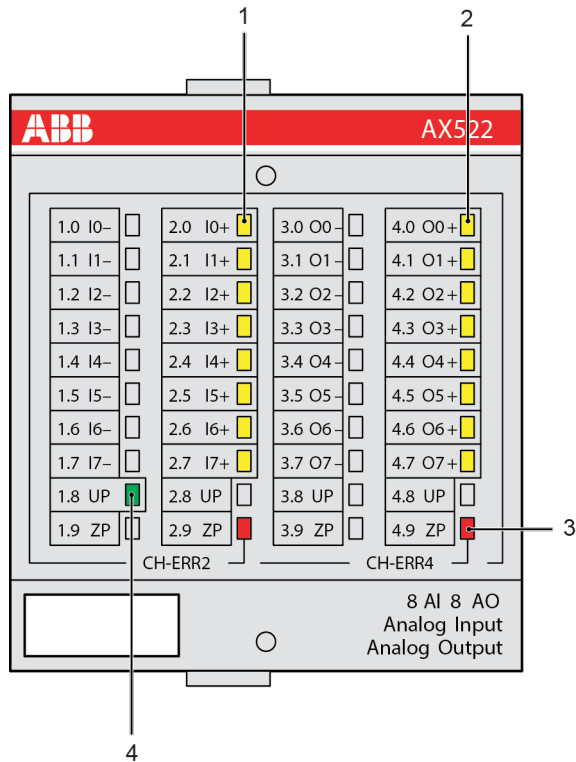



Fig. 33: AX522

No.	Display of module
1	8 yellow LEDs to indicate the signal states of the analog inputs (X2 and X3)
2	8 yellow LEDs to indicate the signal states of the analog inputs (X6 and X7)
3	2 red LEDs to indicate errors (of AX522 module)
4	1 green LED to indicate the status of the supply voltage of the AX522 module (is supplied via X4)

 *The replacement device does not provide a test button to measure functionality.*

1.5.2.2.2 Connections

 *Please observe the information contained in the existing documentation. In section "Fig. 5.4-2: Connection of the analog input/output module 07AC91", only the information concerning operating mode 12 bit is relevant for the replacement device 07AC91-AD2.*

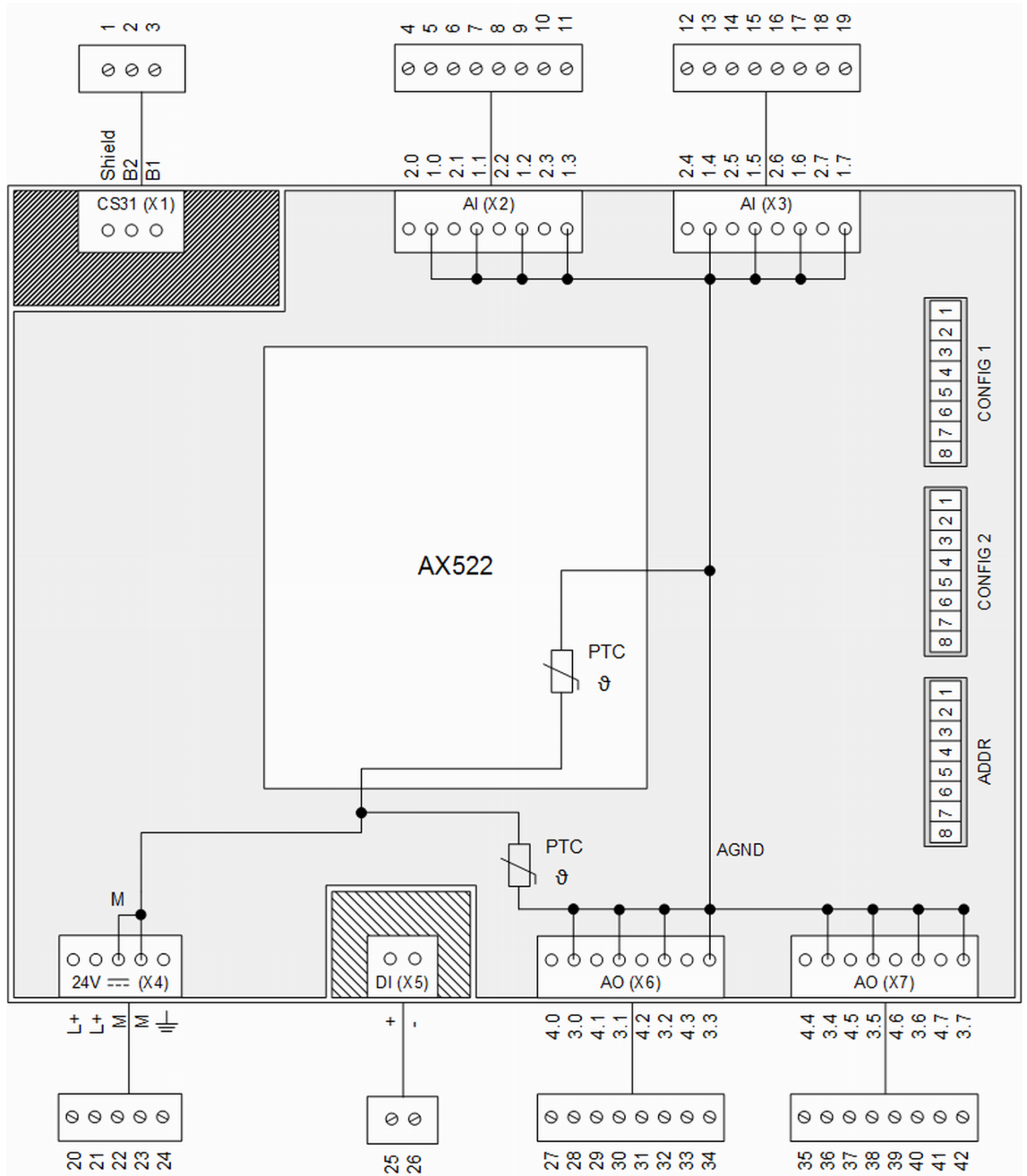

Fig. 34: Connection

Table 39: Pin assignment CS31 bus (X1)

Connector / Terminal	Pin	Assignment / Signal
X1 / Shield	1	No internal connection
X1 / B2	2	BUS 2
X1 / B1	3	BUS 1

Table 40: Pin assignment AI (X2)

Connector / Terminal	Pin	Assignment / Signal
X2 / 2.0	4	AX522 / IO+
X2 / 1.0	5	AX522 / IO- (AGND)

Connector / Terminal	Pin	Assignment / Signal
X2 / 2.1	6	AX522 / I1+
X2 / 1.1	7	AX522 / I1- (AGND)
X2 / 2.2	8	AX522 / I2+
X2 / 1.2	9	AX522 / I2- (AGND)
X2 / 2.3	10	AX522 / I3+
X2 / 1.3	11	AX522 / I3- (AGND)

Table 41: Pin assignment AI (X3)

Connector / Terminal	Pin	Assignment / Signal
X3 / 2.4	12	AX522 / I4+
X3 / 1.4	13	AX522 / I4- (AGND)
X3 / 2.5	14	AX522 / I5+
X3 / 1.5	15	AX522 / I5- (AGND)
X3 / 2.6	16	AX522 / I6+
X3 / 1.6	17	AX522 / I6- (AGND)
X3 / 2.7	18	AX522 / I7+
X3 / 1.7	19	AX522 / I7- (AGND)

Table 42: Pin assignment 24 V DC 6W (X4)

Connector / Terminal	Pin	Assignment / Signal
X4 / L+	20	L+
X4 / L+	21	L+
X4 / M	22	M
X4 / M	23	M
X4 / FE	24	FE

Table 43: Pin assignment DI (X5)

Connector / Terminal	Pin	Assignment / Signal
X5 / +	25	IN+
X5 / -	26	IN- (galvanic isolated ground)

Table 44: Pin assignment AO (X6)

Connector / Terminal	Pin	Assignment / Signal
X6 / 4.0	27	AX522 / O0+
X6 / 3.0	28	AX522 / O0- (AGND)
X6 / 4.1	29	AX522 / O1+
X6 / 3.1	30	AX522 / O1- (AGND)
X6 / 4.2	31	AX522 / O2+
X6 / 3.2	32	AX522 / O2- (AGND)
X6 / 4.3	33	AX522 / O3+
X6 / 3.3	34	AX522 / O3- (AGND)

Table 45: Pin assignment AO (X7)

Connector / Terminal	Pin	Assignment / Signal
X7 / 4.4	35	AX522 / O4+
X7 / 3.4	36	AX522 / O4- (AGND)
X7 / 4.5	37	AX522 / O5+
X7 / 3.5	38	AX522 / O5- (AGND)
X7 / 4.6	39	AX522 / O6+
X7 / 3.6	40	AX522 / O6- (AGND)
X7 / 4.7	41	AX522 / O7+
X7 / 3.7	42	AX522 / O7- (AGND)



The outputs on connector X7 cannot be configured as current outputs.

The signals Ix- and Ox- are internally linked to an AGND area. The potential AGND is connected to the potential M via PTC resistors. Potential difference AGND to M ± 1 V maximal.

To enable wire-break detection, each input is internally pulled to "plus" by means of a high-impedance resistor. As a result, the maximum voltage is read when nothing is connected. Do not replace the AX522 module while voltage is connected.

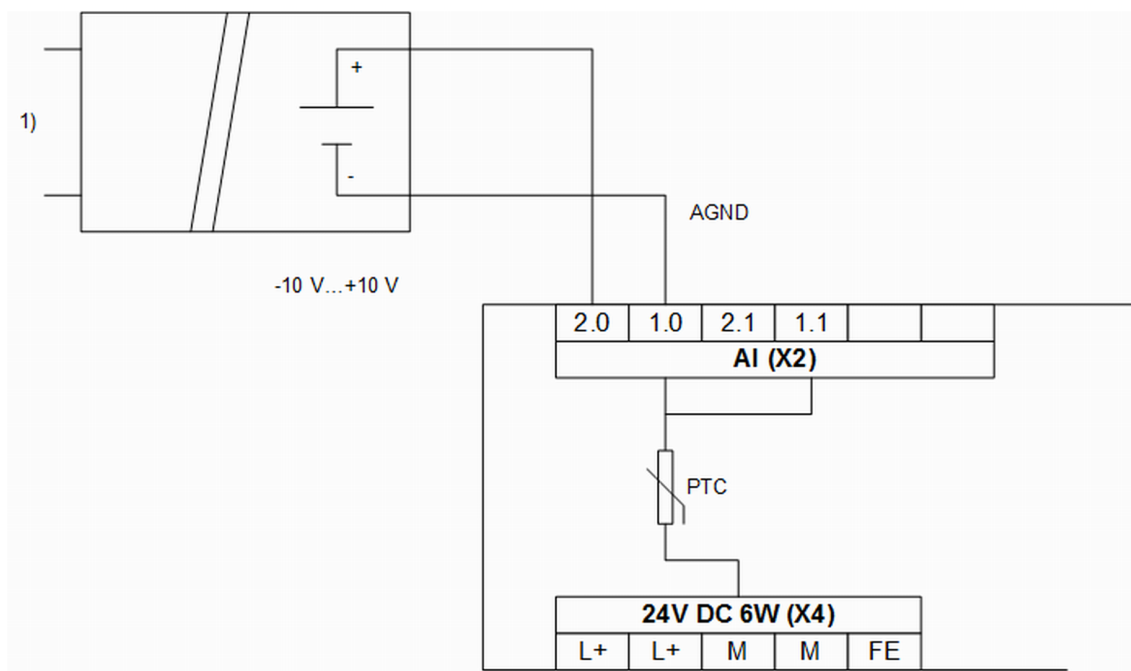

Fig. 35: Voltage input

- 1) Galvanically isolated power supply of analog sensor

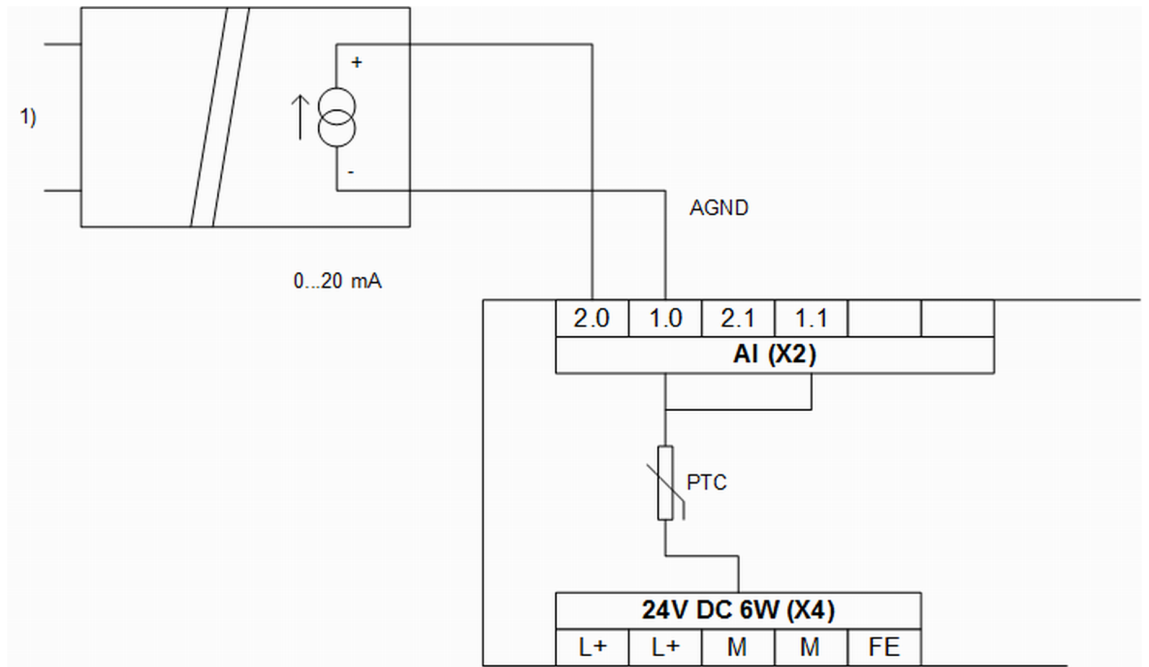

Fig. 36: Current input

1) Galvanically isolated power supply of analog sensor

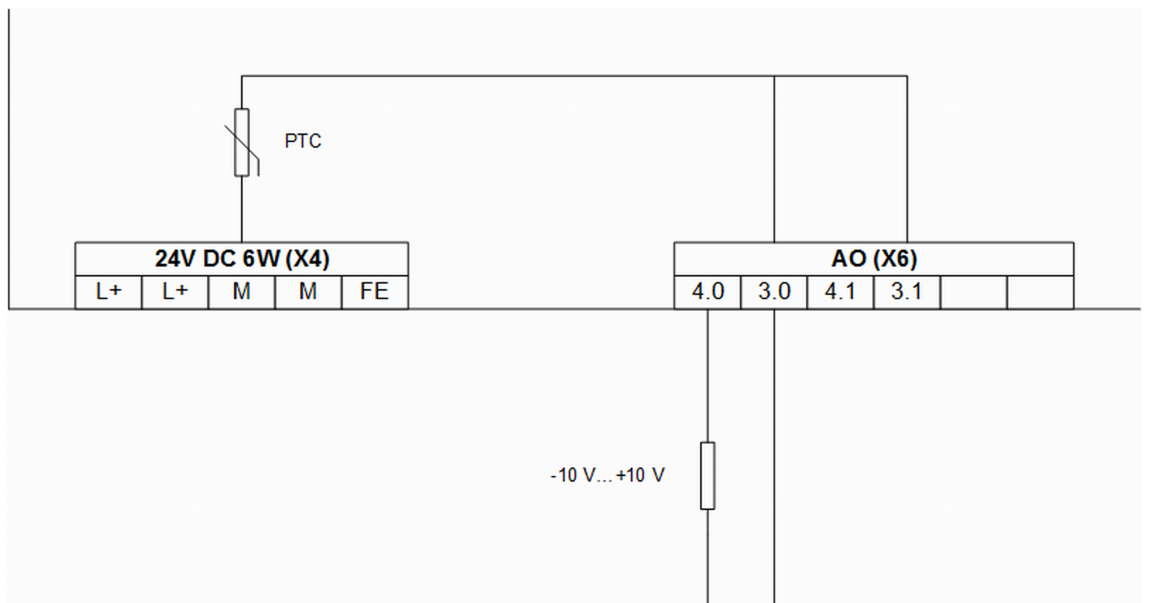

Fig. 37: Voltage output

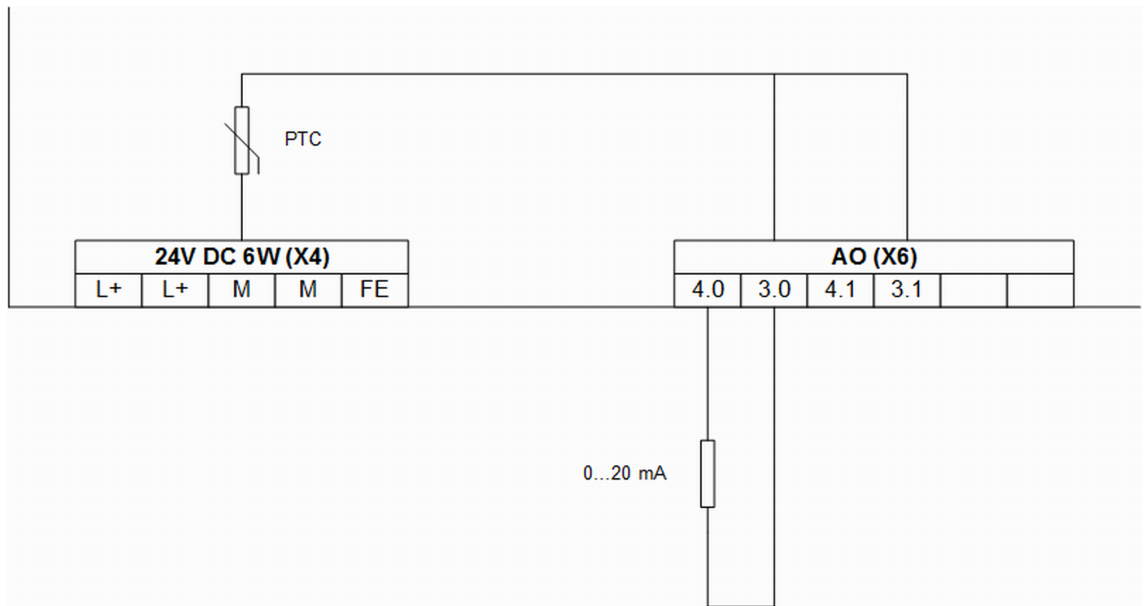

Fig. 38: Current output



Analog signal lines must be routed in shielded cables. The shield must be grounded on both sides and should be grounded to replacement device and signal source / signal sink as close as possible.

1.5.2.2.3 Configuration

The existing device had a DIP switch on the upper printed circuit board. Since the replacement device is not equipped with an upper printed circuit board, the white DIP switch is arranged on the lower printed circuit board instead.

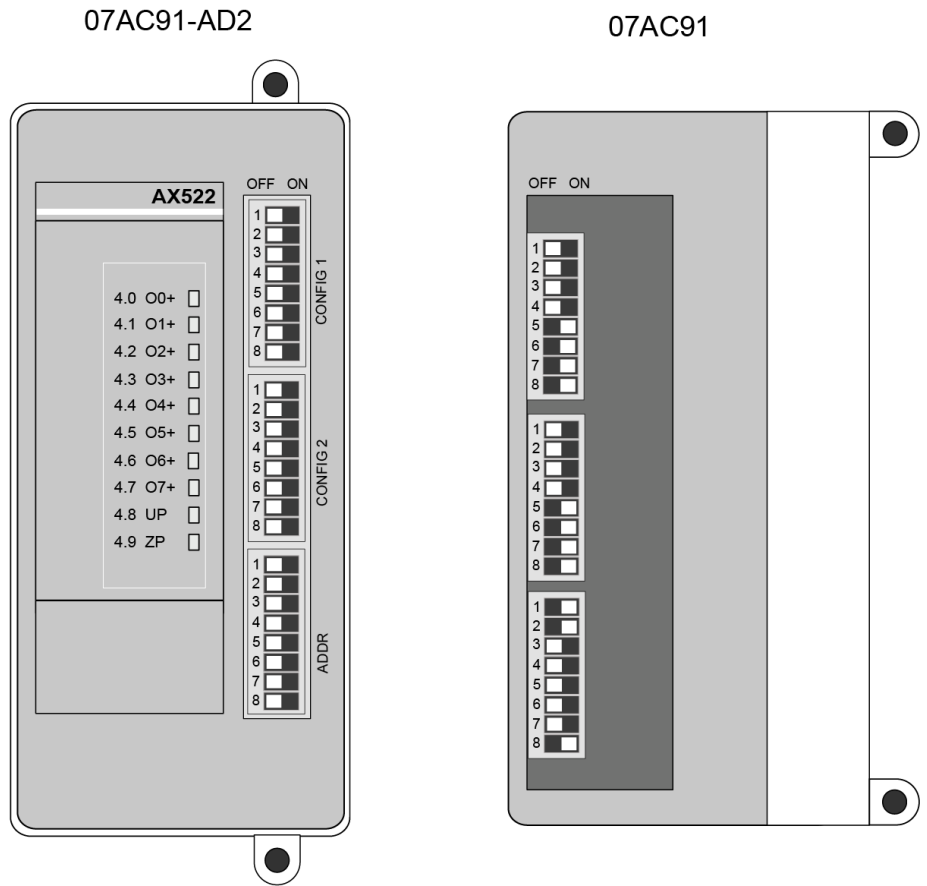

Table 46: Example configuration for 07AC91-AD2:

Config 1	All input channels set to ON (voltage).
Config 2	All output channels set to ON (voltage).
ADDR	12-bit mode, without range monitoring, CS31 address 0 and channel number ≤ 7 .

Configuration areas with (white) DIP switches

Please observe the following:

- Unused voltage inputs must be configured as current inputs (due to wire-break detection AX522 S500 module).
- The DIP switches are read by the device only once after the supply voltage has been connected.

Config 1	The DIP switches for all 8 channels (inputs) may be set to ON (current) or OFF (voltage).
Config 2	The DIP switches for the channels 1-4 (outputs 0..3) may be set to ON (current) or OFF (voltage).
	The DIP switches for the channels 5-8 (outputs 4..7) must be set to OFF (voltage). The setting ON (current) is not permitted.
ADDR	The DIP switch for channel 1 (operating mode) must be set to OFF (12-bit mode) .
	The DIP switch for channel 2 can be set as desired (no functionality).
	The DIP switch for channel 3 can be set as desired for range monitoring.

	The DIP switches for the channels 4-7 can be set as desired for the CS31 address.
	The DIP switch for channel 8 must be set to OFF for CS31 channels ≤ 7 . Channels > 7 are not supported. The outputs on connector X7 cannot be configured as current outputs.

 For further information, please refer to the existing documentation System description Advant Controller 31.

1.5.2.2.4 Measuring ranges of the analog channels

For the replacement device 07AC91-AD2, only the operating mode "12 bit" is relevant.

Measuring range:

- Inputs: ± 10 V and 0..20 mA
- Outputs for X6 (AW1.0..AW1.3): ± 10 V and 0..20 mA
- Outputs for X7 (AW1.4..AW1.7): ± 10 V

1.5.2.2.5 Addressing

 The function of the address DIP switch 8 (channel No. ≤ 7 or channel No. > 7) is no longer supported.

In the following, the information in the "Type" column refers to the data type designation of the Automation Builder (see AC31 system data [Chapter 1.3 "System data and CS31 bus system data" on page 4](#)). The information in the "Type" column must be interpreted from the viewpoint of the CS31 bus master. The information in brackets must be interpreted from the viewpoint of the replacement device (CS31 bus slave).

When the measuring values are bipolar, it is advisable to use the data type "INT input/output" instead of "WORD input/output".

Table 47: CS31 bus

Type	Byte	Connector / Terminal
WORD (send) 0	1	X2 / 2.0
	2	
WORD input (send) 1	3	X2 / 2.1
	4	
WORD input (send) 2	5	X2 / 2.2
	6	
WORD input (send) 3	7	X2 / 2.3
	8	
WORD input (send) 4	9	X3 / 2.4

Type	Byte	Connector / Terminal
	10	
WORD input (send) 5	11	X3 / 2.5
	12	
WORD input (send) 6	13	X3 / 2.6
	14	
WORD input (send) 7	15	X3 / 2.7
	16	
WORD output (received) 8	17	X6 / 4.0
	18	
WORD output (received) 9	19	X6 / 4.1
	20	
WORD output (received) 10	21	X6 / 4.2
	22	
WORD output (received) 11	23	X6 / 4.3
	24	
WORD output (received) 12	25	X7 / 4.4
	26	
WORD output (received) 13	27	X7 / 4.5
	28	
WORD output (received) 14	29	X7 / 4.6
	30	
WORD output (received) 15	31	X7 / 4.7
	32	

1.5.2.2.6 Behavior during normal operation

Interpretation of the LEDs:

- The device initializes automatically after the supply voltage is switched on. During this time, the S-ERR LED flashes.
- The PWR LED lights up as soon as the internal supply voltage of the device is present.
- After successful initialization of the I/O bus communication to the S500 module, the I/O bus LED lights up.
- After successful initialization of the CS31 bus communication, the CS31 bus LED lights up. The S-ERR LED goes out.
- During operation, the yellow LEDs indicate the signal states of the channels.

The RAM is checked during the initialization of the device. In addition, the firmware in the flash memory is checked by means of a checksum during initialization. When the control system (PLC/central unit) is stopped during normal operation, the outputs of the device are switched off. The inputs remain active. The outputs are also switched off in case of a malfunction of the CS31 bus.

1.5.2.2.7 Diagnosis and display

LEDs are used for diagnosis and display purposes. In addition, some diagnosis information can be transmitted via the CS31 bus.



The replacement device does not provide a test button to measure functionality.

Table 48: Diagnosis information of the CS31 bus

Channel	Error code (CODESYS)	Error code (CS31 bus)	Description
Device error:			
0	43	1	Internal error
Channel error:			
0 ... 7	49	10	Analog value is out of measuring range (on analog inputs)



The error codes that are transferred by the replacement device via the CS31 bus are newly displayed in CODESYS. Each error code of the CS31 bus (table column 3) produces the error code in CODESYS (table column 2). As a result, it is possible to operate the replacement device with a new control system (PLC/control unit), e.g. 07KT98-ARC-AD, as well as with an old control system (PLC/central unit), e.g. 07KT98.

An exceedance of the measuring range is signaled even if nothing is connected to an analog voltage input.

Table 49: Device LEDs

LED	Status	Color	LED off	LED on	LED flashes
PWR	Voltage supply	Green	No internal supply voltage	Internal supply voltage	-
CS31 bus	CS31 bus communication	Green	No CS31 bus communication	CS31 bus communication	Only diagnosis, no data transfer. Transmission is disturbed.
S-ERR	Error	Red	No error	Static error (must be confirmed by the control system)	No CS31 bus connection or activity
I/O bus	I/O bus communication	Green	No I/O bus communication	I/O bus communication	Error I/O bus communication

The S-ERR LED remains on even if the error no longer occurs. The error must be confirmed by the control system (PLC/central unit), e.g. by means of a function block  Chapter 1.3 "System data and CS31 bus system data" on page 4.

Special cases with rapidly flashing LEDs (approx. 5 Hz):

- All 4 LEDs flash rapidly: An incorrect S500 module is connected to the device. The device fails to initialize.
- The LEDs of the CS31 bus, S-ERR bus and I/O bus flash rapidly: Invalid position of DIP switches. The device fails to initialize.

- The LEDs of the S-ERR bus and I/O bus flash rapidly: A checksum error occurred in an internal flash memory.
- The LED of the I/O bus flashes rapidly: An error occurred in an internal RAM.

Table 50: S500 module AX522 LEDs

LED	Status	Color	LED off	LED on	LED flashes
I0+...I7+ (see No. 1 in the following figure)	Analog inputs	Yellow	Input is not activated	Input is activated (brightness depends on value of analog signal).	-
O0+...O7+ (see No. 2 in the following figure)	Analog outputs	Yellow	Output is not activated	Output is activated (brightness depends on value of analog signal).	-
Error indication left (see No. 3 in the following figure)	Error indication	Red	No error	Internal error	-
Error indication right (see No. 3 in the following figure)	Error indication	Red	No error	Internal error	-
Indication supply voltage (see No. 4 in the following figure)	Process voltage	Green	Process voltage not available	Process voltage OK	-

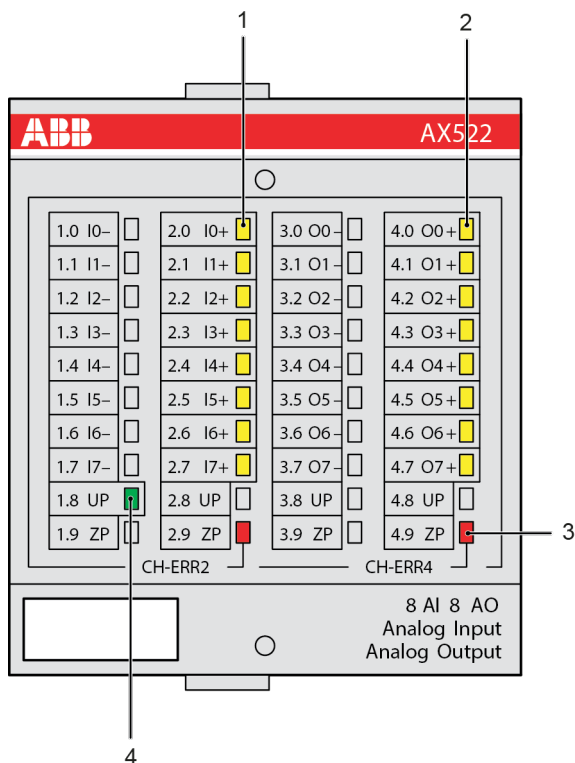

Fig. 39: AX522

1.5.2.2.8 Technical data

This section provides additional information on section [Chapter 1.3 “System data and CS31 bus system data” on page 4](#). In case of doubt, the following information applies.

For the device 07AC91-AD2, only the operating mode 12 bit is relevant.

Technical data of the complete device

Data	Value
Process voltage:	
-> Connections	X4/L+ (pin 20), X4/L+ (pin 21), X4/M (pin 22), X4/M (pin 23)
-> Fuse for L+	10 A, fast acting
- Galvanic isolation	No
Current consumption:	
-> via L+	0.19 A + output load
- Inrush current via L+ (when voltage is switched on)	0.16 A ² s
Power consumption	Replacement device: 6 W Existing device: 5 W



For further information, please refer to the existing documentation [System description Advant Controller 31](#).



CAUTION!

System damage caused by voltage!

Exceeding the maximum supply or process voltage (>30 V DC) results in permanent system damage (destruction).

Technical data of the binary input

Data	Value
Input current at input voltage +24 V	Typ. 6 mA
Protection against reversed voltage	Yes
Overvoltage protection	No

The enabling input is a proprietary input.



For further information, please refer to the existing documentation [System description Advant Controller 31](#).

Technical data of the analog inputs

Data	Value
Connections	X2 / 2.0, X2 / 2.1, X2 / 2.2, X2 / 2.3, X3 / 2.4, X3 / 2.5, X3 / 2.6, X3 / 2.7
Reference connections (AGND)	X2 / 1.0, X2 / 1.1, X2 / 1.2, X2 / 1.3, X3 / 1.4, X3 / 1.5, X3 / 1.6, X3 / 1.7
Type of inputs	Voltage bipolar, current unipolar
Time constant of the input filter	Voltage Replacement device: 100 μ s Existing device: 470 μ s
Conversion cycle *)	Replacement device: 2 ms (over 8 inputs + 8 outputs) Existing device: 8 ms
Resolution: range \pm 10 V	Replacement device: 2.4 mV, 12 bit + sign Existing device: 5 mV, 11 bit + sign
Protection against reversed voltage	Yes
Overvoltage protection	Up to 30 V DC

*) Conversion cycle of S500 module AX522. The transmission via serial buses is slower.



Unused voltage inputs must be configured as current inputs (due to wire-break detection AX522 S500 module).



For further information, please refer to the existing documentation [System description Advant Controller 31](#).

Technical data of the analog outputs

Data	Value
Connections	X6 / 4.0, X6 / 4.1, X6 / 4.2, X6 / 4.3, X7 / 4.4, X7 / 4.5, X7 / 4.6, X7 / 4.7
Reference connections (AGND)	X6 / 3.0, X6 / 3.1, X6 / 3.2, X6 / 3.3, X7 / 3.4, X7 / 3.5, X7 / 3.6, X7 / 3.7
Type of outputs	Voltage bipolar, current unipolar
Configurability	Replacement device: 4 current outputs available Existing device: 8 current outputs available
Output load capability, as voltage output	Replacement device: ± 10 mA Existing device: +20 mA, -10 mA
Short-circuit-proof	Yes
External supply protection	Up to 30 V DC



For further information, please refer to the existing documentation [System description Advant Controller 31](#).

Connection to the CS31 bus

Data	Value
Connections	X1/B2, X1/B1
CS31 bus type	05 (analog input/output)
Terminating resistor	Not available (must be provided externally if needed)

Mechanical data

Data	Value
Width x height x depth	Replacement device: 120 x 140 x approx. 80 mm Existing device: 120 x 140 x 85 mm
Weight	Replacement device: 362 g Existing device: 450 g
Dimensions for mounting	See assembly instructions 07AC91-AD2 (3ADR020085M0401)

Mounting information

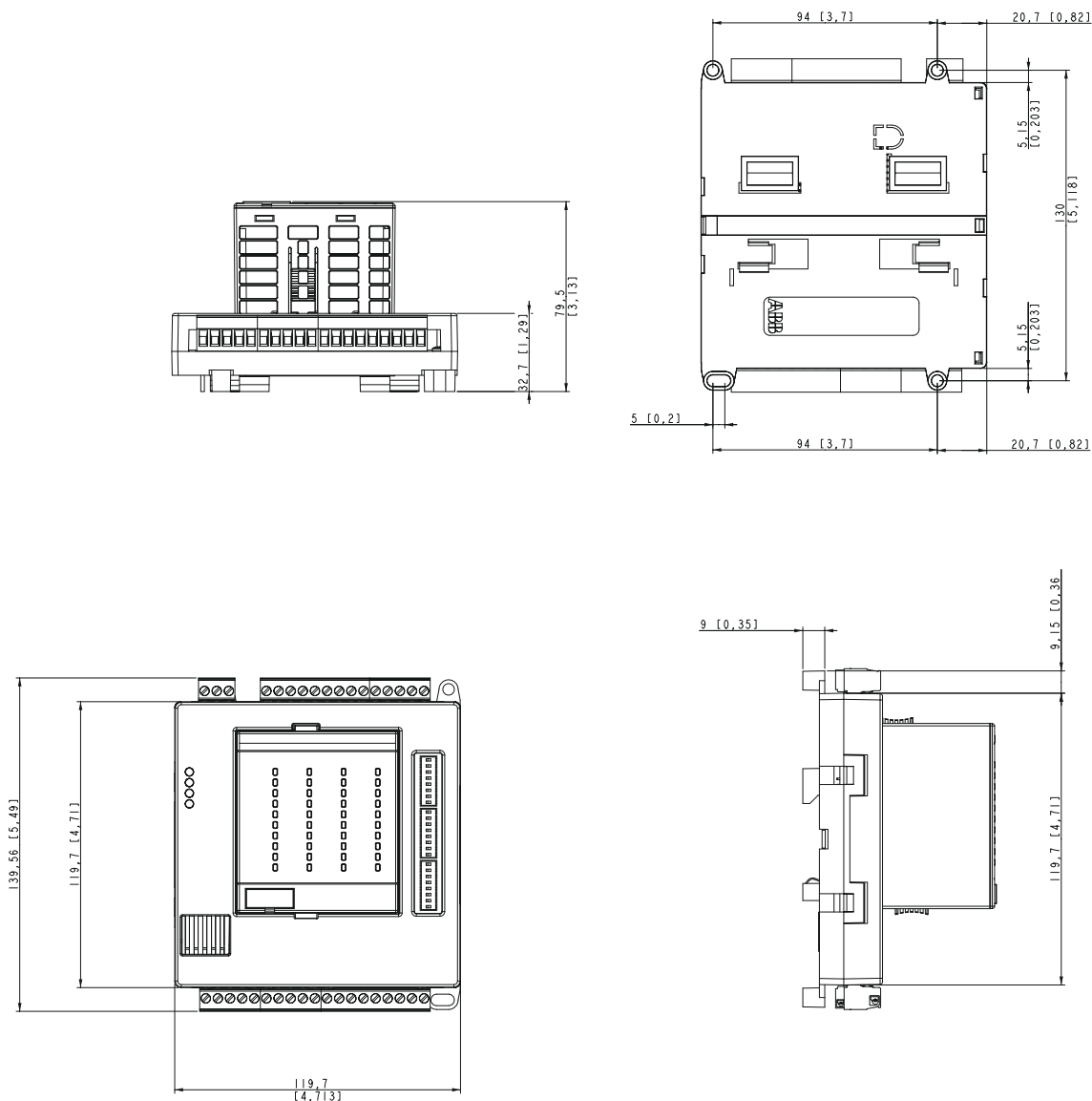

 *The dimensions are in mm and in brackets in inch.*



The dimensions for the assembly holes are the same for the replacement device and the existing device.

To assemble or disassemble the replacement device, grab the device at the housing and not directly at the S500 module.

Ordering data

Order No.	Scope of delivery
1SAP 800 100 R0010	Analog input/output module 07AC91-AD2 1 2-pole terminal block (3.81 mm grid space) 1 3-pole terminal block (5.08 mm grid space) 1 5-pole terminal block (5.08 mm grid space) 4 8-pole terminal blocks (3.81 mm grid space)

1.5.3 Replacement device 07AI91-AD

1.5.3.1 Introduction

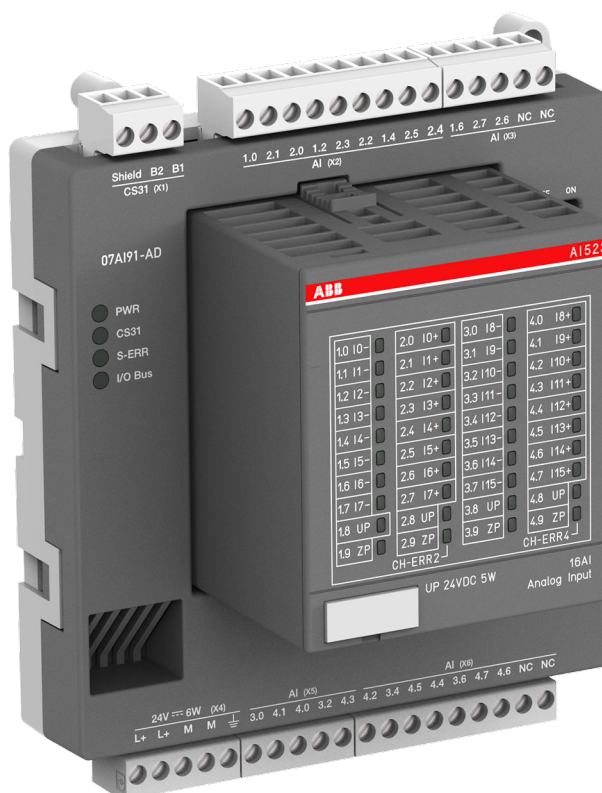

Fig. 40: 3ADR331191S0015_07AI91-AD

The replacement device 07AI91-AD from the AC31 adapter series replaces the existing device 07DC91 from the 90 series.

During the development of the replacement device, care was taken to keep the device configuration identical to the configuration of the existing device. Thus, the existing documentation of device 07AI91 remains valid and serves as a reference (*system description Advant Controller 31*). The document structure of this document is based on the document structure of the existing documentation.

This document adds the following points to the still valid existing documentation:

- Unavoidable device deviations, e.g. due to technical limitations.
- Expansion of documentation as a result of normative requirements.
- Additional contents not described in the existing documentation.

Further information on replacement device 07AI91-AD can be found in the operating and assembly instructions of device 07AI91-AD: 3ADR020086M0401. Please note that for the existing device 07AI91 no separate operating and assembly instructions are available.

Please also observe the system data as well as the information on CS31 bus *Chapter 1.3 "System data and CS31 bus system data" on page 4.*

1.5.3.2 Device configuration

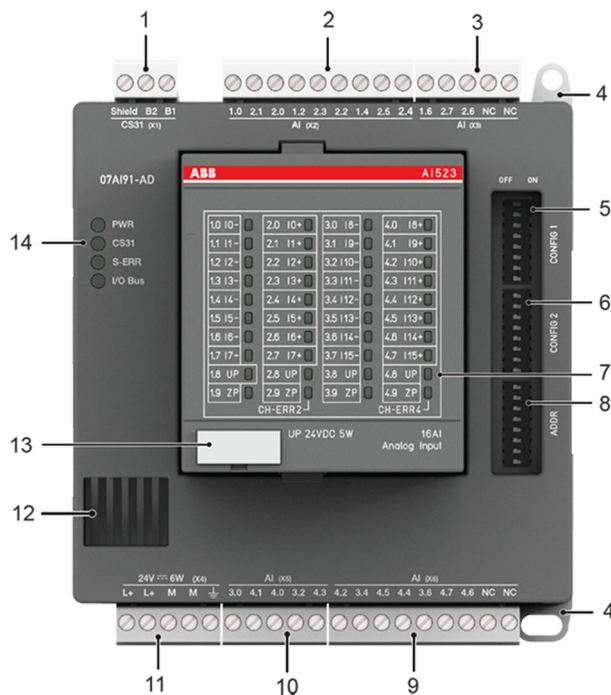

- 1 Connection for CS31 bus (X1)
- 2 Analog inputs (X2). 2.5 AI (± 10 V differential, ± 5 V differential, temperature measurement PT100 / PT1000, 4...20 mA and 0...20 mA with external resistor)
- 3 Analog inputs (X3). 1.5 AI (± 10 V differential, ± 5 V differential, temperature measurement PT100 / PT1000, 4...20 mA and 0...20 mA with external resistor)
- 4 Hole for screw mounting (screw diameter 4 mm, extension torque 1.2 Nm)
- 5 DIP switch for CONFIG1
- 6 DIP switch for CONFIG2
- 7 Status LEDs for AI523
- 8 DIP switch for ADDR
- 9 Analog inputs (X6). 2.5 AI (± 10 V differential, ± 5 V differential, temperature measurement PT100 / PT1000, 4...20 mA and 0...20 mA with external resistor)
- 10 Analog inputs (X5). 1.5 AI (± 10 V differential, ± 5 V differential, temperature measurement PT100 / PT1000, 4...20 mA and 0...20 mA with external resistor)

- 11 Supply 24 V DC (incl. AI523)
- 12 Ventilation
- 13 TA525: Label
- 14 4 Status LEDs of complete device

 *In contrast to the existing device, the following measuring ranges are not available in the replacement device: ± 500 mV, ± 50 mV. Temperature measurement with thermocouples is also not possible.*

The replacement device does not perform a self-calibration.

1.5.3.2.1 LED display

The LED display on the replacement device is changed:

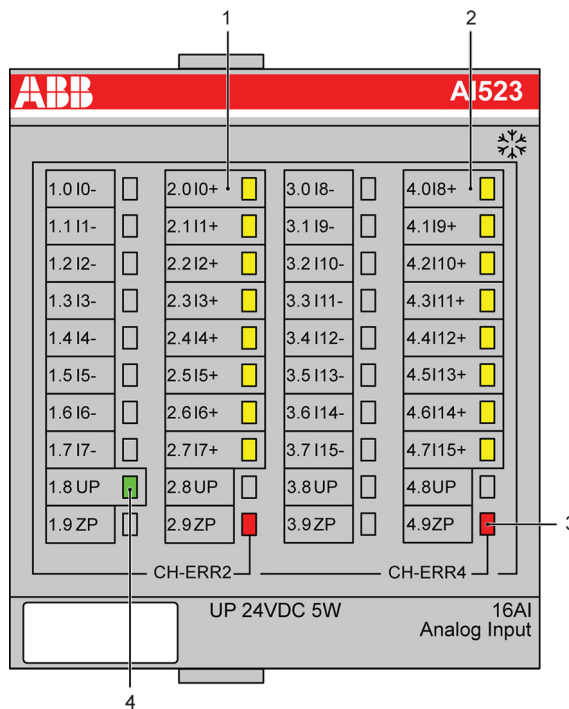



Fig. 41: Front view: 07A191-AD

No.	Display of module
1	8 yellow LEDs to indicate the signal states of the analog inputs (X2 and X3)
2	8 yellow LEDs to indicate the signal states of the analog inputs (X5 and X6)
3	2 red LEDs to indicate errors (of AI523 module)
4	1 green LED to indicated the status of the supply voltage of the AI523 module (is supplied via X4)

 *The replacement device does not provide a test button to measure functionality.*

1.5.3.2.2 Connections

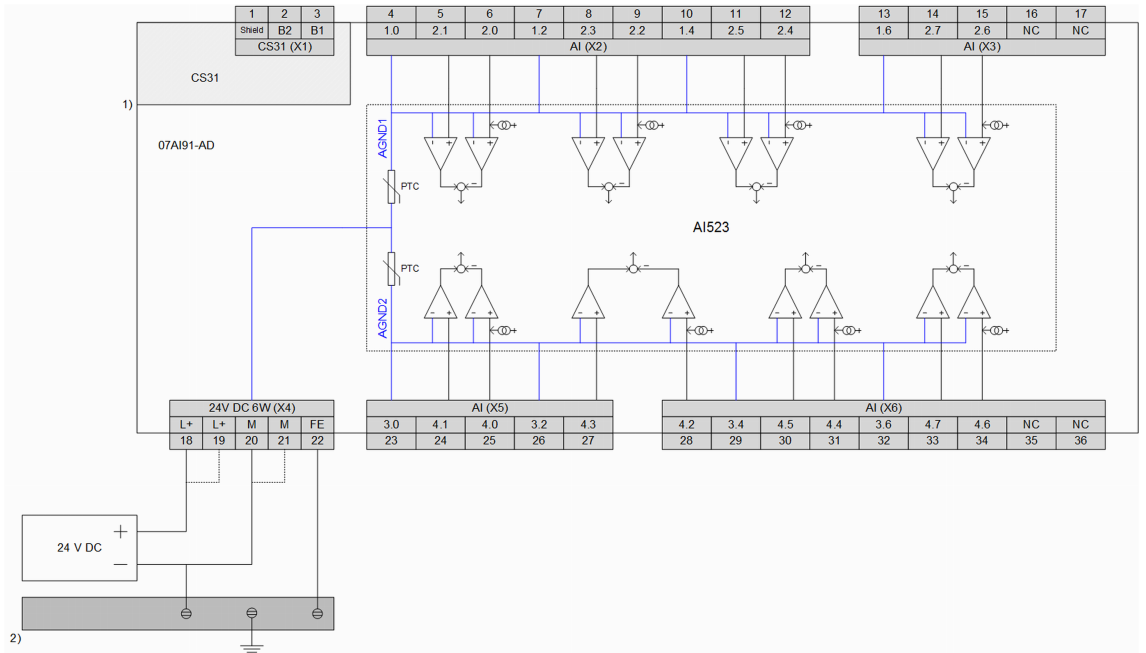

Fig. 42: Connection

- 1) Galvanic isolation
- 2) Switchgear cabinet grounding

Please observe the following information:

- The **Shield** connections of the CS31 bus and **FE** of the supply voltage have no connection within the device.
- The process voltage must be included in the grounding concept of the control system (e.g. grounding of the negative pole).
- The connections of all sensors must be galvanically isolated from the mounting environment of the sensors. The cable shields of the temperature sensors are grounded to the switchgear cabinet at the entry into the cabinet. The setting of the module address as well as the configuration of the analog channels are performed by means of DIP switches (see next pages).
- Unused inputs must be configured as "not evaluated" (DIP switch).
- The current sources in AI523 are configurable and therefore not always active. The current sources are connected alternately with the multiplex method. Consequently, the device does not have 8 current sources.
- The module address and the analog channels are set with DIP switches.

Table 51: Pin assignment CS31 bus (X1)

Connector / Terminal	Pin	Assignment / Signal
X1 / Shield	1	No internal connection
X1 / B2	2	BUS 2
X1 / B1	3	BUS 1

Table 52: Pin assignment AI (X2)

Connector / Terminal	Pin	Assignment / Signal
X2 / 1.0	4	AI523 / I0- (AGND1)
X2 / 2.1	5	AI523 / I1+
X2 / 2.0	6	AI523 / I0+

Connector / Terminal	Pin	Assignment / Signal
X2 / 1.2	7	AI523 / I2- (AGND1)
X2 / 2.3	8	AI523 / I3+
X2 / 2.2	9	AI523 / I2+
X2 / 1.4	10	AI523 / I4- (AGND1)
X2 / 2.5	11	AI523 / I5+
X2 / 2.4	12	AI523 / I4+

Table 53: Pin assignment AI (X3)

Connector / Terminal	Pin	Assignment / Signal
X3 / 1.6	13	AI523 / I6- (AGND1)
X3 / 2.7	14	AI523 / I7+
X3 / 2.6	15	AI523 / I6+
X3 / NC	16	Not connected
X3 / NC	17	Not connected

In module AI523, the signals I0-, I2-, I4- and I6- are internally connected to an analog ground. The potential difference of the analog ground to M is ± 1 V (max.). The replacement device has no current sources on pins 16 and 17. If necessary, these current sources can be connected to individual measurement channels via the configuration (DIP switch).

Table 54: Pin assignment 24 V DC 6W (X4)

Connector / Terminal	Pin	Assignment / Signal
X4 / L+	18	L+
X4 / L+	19	L+
X4 / M	20	M
X4 / M	21	M
X4 / FE	22	FE

Table 55: Pin assignment AI (X5)

Connector / Terminal	Pin	Assignment / Signal
X5 / 3.0	23	AI523 / I8- (AGND2)
X5 / 4.1	24	AI523 / I9+
X5 / 4.0	25	AI523 / I8+
X5 / 3.2	26	AI523 / I10- (AGND2)
X5 / 4.3	27	AI523 / I11+

Table 56: Pin assignment AI (X6)

Connector / Terminal	Pin	Assignment / Signal
X6 / 4.2	28	AI523 / I10+
X6 / 3.4	29	AI523 / I12- (AGND2)
X6 / 4.5	30	AI523 / I13+
X6 / 4.4	31	AI523 / I12+
X6 / 3.6	32	AI523 / I14- (AGND2)
X6 / 4.7	33	AI523 / I15+
X6 / 4.6	34	AI523 / I14+

Connector / Terminal	Pin	Assignment / Signal
X6 / NC	35	Not connected
X6 / NC	36	Not connected

In module AI523, the signals I8-, I10-, I12- and I14- are internally connected to an analog ground. The potential difference of the analog ground to M is ± 1 V (max.). The replacement device does not have current sources on pins 35 and 36. If necessary, these current sources can be connected to individual measurement channels via the configuration (DIP switch).



CAUTION!
System damage caused by voltage!
 The exchange of a replacement device under voltage can cause permanent system damage (destruction).

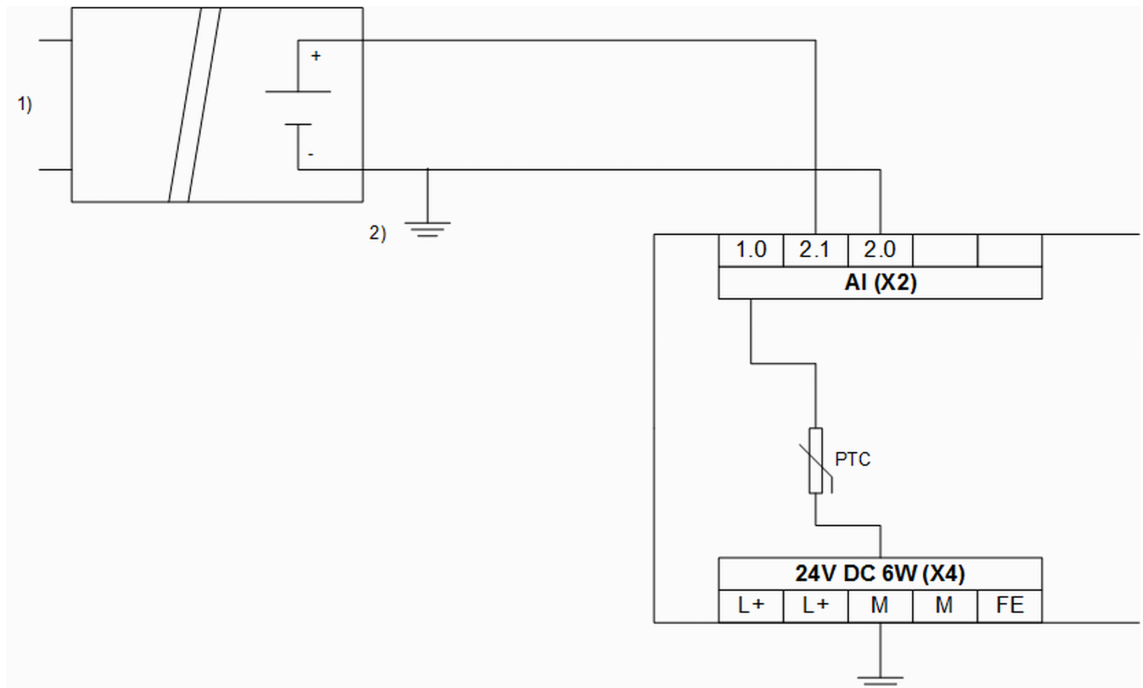



Fig. 43: Differential voltage input

- 1) Galvanically isolated power supply of analog sensor
- 2) Grounding at sensor
 ± 10 V or ± 5 V at differential inputs

On the replacement devices, the wire-break detection is also active in case of a differential voltage measurement. For this purpose, each measuring channel is internally pulled to "plus" by means of a high-impedance resistor. As a result, the individual potentials of the differential voltage measurement must also be referenced to M. Completely isolated voltages are **not** symmetrized to M by the inputs.



The potential difference of the grounding at the sensor to M must not be too big (max. ± 1 V for the whole signal range). Otherwise problems can occur concerning the common-mode input voltages of the involved analog inputs.



Analog signal lines must be routed in shielded cables. The shield must be grounded on both sides and should be grounded to replacement device and signal source / signal sink as close as possible.

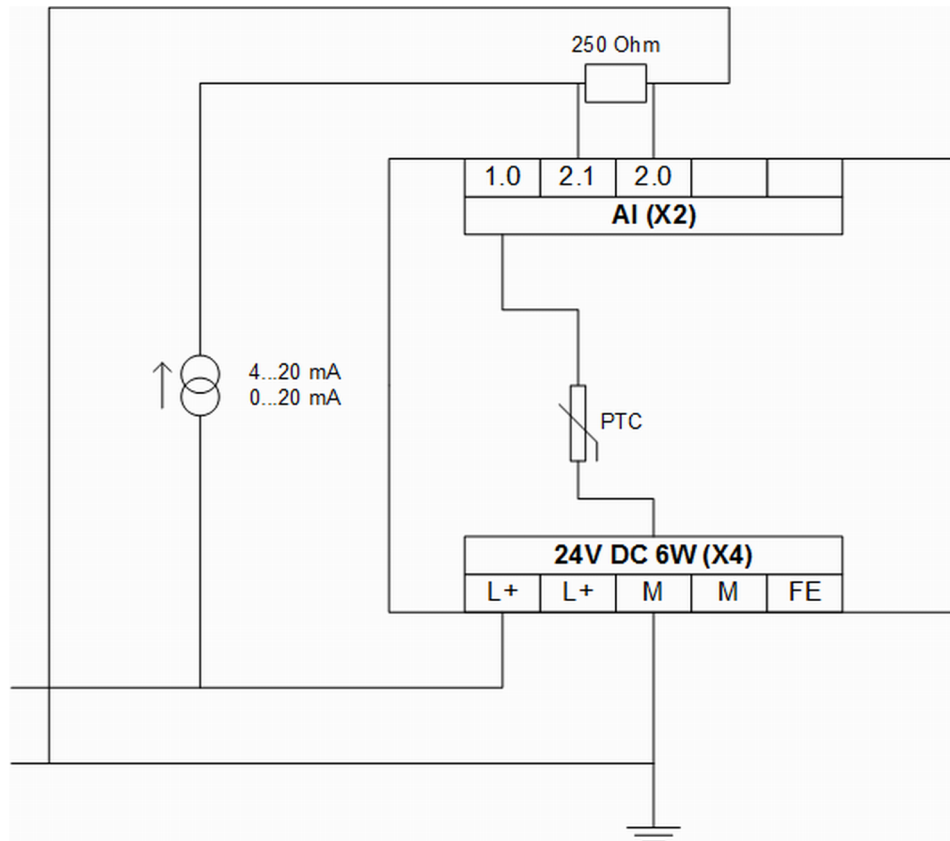

Fig. 44: Current input with external resistor

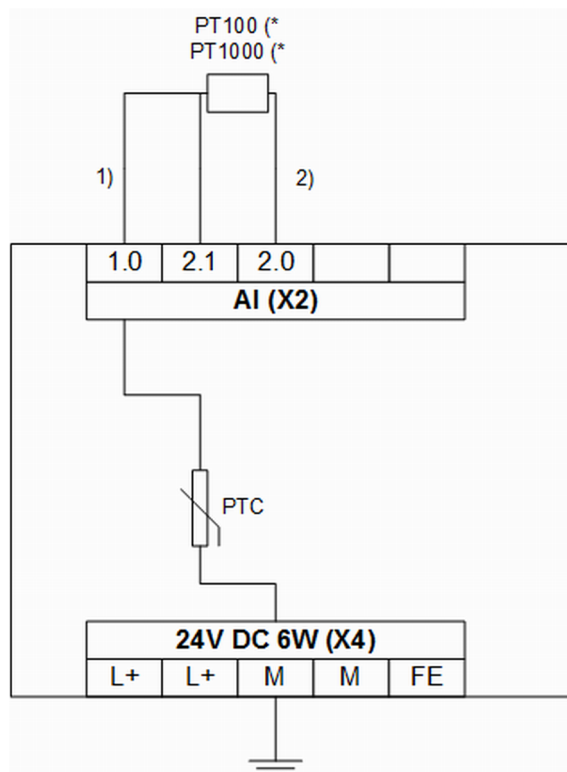

Fig. 45: Resistance thermometer

- 1) Return conductor
- 2) Twisted wire pair in the cable
- (*) 3-wire

For temperature measurements with PT100/PT1000 resistors, the wiring to the existing device must be changed. A 4-wire temperature measurement is not possible with the replacement device. Based on the above figure, a 3-wire temperature measurement can be implemented.

1.5.3.2.3 Configuration

The existing device had a DIP switch on the upper printed circuit board. Since the replacement device is not equipped with an upper printed circuit board, the white DIP switch is arranged on the lower printed circuit board instead.

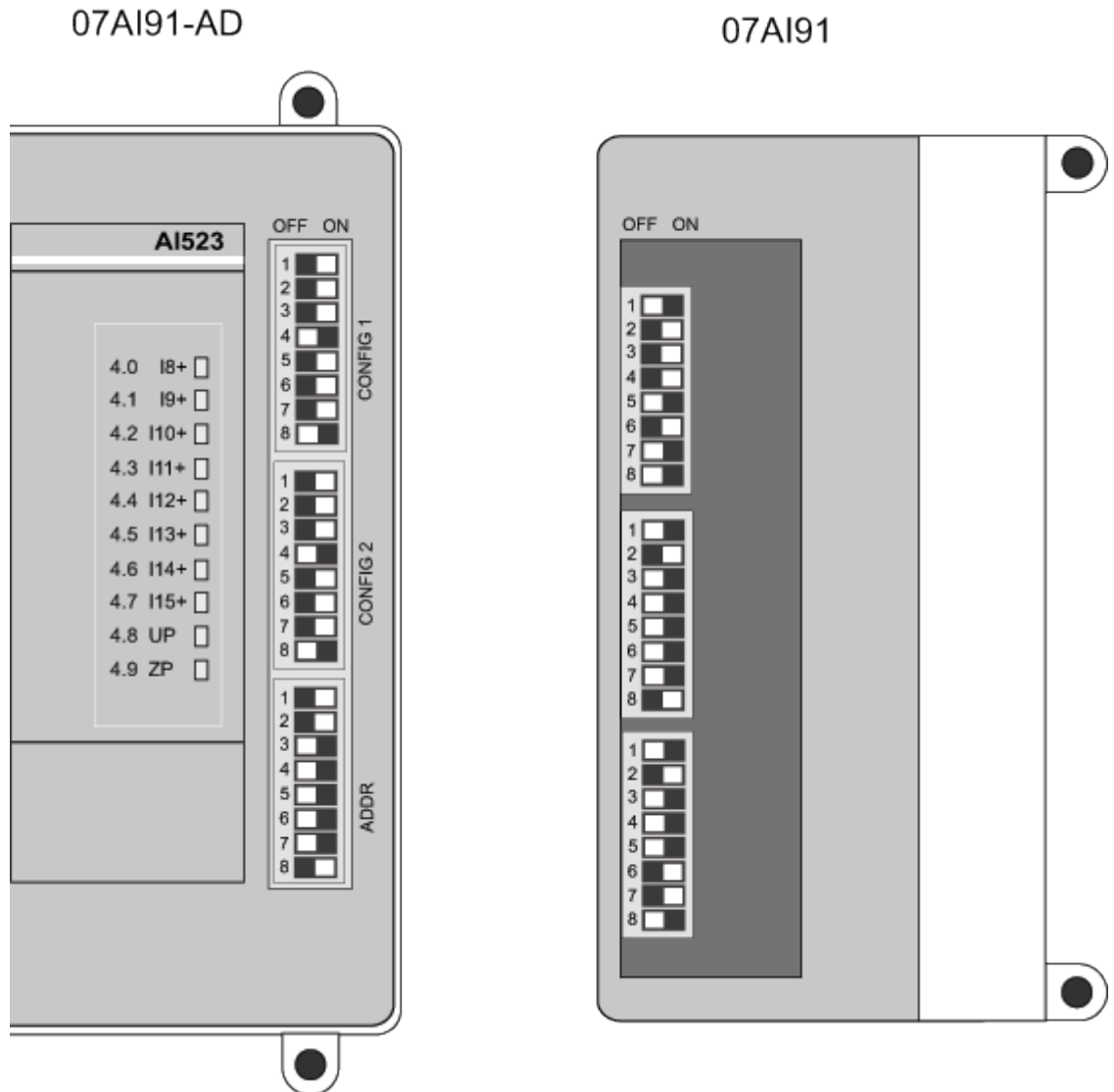

Fig. 46: DIP switch for 07AI91-AD

The function of the address DIP switch 8 (channel No. ≤ 7 or channel No. > 7) is not supported for the replacement device. This DIP switch must be switched off.

On address DIP switch 3 (assignment of analog value), only the CS31 bus format is supported in the replacement device. This DIP switch must be switched on. The setting of the line frequency suppression (address DIP switch 1 and 2) has no effect on the existing device 07AI91.



The following settings of DIP switches CONFIG 1 and CONFIG 2 are not implemented in the replacement device and must not be selected:

- $\pm 500 \text{ mV}$
- $\pm 50 \text{ mV}$
- J-type thermocouple with linearization
- K-type thermocouple with linearization
- S-type thermocouple with linearization



For further information, please refer to the existing documentation System description Advant Controller 31.

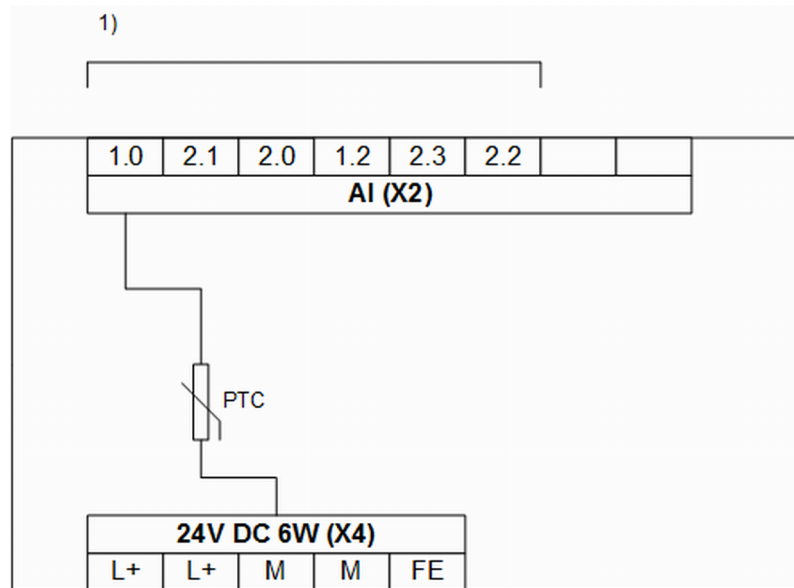

Fig. 47: "Configuration pair" not used

1) Channel 0 and channel 1 are not used -> DIP switch "No evaluation of channels"



If both channels of a "configuration pair" are not used, set the DIP switches to "No evaluation of channels".

The DIP switches are read by the device only once after the supply voltage has been connected.

1.5.3.2.4 Measuring ranges of the input channels

All input signals are not evaluated as differential signals. Two input channels are used to implement a differential measurement.

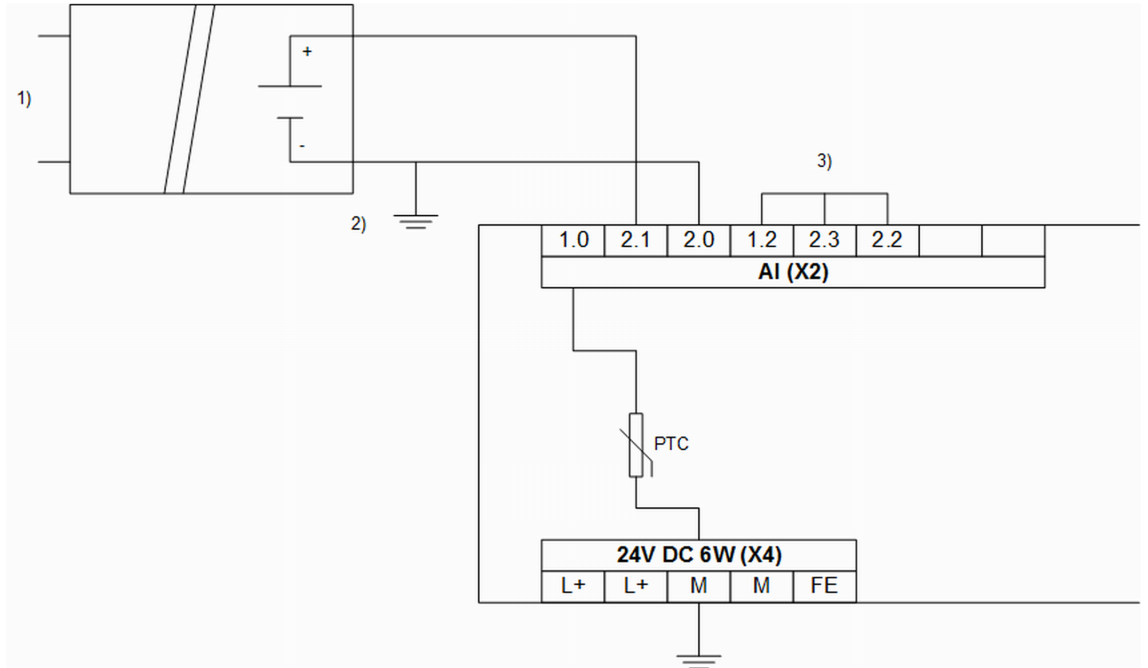

Fig. 48: Only one channel of a "configuration pair" is used

- 1) Galvanically isolated power supply of analog sensor
- 2) Grounding at sensor
- 3) Channel not used
 $\pm 10\text{ V}, \pm 5\text{ V}$ at differential inputs

i If only one channel of a "configuration pair" is used (e.g. channel 0 and 1), then the other channel must be short-circuited during a voltage measurement. Short-circuited in this context means that for instance the connections 1.2, 2.3 and 2.2 are connected. Otherwise the channel not used reports that the range has been exceeded.

Measuring ranges

- Measuring ranges $\pm 10\text{ V} / \pm 5\text{ V} / \pm 500\text{ mV}$ and $\pm 50\text{ mV}$ no longer exist.
- Measuring ranges $4 \dots 20\text{ mA} / 0 \dots 20\text{ mA}$ not changed to existing documentation.

Pt 100 / Pt 1000

To measure the temperature by means of resistors, a constant current is supplied by the replacement device. This imprint no longer occurs at terminals 16, 17, 35 and 36. Therefore the wiring must be changed for the temperature measurement.

Further information:

- Fig. 42
- Fig. 45
- Figures 5.2-4 and 5.2-5 from the existing documentation of the 07AI91 are not valid for the replacement device *System description Advant Controller 31*.
- Terminals 7, 10, 13, 26, 29 and 32 can no longer be used as connection bases. The terminals are only used for the 3-wire temperature measurement *System description Advant Controller 31*.

i **Wire-breakage**
 In case of a wire-breakage, the numerical value +32767 is output. This is followed by an error message via the CS31 bus.



Channel use

If only one channel of a "configuration pair" is used (e.g. channel 0 and 1), then the other channel must be connected with a resistor (e.g. 120 Ω Pt100 measuring range, 1200 Ω Pt1000 measuring range). Otherwise an error message is indicated.



NOTICE!

Temperature-dependent resistors

Other temperature-dependent resistors cannot be used for the replacement device.



NOTICE!

Thermocouples type J, type K, type S

Thermocouples cannot be evaluated with the replacement device. The respective section in the existing documentation (incl. figure 5.2-6) is not valid for device 07A191.



Configuration for unused channels

See existing documentation 07A191 [System description Advant Controller 31](#).



Relationship between the measuring values and the location of the bits in a 16 bit WORD

- *The measuring ranges ± 500 mV and ± 50 mV no longer exist.*
- *Measuring range ± 5 V:*
 - *Replacement device: 11 bit resolution plus sign*
 - *Existing device: 12 bit resolution plus sign*
- *All measuring ranges for thermocouples are no longer available.*

1.5.3.2.5 Addressing

In the following, the information in the "Type" column refers to the data type designation of the Automation Builder (see AC31 system data [Chapter 1.3 "System data and CS31 bus system data" on page 4](#)). The information in the "Type" column must be interpreted from the viewpoint of the CS31 bus master. The information in brackets must be interpreted from the viewpoint of the replacement device (CS31 bus slave).



The function of the address DIP switch 8 (channel No. ≤ 7 or channel No. > 7) is no longer supported.

Table 57: CS31 bus

Type	Byte	Connector / Terminal
WORD input (send) 0	1	X2 / 2.1, X2 / 2.0
	2	
WORD input (send) 1	3	X2 / 2.3, X2 / 2.2
	4	
WORD input (send) 2	5	X2 / 2.5, X2 / 2.4
	6	
WORD input (send) 3	7	X3 / 2.7, X3 / 2.6
	8	
WORD input (send) 4	9	X5 / 4.1, X5 / 4.0
	10	
WORD input (send) 5	11	X5 / 4.3, X6 / 4.2
	12	
WORD input (send) 6	13	X6 / 4.5, X6 / 4.4
	14	
WORD input (send) 7	15	X6 / 4.7, X6 / 4.6
	16	



When the measuring values are bipolar, use data type "INT input" instead of "WORD input".

1.5.3.2.6 Behavior during normal operation

Interpretation of the LEDs:

- The device initializes automatically after the supply voltage is switched on. During this time, the S-ERR LED flashes.
- The PWR LED lights up as soon as the internal supply voltage of the device is present.
- After successful initialization of the I/O bus communication to the S500 module, the I/O bus LED lights up.
- After successful initialization of the CS31 bus communication, the CS31 bus LED lights up. The S-ERR LED goes out.
- During operation, the yellow LEDs indicate the signal states of the channels.

The RAM is checked during the initialization of the device. In addition, the firmware in the flash memory is checked by means of a checksum during initialization. When the control system (PLC/central unit) is stopped during normal operation, the inputs remain active.

1.5.3.2.7 Diagnosis and display

LEDs are used for diagnosis and display purposes. In addition, some diagnosis information can be transmitted via the CS31 bus.



 *The replacement device does not provide a test button to measure functionality.*

Table 58: Diagnosis information of the CS31 bus

Channel	Error code (CODESYS)	Error code (CS31 bus bus)	Description
Device error:			
0	43	1	Internal error
Channel error:			
0 ... 7	45	9	Cut wire (is also indicated if the current in measuring range 4 ... 20 mA is less than 2 mA)
0 ... 7	49	10	Analog value is out of measuring range

 *The error codes that are transferred by the replacement device via the CS31 bus bus are newly displayed in CODESYS. Each error code of the CS31 bus (table column 3) produces the error code in CODESYS (table column 2). As a result, it is possible to operate the replacement device with a new control system (PLC/control unit), e.g. 07KT98-ARC-AD, as well as with an old control system (PLC/central unit), e.g. 07KT98.*



 *An exceedance of the measuring range is signaled even if nothing is connected to an analog voltage input.*

Table 59: Device LEDs

LED	Status	Color	LED off	LED on	LED flashes
PWR	Voltage supply	Green	No internal supply voltage	Internal supply voltage	-
CS31 bus	CS31 bus communication	Green	No CS31 bus communication	CS31 bus communication	Only diagnosis, no data transfer. Transmission is disturbed.
S-ERR	Error	Red	No error	Static error (must be confirmed by the control system)	No CS31 bus connection or activity
I/O bus	I/O bus communication	Green	No I/O bus communication	I/O bus communication	Error I/O bus communication

The S-ERR LED remains on even if the error no longer occurs. The error must be confirmed by the control system (PLC/central unit), e.g. by means of a function block  Chapter 1.3 “System data and CS31 bus system data” on page 4.

Special cases with rapidly flashing LEDs (approx. 5 Hz):

- All 4 LEDs flash rapidly: An incorrect S500 module is connected to the device. The device fails to initialize.
- The LEDs of the CS31 bus, S-ERR bus and I/O bus flash rapidly: Invalid position of DIP switches. The device fails to initialize.
- The LEDs of the S-ERR bus and I/O bus flash rapidly: A checksum error occurred in an internal flash memory.
- The LED of the I/O bus flashes rapidly: An error occurred in an internal RAM.

Table 60: LEDs of the S500 module AI523

LED	Status	Color	LED off	LED on	LED flashes
I1+, I3+, I5+, I7+ (see No. 1 in the following figure)	Analog inputs	Yellow	Input is not activated	Input is activated (brightness depends on value of analog signal).	-
I9+, I11+, I13+, I15+ (see no. 2 in the following figure)	Analog inputs	Yellow	Input is not activated	Input is activated (brightness depends on value of analog signal).	-
Error indication left (see No. 3 in the following figure)	Error indication	Red	No error	Internal error	Cut wire on a channel of the corresponding group
Error indication right (see No. 3 in the following figure)	Error indication	Red	No error	Internal error	Cut wire on a channel of the corresponding group
Indication supply voltage (see No. 4 in the following figure)	Process voltage	Green	Process voltage not available	Process voltage OK	-

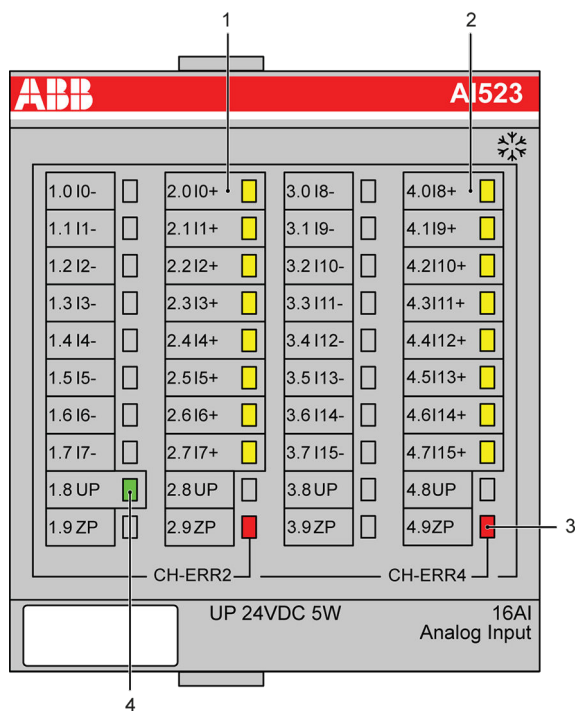

Fig. 49: 07AI91-AD_Front

1.5.3.2.8 Technical data

This section provides additional information on section [Chapter 1.3 “System data and CS31 bus system data”](#) on page 4. In case of doubt, the following information applies.

Technical data of the complete device

Data	Value
Process voltage:	
-> Connections	X4/L+ (pin 18), X4/L+ (pin 19), X4/M (pin 20), X4/M (pin 21)
-> Fuse for L+	10 A, fast acting
- Galvanic isolation	No
Current consumption:	
-> via L+	0.19 A
- Inrush current via L+ (when voltage is switched on)	0.22 A ² s
Power consumption	Replacement device: 6 W Existing device: 3 W
Address setting and configuration	DIP switch right side of housing
Max. line length of analog lines, line cross section > 0.14 mm ²	100 m



For further information, please refer to the existing documentation [System description Advant Controller 31](#).



CAUTION!
System damage caused by voltage!

Exceeding the maximum supply or process voltage (>30 V DC) results in permanent system damage (destruction).

Technical data of the analog inputs

Data	Value
Connections	[X2 / 2.1, X2 / 2.0], [X2 / 2.3, X2 / 2.2], [X2 / 2.5, X2 / 2.4], [X3 / 2.7, X3 / 2.6], [X5 / 4.1, X5 / 4.0], [X5 / 4.3, X6 / 4.2], [X6 / 4.5, X6 / 4.4], [X6 / 4.7, X6 / 4.6]
Reference connections (AGND1)	X2 / 1.0, X2 / 1.2, X2 / 1.4, X3 / 1.6
Reference connections (AGND2)	X5 / 3.0, X5 / 3.2, X6 / 3.4, X6 / 3.6
Max. potential difference AGND1/2 <-> M	± 1 V
Type of inputs	Voltage bipolar, current unipolar, temperature measurement
Line frequency suppression	Not available
Time constant of the input filter	Replacement device: Voltage: 100 µs, current 100 µs Existing device: no RC combination available
Conversion cycle	Replacement device: 2 ms over 8 inputs, 1 s during temperature measurement Existing device: 30 ms to 150 ms, depending on configuration
Protection against reversed voltage	Yes
Overvoltage protection	Up to 30 V DC



For further information, please refer to the existing documentation [System description Advant Controller 31](#).

Analog voltage input

Data	Value
Input resistance	Replacement device: > 100 kΩ Existing device: > 1 MΩ
Measuring ranges nominal values	Replacement device: ± 10 V, ± 5 V Existing device: ± 10 V, ± 5 V, ± 500 mV, ± 50 mV

Data	Value
Resolution	12 bit + sign (measuring range ± 10 V) 11 bit + sign (measuring range ± 5 V)
Total error	Replacement device: ± 1 % of full range value Existing device: ± 0.5 % of full range value
Common mode input voltage range (e.g. X2 / 2.1, reference e.g. X2 / 1.0 (AGND1))	-10 V ... +10 V



For further information, please refer to the existing documentation [System description Advant Controller 31](#).

Current input 0 ... 20 mA / 4 ... 20 mA

Total error:

Replacement device: ± 1 % of full range value \pm tolerance of current-sensing resistor

Existing device: ± 0.5 % of full range value + tolerance of current-sensing resistor

Pt100/Pt1000 input

Data	Value
Measurement method	Replacement device: 3-wire configuration Existing device: 4-wire configuration. It is no longer possible to connect sensors in series.
Evaluation errors in measuring range -50... +400 °C	Replacement device: ± 1 % of full range value Existing device: ± 0.5 % of full range value at Pt100, ± 1 % of full range value at Pt1000
Current source for Pt100/Pt1000 resistors	The replacement device has a constant current source that is alternately connected to up to 8 analog channels (depending on configuration).

Unused input channels

See existing documentation 07AI91.

Connection of other temperature-dependent resistors

Other temperature-dependent resistors cannot be used in the replacement device.

Input with thermocouples

Thermocouples cannot be used in the replacement device. The existing documentation is no longer valid.

Connection to the CS31 bus

Data	Value
Connections	X1 / B2, X1 / B1
CS31 bus type	01 (analog input)
Terminating resistor	Not available (must be provided externally if needed)

Mechanical data

Data	Value
Width x height x depth	Replacement device: 120 x 140 x approx. 80 mm Existing device: 120 x 140 x 85 mm
Weight	Replacement device: 384 g Existing device: 450 g
Dimensions for mounting	See operating and assembly instructions of the replacement device (3ADR020086M0401)

Mounting information

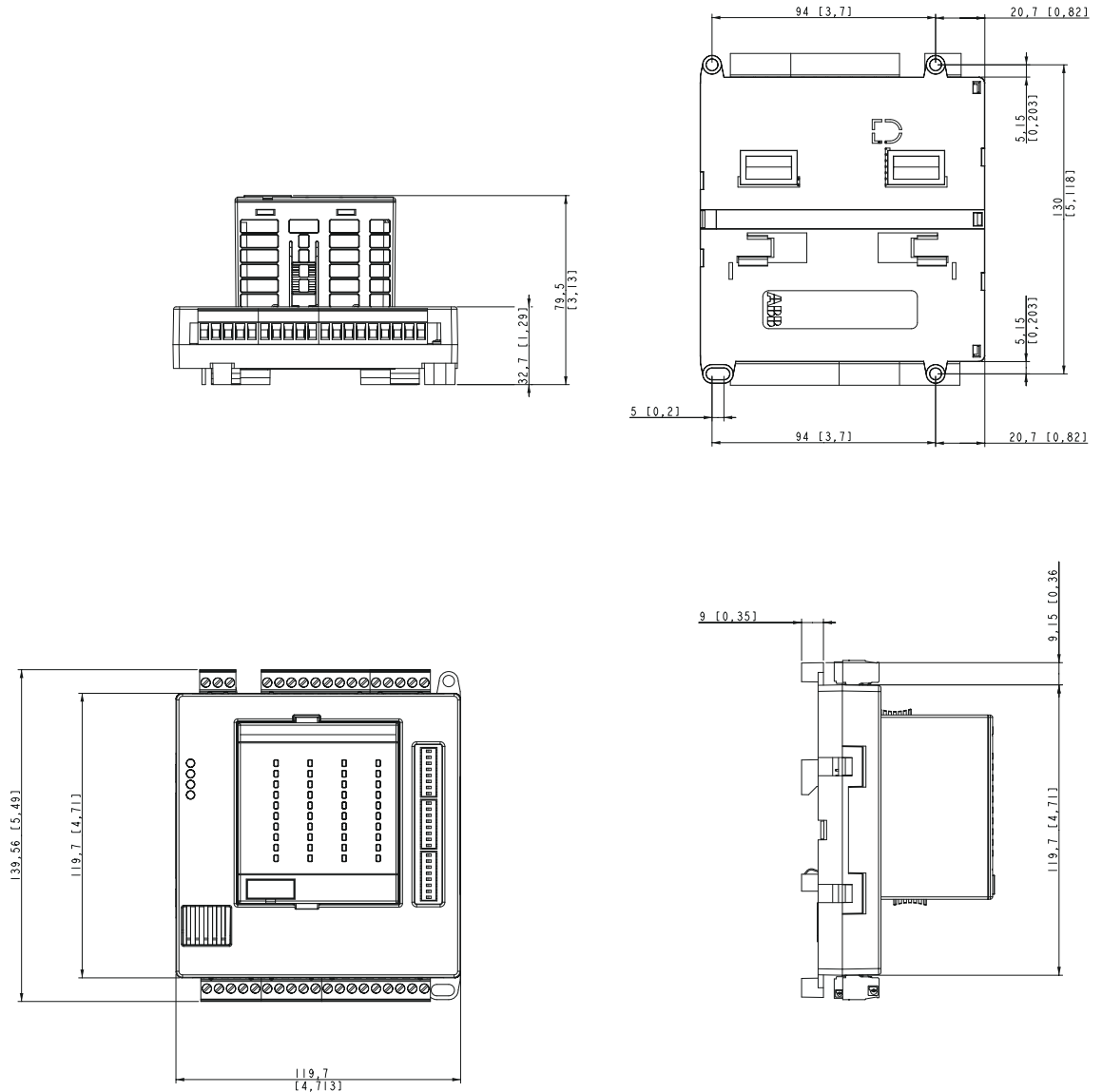

The dimensions are in mm and in brackets in inch.



The dimensions for the assembly holes are the same for the replacement device and the existing device.

To assemble or disassemble the replacement device, grab the device at the housing and not directly at the S500 module.

Ordering data

Order No.	Scope of delivery
1SAP 800 200 R0010	Analog input module 07AI91-AD 1 3-pole terminal block 3 5-pole terminal blocks 2 9-pole terminal blocks

1.5.4 Replacement device 07DC91-AD

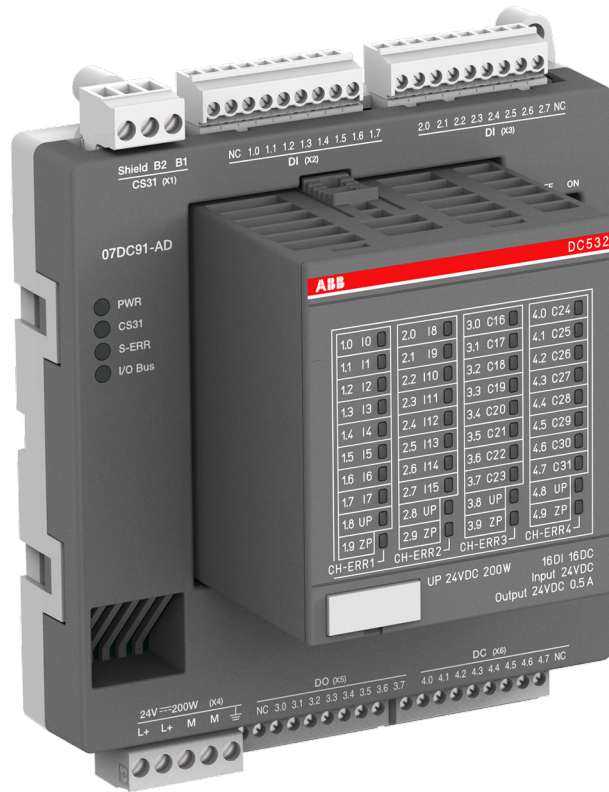

Fig. 50: 3ADR331192S0015_07DC91-AD

The replacement device 07DC91-AD of the AC31 adapter series replaces the existing device 07DC91 of the 90 series.

During the development of the replacement device, care was taken to keep the device configuration identical to the configuration of the existing device. Thus, the existing documentation of device 07DC91 remains valid and serves as reference (*system description Advant Controller 31*). The document structure of this document is based on the document structure of the existing documentation.

This document adds the following points to the still valid existing documentation:

- Unavoidable device deviations, e.g. due to technical limitations.
- Expansion of documentation as a result of normative requirements.
- Additional contents not described in the existing documentation.

Further information on replacement devices 07DC91-AD can be found in the operating and assembly instructions of device 07DC91-AD: 3ADR020083M0401. Please note that for device 07DC91 no separate operating and assembly instructions are available.

Please also observe the system data as well as the information on CS31 bus [Chapter 1.3](#) "System data and CS31 bus system data" on page 4.

1.5.4.1 Device configuration

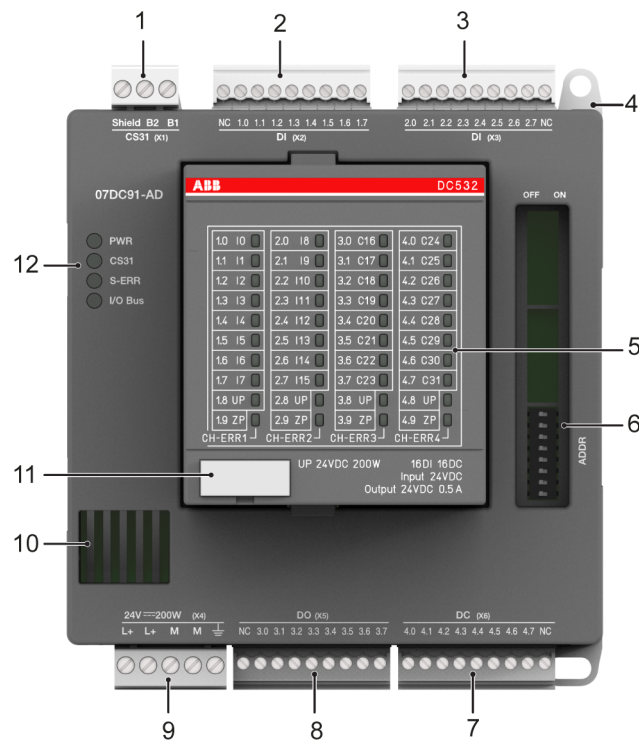

- 1 Connection for CS31 bus (X1)
- 2 8 digital inputs 24 V DC (X2)
- 3 8 digital inputs 24 V DC (X3)
- 4 Hole for screw mounting (screw diameter 4 mm, extension torque 1.2 Nm)
- 5 Status LEDs for DC532
- 6 DIP switch for address setting (ADDR)
- 7 8 digital inputs/outputs 24 V DC / 0.5 A (X6)
- 8 8 digital outputs (X5)
- 9 Supply 24 V DC (X4)
- 10 Ventilation
- 11 TA525: Label
- 12 4 Status LEDs

1.5.4.2 LED display

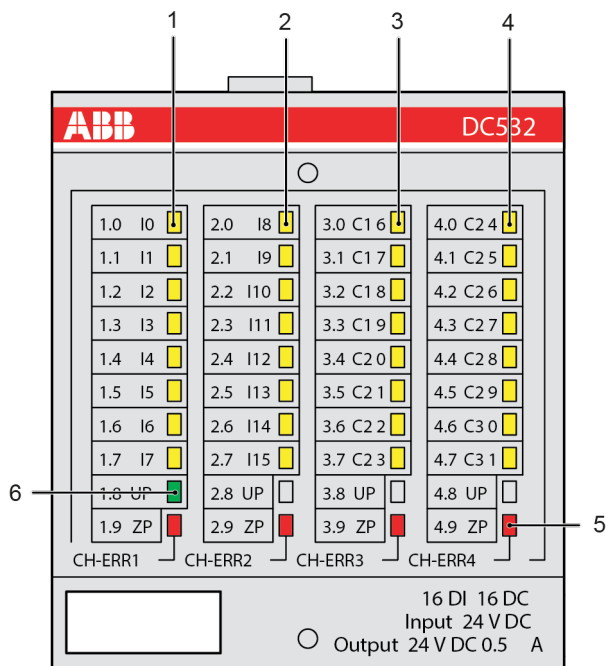

Fig. 51: Front view: DC532

No.	Displays of module
1	8 yellow LEDs to indicate the signal states of the digital inputs (X2).
2	8 yellow LEDs to indicate the signal states of the digital inputs (X3).
3	8 yellow LEDs to indicate the signal states of the digital outputs (X5).
4	8 yellow LEDs to indicate the signal states of the digital inputs/outputs (X6).
5	4 red LEDs to indicate errors (of DC532 module).
6	1 green LED to indicated the status of the supply voltage of the DC532 module (is supplied via X4).



The replacement device does not provide a test button to measure functionality.

1.5.4.3 Connections

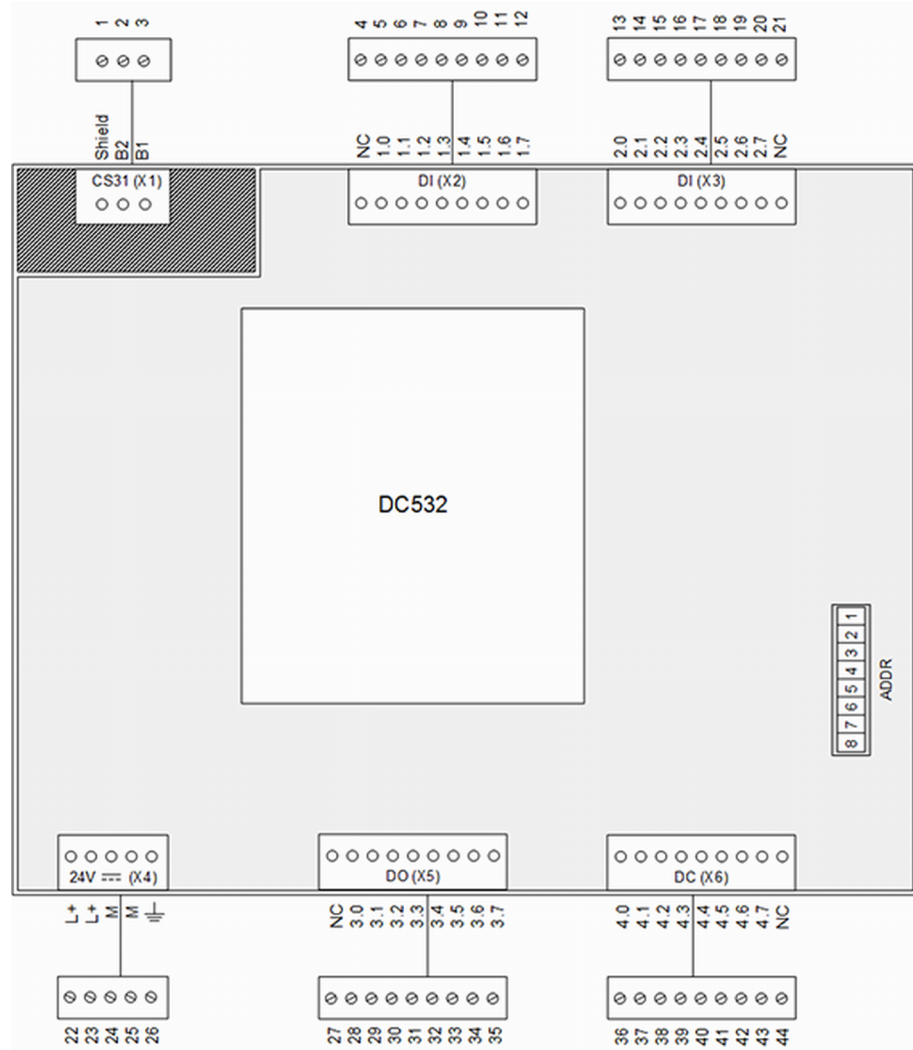

Fig. 52: Connection

Table 61: Pin assignment CS31 bus (X1)

Connector / Terminal	Pin	Assignment / Signal
X1 / Shield	1	No internal connection
X1 / B2	2	BUS 2
X1 / B1	3	BUS 1



The shield connection of the CS31 bus is not galvanically connected to the functional earth of the supply voltage.

Table 62: Pin assignment DI (X2)

Connector / Terminal	Pin	Assignment / Signal
X2 / NC	4	No internal connection
X2 / 1.0	5	DC532 / I0
X2 / 1.1	6	DC532 / I1

Connector / Terminal	Pin	Assignment / Signal
X2 / 1.2	7	DC532 / I2
X2 / 1.3	8	DC532 / I3
X2 / 1.4	9	DC532 / I4
X2 / 1.5	10	DC532 / I5
X2 / 1.6	11	DC532 / I6
X2 / 1.7	12	DC532 / I7

Table 63: Pin assignment DI (X3)

Connector / Terminal	Pin	Assignment / Signal
X3 / 2.0	13	DC532 / I8
X3 / 2.1	14	DC532 / I9
X3 / 2.2	15	DC532 / I10
X3 / 2.3	16	DC532 / I11
X3 / 2.4	17	DC532 / I12
X3 / 2.5	18	DC532 / I13
X3 / 2.6	19	DC532 / I14
X3 / 2.7	20	DC532 / I15
X3 / NC	21	No internal connection

Table 64: Pin assignment DC (X6)

Connector / Terminal	Pin	Assignment / Signal
X6 / 4.0	36	DC532 / C24
X6 / 4.1	37	DC532 / C25
X6 / 4.2	38	DC532 / C26
X6 / 4.3	39	DC532 / C27
X6 / 4.4	40	DC532 / C28
X6 / 4.5	41	DC532 / C29
X6 / 4.6	42	DC532 / C30
X6 / 4.7	43	DC532 / C31
X6 / NC	44	No internal connection

Table 65: Pin assignment DO (X5)

Connector / Terminal	Pin	Assignment / Signal
X5 / NC	27	No internal connection
X5 / 3.0	28	DC532 / C16
X5 / 3.1	29	DC532 / C17
X5 / 3.2	30	DC532 / C18
X5 / 3.3	31	DC532 / C19
X5 / 3.4	32	DC532 / C20
X5 / 3.5	33	DC532 / C21
X5 / 3.6	34	DC532 / C22
X5 / 3.7	35	DC532 / C23

Table 66: Pin assignment 24 V DC 200 W (X4)

Connector / Terminal	Pin	Assignment / Signal
X4 / L+	22	L+
X4 / L+	23	L+
X4 / M	24	M
X4 / M	25	M
X4 / FE	26	FE



The device 07DC91-AD has 16 digital outputs, each with 0.5 A output current. This results in a maximum output current of 8 A. With an output current of 4 A and higher, both terminals (L+) of connector X4 must be used.



CAUTION!

System damage caused by voltage!

The exchange of a replacement device under voltage can cause permanent system damage (destruction).

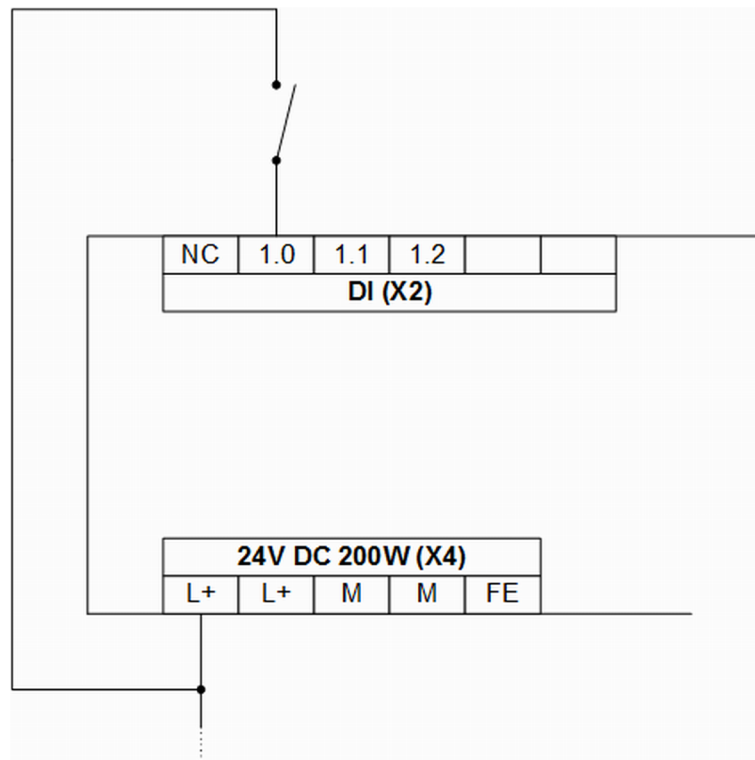

Fig. 53: Connection example: digital input

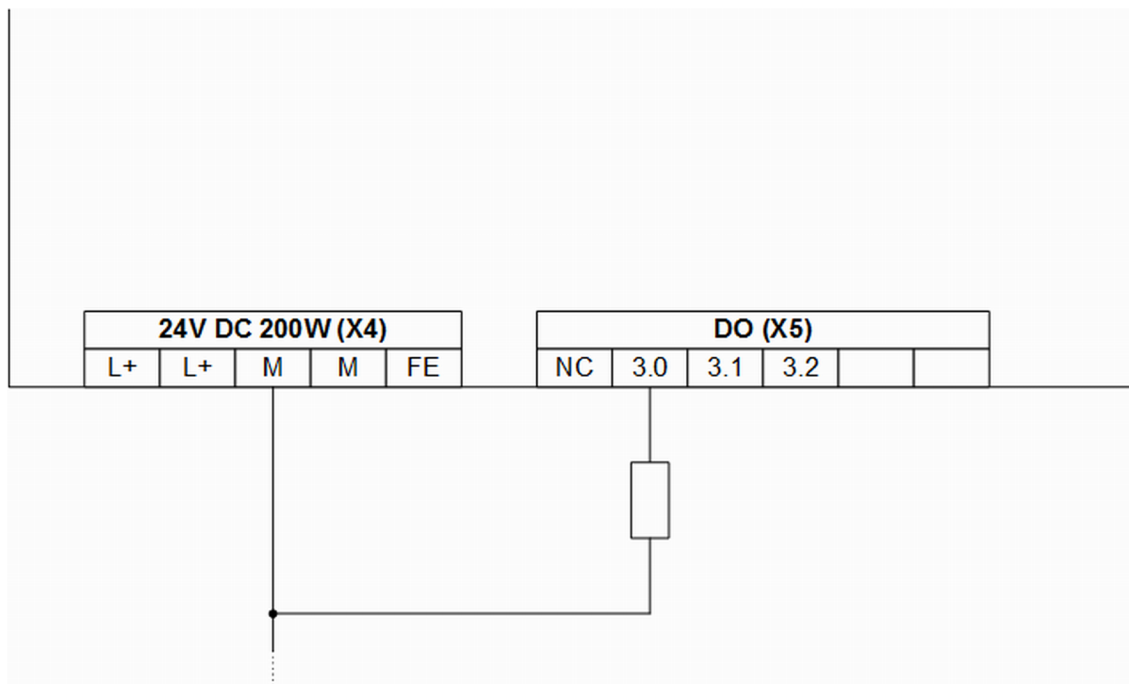

Fig. 54: Connection example: digital output

1.5.4.4 Addressing

In the following, the information in the "Type" column refers to the data type designation of the Automation Builder (see AC31 system data ↗ *Chapter 1.3 "System data and CS31 bus system data" on page 4*). The information in the "Type" column must be interpreted from the viewpoint of the CS31 bus master. The information in brackets must be interpreted from the viewpoint of the replacement device (CS31 bus slave).

Table 67: CS31 bus (16 inputs / 16 outputs)

Byte	Type	Bit	Connector / Terminal
1	8 bit input (send)	0 ... 7	X2 / 1.0
			X2 / 1.1
			X2 / 1.2
			X2 / 1.3
			X2 / 1.4
			X2 / 1.5
			X2 / 1.6
			X2 / 1.7
2	8 bit input (send)	0 ... 7	X3 / 2.0
			X3 / 2.1
			X3 / 2.2
			X3 / 2.3
			X3 / 2.4
			X3 / 2.5
			X3 / 2.6
			X3 / 2.7

Byte	Type	Bit	Connector / Terminal
3	8 bit output (receive)	0 ... 7	X5 / 3.0
			X5 / 3.1
			X5 / 3.2
			X5 / 3.3
			X5 / 3.4
			X5 / 3.5
			X5 / 3.6
			X5 / 3.7
4	8 bit output (receive)	0 ... 7	X6 / 4.0
			X6 / 4.1
			X6 / 4.2
			X6 / 4.3
			X6 / 4.4
			X6 / 4.5
			X6 / 4.6
			X6 / 4.7

Table 68: CS31 bus (24 inputs / 16 outputs)

Byte	Type	Bit	Connector / Terminal
1	8 bit input (send)	0 ... 7	X2 / 1.0 ... 1.7
2	8 bit input (send)	0 ... 7	X3 / 2.0 ... 2.7
3	8 bit output (receive)	0 ... 7	X5 / 3.0 ... 3.7
4	8 bit input (send)	0 ... 7	X6 / 4.0 ... 4.7
5	8 bit output (receive)	0 ... 7	X6 / 4.0 ... 4.7

1.5.4.5 I/O configuration

The existing device had a DIP switch on the upper printed circuit board. Since the replacement device is not equipped with an upper printed circuit board, the white DIP switch is arranged on the lower printed circuit board instead.

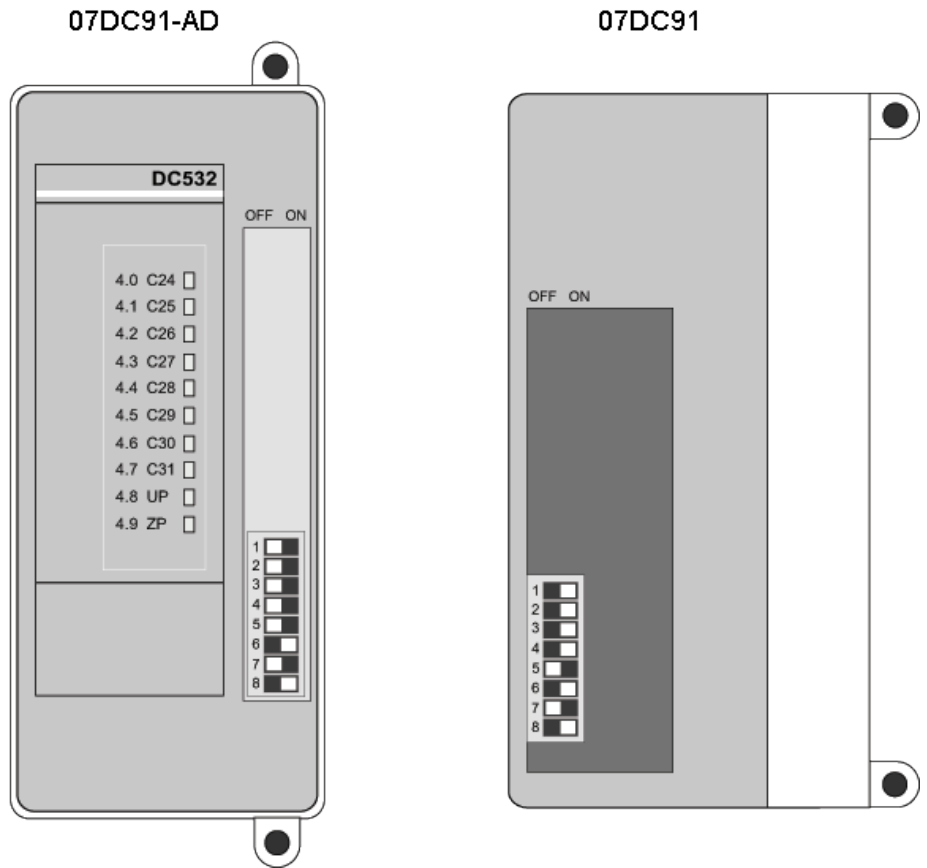

Fig. 55: DIP switch for 07DC91-AD



The DIP switches are read by the device only once after the supply voltage has been connected.



For further information, please refer to the existing documentation System description Advant Controller 31.

1.5.4.6 Behavior during normal operation

Interpretation of the LEDs:

- The device initializes automatically after the supply voltage is switched on. During this time, the S-ERR LED flashes.
- The PWR LED lights up as soon as the internal supply voltage of the device is present.
- After successful initialization of the I/O bus communication to the S500 module, the I/O bus LED lights up.
- After successful initialization of the CS31 bus communication, the CS31 bus LED lights up. The S-ERR LED goes out.
- During operation, the yellow LEDs indicate the signal states of the channels.

The RAM is checked during the initialization of the device. In addition, the firmware in the flash memory is checked by means of a checksum during initialization. When the control system (PLC/central unit) is stopped during normal operation, the outputs of the device 07DC91-AD are switched off. The inputs remain active. The outputs are also switched off in case of a malfunction of the CS31 bus.

1.5.4.7 Diagnosis and displays

LEDs are used for diagnosis and display purposes. In addition, some diagnosis information can be transmitted via the CS31 bus.

 *The replacement device does not provide a test button to measure functionality.*

Table 69: Diagnosis information of the CS31 bus

Error description	Channel	Error code (CODESYS)	Error code (CS31 bus)	Description
Device error	0	43	1	Internal error
Channel error	0, 4, 8, 12 *)	46	4	Overload or short circuit on a digital output

*) The channel numbers are grouped as follows:

- 0 - for X5/3.0, X5/3.1, X5/3.2, X5/3.3
- 4 - for X5/3.4, X5/3.5, X5/3.6, X5/3.7
- 8 - for X6/4.0, X6/4.1, X6/4.2, X6/4.3
- 12 - for X6/4.4, X6/4.5, X6/4.6, X6/4.7

 *The error codes that are transferred by the replacement device via the CS31 bus are newly displayed in CODESYS. Each error code of the CS31 bus (table column 3) produces the error code in CODESYS (table column 2). As a result, it is possible to operate the replacement device with a new control system (PLC/control unit), e.g. 07KT98-ARC-AD, as well as with an old control system (PLC/central unit), e.g. 07KT98.*

Table 70: Device LEDs

LED	Status	Color	LED off	LED on	LED flashes
PWR	Voltage supply	Green	No internal supply voltage	Internal supply voltage	-
CS31 bus	CS31 bus communication	Green	No CS31 bus communication	CS31 bus communication	Only diagnosis, no data transfer. Transmission is disturbed.
S-ERR	Error	Red	No error	Static error (must be confirmed by the control system)	No CS31 bus connection or activity
I/O bus	I/O bus communication	Green	No I/O bus communication	I/O bus communication	Error I/O bus communication

The S-ERR LED remains on even if the error no longer occurs. The error must be confirmed by the control system (PLC/central unit), e.g. by means of a function block ↪ *Chapter 1.3 “System data and CS31 bus system data” on page 4.*

Special cases with rapidly flashing LEDs (approx. 5 Hz):

- All 4 LEDs flash rapidly: An incorrect S500 module is connected to the device. The device fails to initialize.
- The LEDs of the CS31 bus, S-ERR bus and I/O bus flash rapidly: Invalid position of DIP switches. The device fails to initialize.
- The LEDs of the S-ERR bus and I/O bus flash rapidly: A checksum error occurred in an internal flash memory.
- The LED of the I/O bus flashes rapidly: An error occurred in an internal RAM.

Table 71: LEDs of the S500 module DC532

LED	Status	Color	LED off	LED on	LED flashes
I0...I7 (see No. 1 in the following figure)	Digital inputs	Yellow	Input is not activated	Input is activated (input voltage is indicated even if supply is switched off)	-
I8...I15 (see No. 2 in the following figure)	Digital inputs	Yellow	Input is not activated	Input is activated (input voltage is indicated even if supply is switched off)	-
O16...O23 (see No. 3 in the following figure)	Digital outputs	Yellow	Output is not activated	Output is activated	-
O24...O31 (see No. 4 in the following figure)	Digital inputs or digital outputs	Yellow	Input or output is not activated	Input is activated (input voltage is indicated even if supply is switched off)	-
Error indications left (see No. 5 in the following figure)	Error indication	Red	No error	Internal error	-
Error indications right (see No. 5 in the following figure)	Error indication	Red	No error	Internal error	Overload or short circuit on a channel of the corresponding group
Indication supply voltage (see No. 6 in the following figure)	Process voltage	Green	Process voltage not available	Process voltage OK	-

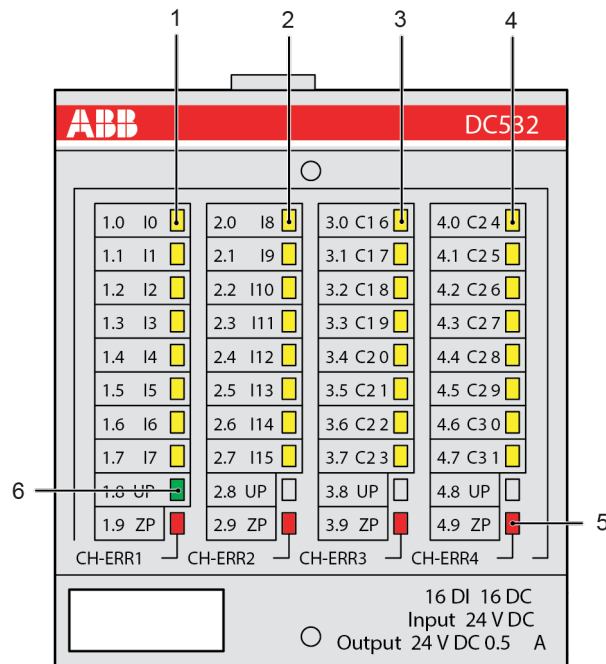

Fig. 56: Front view: DC532

1.5.4.8 Technical data

This section provides additional information on section ↗ *Chapter 1.3 “System data and CS31 bus system data” on page 4*. In case of doubt, the following information applies.

1.5.4.8.1 Technical Data of the complete device

Data	Value
Process voltage:	
-> Connections	X4/L+ (pin 22), X4/L+ (pin 23), X4/M (pin 24), X4/M (pin 25)
-> Fuse for L+	10 A, fast acting
- Galvanic isolation	No
Current consumption:	
-> via L+	0.19 A and max. 0.5 A per output
- Inrush current via L+ (when voltage is switched on)	0.17 A ² s
Power consumption	Replacement device: 200 W Existing device: 202 W
Max. power dissipation within the module (outputs unloaded)	Replacement device: 6 W Existing device: 5 W
Address setting and configuration	DIP switch on right side of the housing
Operating and error indications	Replacement device: 41 LEDs Existing device: 33 LEDs



For further information, please refer to the existing documentation System description Advant Controller 31.



CAUTION!

System damage caused by voltage!

Exceeding the maximum supply or process voltage (>30 V DC) results in permanent system damage (destruction).

1.5.4.8.2 Technical data of the digital inputs

Data	Value
Connections	X2/1.0, X2/1.1, X2/1.2, X2/1.3, X2/1.4, X2/1.5, X2/1.6, X2/1.7, X3/2.0, X3/2.1, X3/2.2, X3/2.3, X3/2.4, X3/2.5, X3/2.6, X3/2.7
Input type according to EN 61131-2	Type 1 (realized through current sink)
Input delay: 0 -> 1 or 1 -> 0 *)	Replacement device: Typ. 8 ms Existing device: Typ. 7 ms
Indication of the input signals	Replacement device: One yellow LED per channel. The LED corresponds functionally to the input signal. Existing device: One green LED per channel. The LED corresponds functionally to the input signal.
Input signal voltage:	24 V DC
-> 0 signal	Replacement device: -3 V...+5 V Existing device: -30 V...+5 V
-> Undefined signal	Replacement device: > +5 V...< +15 V Existing device: > +5 V...< +13 V
-> 1 signal	Replacement device: +15 V...+30 V Existing device: +13 V...+30 V
-> Residual ripple at 0 signal	Replacement device: within -3 V...+5 V Existing device: within -30 V...+5 V
-> Residual ripple at 1 signal	Replacement device: within +15 V...+30 V Existing device: within +13 V...+30 V
Input current per channel:	
Input voltage +24 V	Replacement device: Typ. 5 mA Existing device: Typ. 7 mA
Input voltage +5 V	Replacement device: > 1 mA Existing device: ≥ 1 mA
Input voltage +15 V	Replacement device: > 5 mA Existing device: ≥ 2 mA (at input voltage +13 V)

Data	Value
Input voltage +30 V	Replacement device: < 8 mA Existing device: ≤ 9 mA
Maximum cable length:	
-> Shielded	1000 m
-> Unshielded	600 m
Protection against reversed voltage	Yes
Overvoltage protection	Up to 30 V DC

*) Input delay of the S500 module DC532. The transmission rate via serial buses has not been taken into account.



For further information, please refer to the existing documentation [System description Advant Controller 31](#).

1.5.4.8.3 Technical data of the digital outputs

Data	Value
Connections	X5/3.0, X5/3.1, X5/3.2, X5/3.3, X5/3.4, X5/3.5, X5/3.6, X5/3.7
Type of digital outputs	High-side switch
Demagnetization with inductive load	With a varistor inside the device (with other circuitry)
Switching frequency with ohmic load	On request
Output voltage at signal 1	X4 / L+ (typ. 24 V) -0.8 V
Output delay: 0 -> 1 or 1 -> 0	On request
Maximum cable length:	
-> Shielded	1000 m
-> Unshielded	600 m



For further information, please refer to the existing documentation [System description Advant Controller 31](#).

1.5.4.8.4 Technical data of the configurable inputs/outputs

Data	Value
Connections	X6/4.0, X6/4.1, X6/4.2, X6/4.3, X6/4.4, X6/4.5, X6/4.6, X6/4.7
Use as digital input	See Chapter 1.5.4.8.2 "Technical data of the digital inputs" on page 122
Use as digital output	See Chapter 1.5.4.8.3 "Technical data of the digital outputs" on page 123

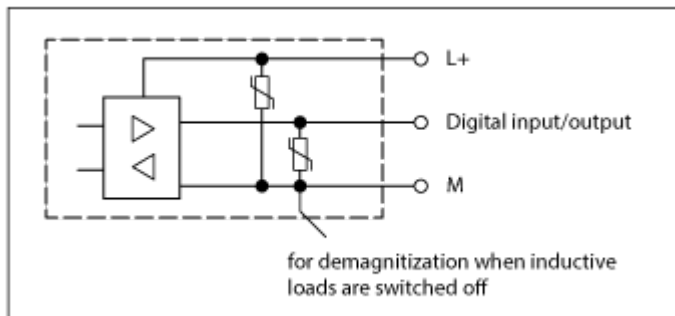

Fig. 57: Protective circuits inputs/outputs

i Due to the changed protective circuit on the inputs and outputs, the restrictions concerning the input signal voltage described in the existing documentation no longer apply.

i When the channels of connector X6 are to be used as inputs, the respective outputs (high-end switches) must be switched off.

1.5.4.8.5 Connection to the CS31 bus

Data	Value
Connections	X1/B2, X1/B1
CS31 bus type	04 (digital input/output)
Terminating resistor	Not available (must be provided externally if needed)

1.5.4.8.6 Mechanical data

Data	Value
Width x height x depth	Replacement device: 120 x 140 x approx. 80 mm Existing device: 120 x 140 x 85 mm
Weight	Replacement device: 351 g (incl. terminals) Existing device: 450 g
Dimensions for mounting	See operating and assembly instructions of the replacement device (3ADR020083M0401)

1.5.4.8.7 Assembly / Disassembly

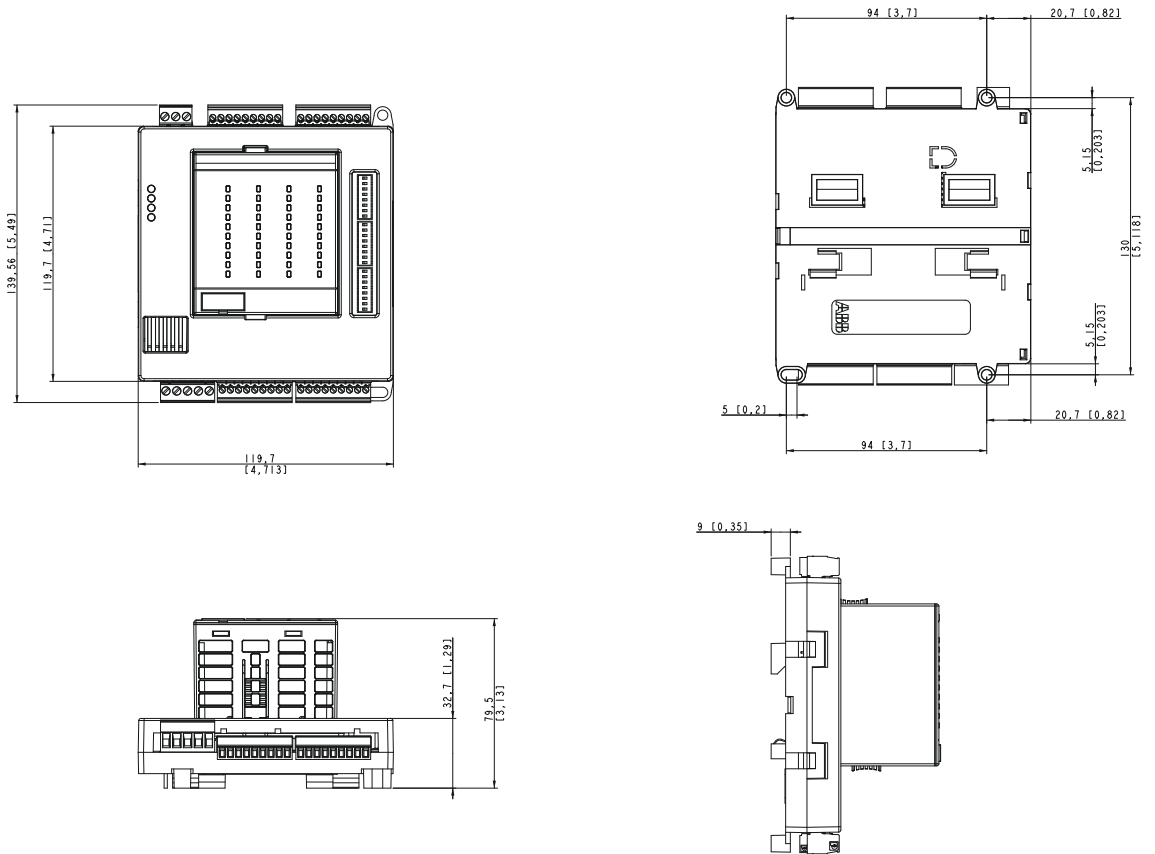

 *The dimensions are in mm and in brackets in inch.*

 *The dimensions for the assembly holes are the same for the replacement device and the existing device.*

To assemble or disassemble the replacement device, grab the device at the housing and not directly at the S500 module.

 **CAUTION!**
System damage caused by voltage!
 The exchange of a replacement device under voltage can cause permanent system damage (destruction).

1.5.4.8.8 Ordering data

Order No.	Scope of delivery
1SAP 800 300 R0010	Digital input/output module 07DC91-AD 1 5-pin terminal block (5.08 mm grid space) 1 3-pin terminal block (5.08 mm grid space) 4 9-pin terminal blocks (3.81 mm grid space)

1.5.5 Replacement device 07DC92-AD



Fig. 58: 3ADR333196F0015_07DC92-AD

The replacement device 07DC92-AD of the AC31 adapter series replaces the existing device 07DC92 of the 90 series.

During the development of the replacement device, care was taken to keep the device configuration identical to the configuration of the existing device. Thus, the existing documentation of device 07DC92 remains valid and serves as a reference (*system description Advant Controller 31*). The document structure of this document is based on the document structure of the existing documentation.

This document adds the following points to the still valid existing documentation:

- Unavoidable device deviations, e.g. due to technical limitations.
- Expansion of documentation as a result of normative requirements.
- Additional contents not described in the existing documentation.

Further information on replacement device 07DC92-AD can be found in the operating and assembly instructions of device 07DC92-AD: 3ADR020151M0401 *operating and assembly instructions of device 07DC92-AD*. Please note that no separate operating and assembly instructions are available for device 07DC92.

Please also observe the system data as well as the information on CS31 bus ↪ *Chapter 1.3 "System data and CS31 bus system data" on page 4.*

1.5.5.1 Device configuration

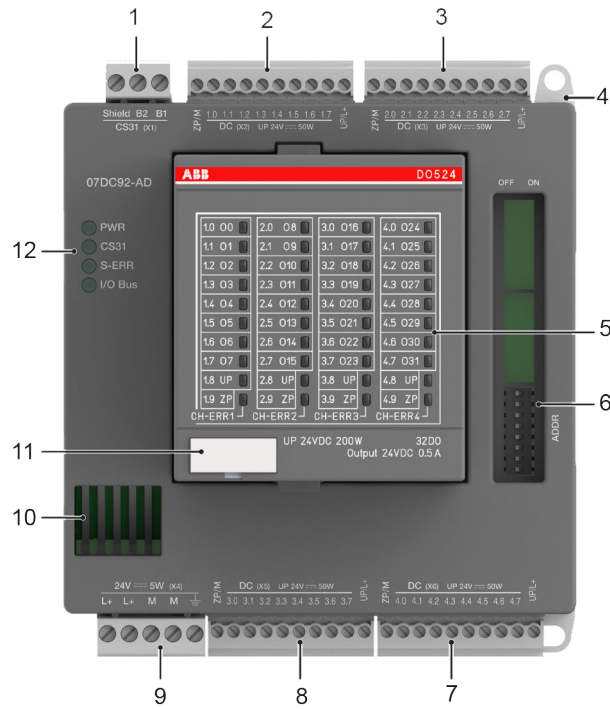

- 1 Connector X1: CS31 bus
- 2 Connector X2: 8 DC + voltage supply (incl. DO524)
- 3 Connector X3: 8 DC + voltage supply (incl. DO524)
- 4 Hole for screw mounting (screw diameter 4 mm, extension torque 1.2 Nm)
- 5 Status LEDs for DO524
- 6 DIP switch for address setting (ADDR)
- 7 Connector X6: 8 DC + voltage supply (incl. DO524)
- 8 Connector X5: 8 DC + voltage supply (incl. DO524)
- 9 Connector X4: Voltage supply (incl. DO524)
- 10 Ventilation
- 11 TA525: Label
- 12 4 LEDs to display the status of the complete 07DC92-AD device

1.5.5.2 LED display

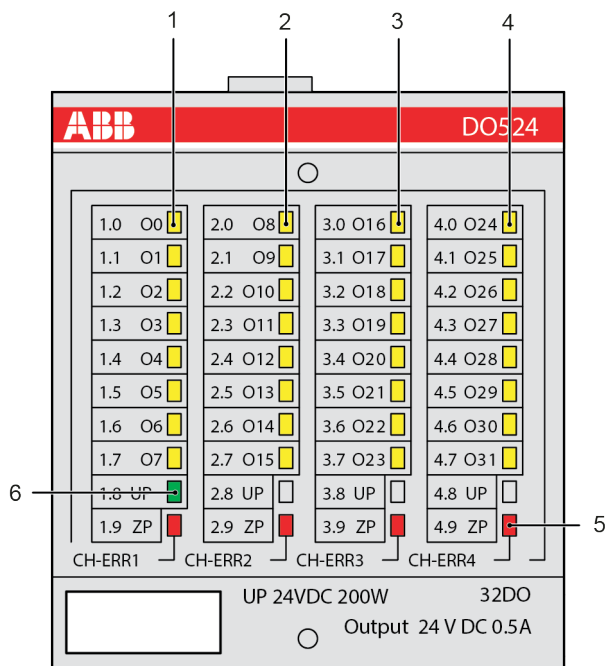

Fig. 59: LEDs DO524

No.	Displays of module
1	8 yellow LEDs to indicate the signal states of the digital inputs/outputs (X2).
2	8 yellow LEDs to indicate the signal states of the digital inputs/outputs (X3).
3	8 yellow LEDs to indicate the signal states of the digital inputs/outputs (X5).
4	8 yellow LEDs to indicate the signal states of the digital inputs/outputs (X6).
5	4 red LEDs to indicate errors (from the DO524 module).
6	1 green LED to indicate the status of the supply voltage of the DO524 module (is supplied via UP/L+).



The replacement device does not provide a test button to measure functionality.

1.5.5.3 Connections

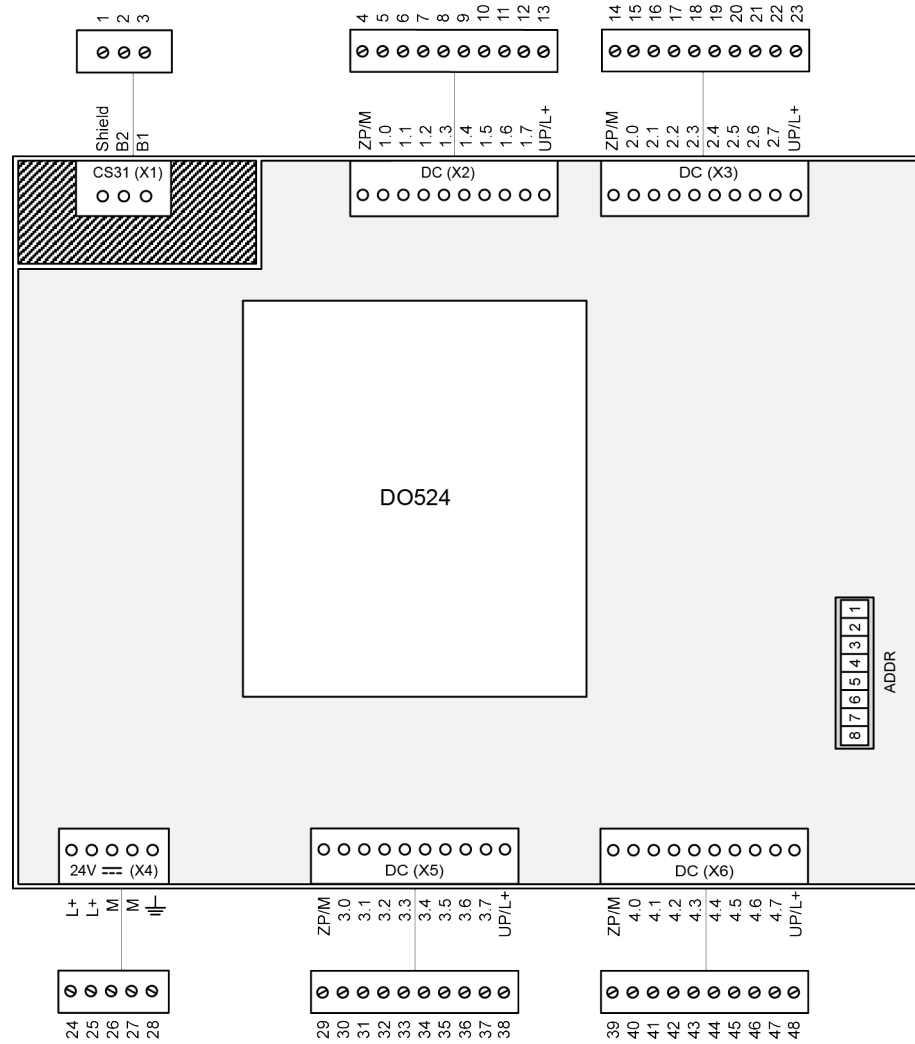

Fig. 60: Connection

Table 72: Pin assignment CS31 bus (X1)

Connector / Terminal	Pin	Assignment / Signal
X1 / Shield	1	No internal connection
X1 / B2	2	BUS 2
X1 / B1	3	BUS 1

 The shield connection of the CS31 bus is not galvanically connected to the functional earth of the supply voltage.

Table 73: Pin assignment DC (X2)

Connector / Terminal	Pin	Assignment / Signal
X2 / ZP/M	4	ZP/M
X2 / 1.0	5	DO524 / O0
X2 / 1.1	6	DO524 / O1

Connector / Terminal	Pin	Assignment / Signal
X2 / 1.2	7	DO524 / O2
X2 / 1.3	8	DO524 / O3
X2 / 1.4	9	DO524 / O4
X2 / 1.5	10	DO524 / O5
X2 / 1.6	11	DO524 / O6
X2 / 1.7	12	DO524 / O7
X2 / UP/L+	13	UP/L+

Table 74: Pin assignment DC (X3)

Connector / Terminal	Pin	Assignment / Signal
X3 / ZP/M	14	ZP/M
X3 / 2.0	15	DO524 / O8
X3 / 2.1	16	DO524 / O9
X3 / 2.2	17	DO524 / O10
X3 / 2.3	18	DO524 / O11
X3 / 2.4	19	DO524 / O12
X3 / 2.5	20	DO524 / O13
X3 / 2.6	21	DO524 / O14
X3 / 2.7	22	DO524 / O15
X3 / UP/L+	23	UP/L+

Table 75: Pin assignment 24 V DC (X4)

Connector / Terminal	Pin	Assignment / Signal
X4 / L+	24	L+
X4 / L+	25	L+
X4 / M	26	M
X4 / M	27	M
X4 / FE	28	FE

Table 76: Pin assignment DC (X5)

Connector / Terminal	Pin	Assignment / Signal
X5 / ZP/M	29	ZP/M
X5 / 3.0	30	DO524 / O16
X5 / 3.1	31	DO524 / O17
X5 / 3.2	32	DO524 / O18
X5 / 3.3	33	DO524 / O19
X5 / 3.4	34	DO524 / O20
X5 / 3.5	35	DO524 / O21
X5 / 3.6	36	DO524 / O22
X5 / 3.7	37	DO524 / O23
X5 / UP/L+	38	UP/L+

Table 77: Pin assignment DC (X6)

Connector / Terminal	Pin	Assignment / Signal
X6 / ZP/M	39	ZP/M
X6 / 4.0	40	DO524 / O24
X6 / 4.1	41	DO524 / O25
X6 / 4.2	42	DO524 / O26
X6 / 4.3	43	DO524 / O27
X6 / 4.4	44	DO524 / O28
X6 / 4.5	45	DO524 / O29
X6 / 4.6	46	DO524 / O30
X6 / 4.7	47	DO524 / O31
X6 / UP/L+	48	UP/L+



CAUTION!

System damage caused by voltage!

The exchange of a replacement device under voltage can cause permanent system damage (destruction).

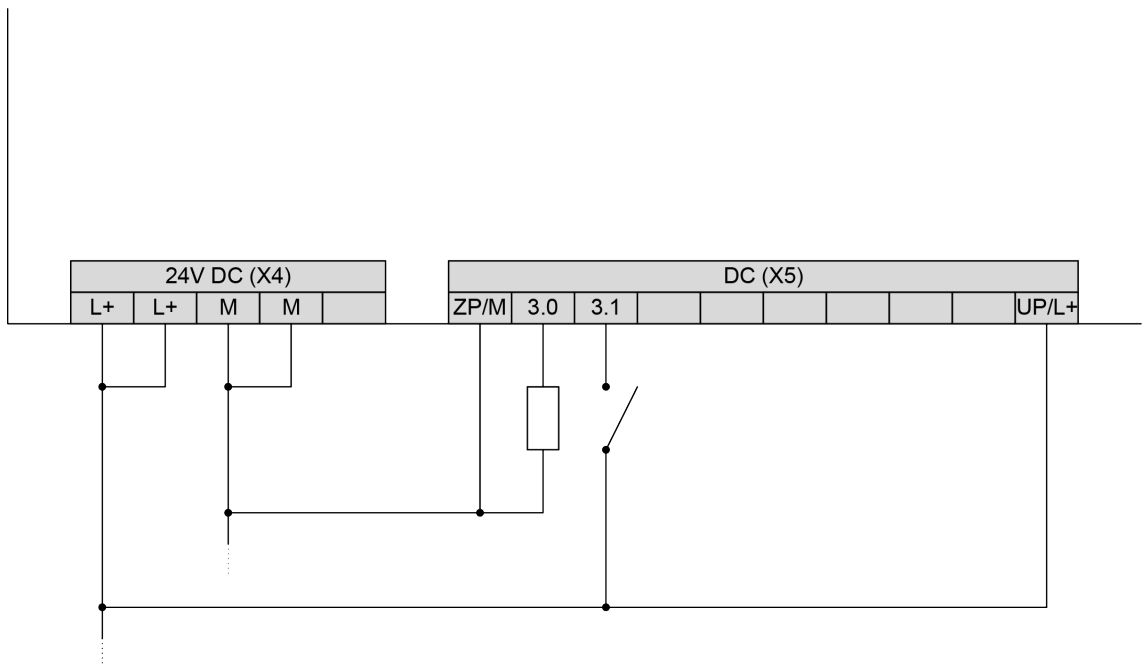

Fig. 61: Connection example: digital output

1.5.5.4 Addressing

In the following, the information in the "Type" column refers to the data type designation of the Automation Builder (see AC31 system data ↗ *Chapter 1.3 "System data and CS31 bus system data" on page 4*). The information in the "Type" column must be interpreted from the viewpoint of the CS31 bus master. The information in brackets must be interpreted from the viewpoint of the replacement device (CS31 bus slave).

Table 78: CS31 bus (32 inputs / 32 outputs)

Byte	Type	Bit	Connector / Terminal
1	8 bit input (send)	0 ... 7	X2 / 1.0 ... 1.7
2	8 bit input (send)	0 ... 7	X3 / 2.0 ... 2.7
3	8 bit input (send)	0 ... 7	X5 / 3.0 ... 3.7
4	8 bit input (send)	0 ... 7	X6 / 4.0 ... 4.7
5	8 bit output (receive)	0 ... 7	X2 / 1.0 ... 1.7
6	8 bit output (receive)	0 ... 7	X3 / 2.0 ... 2.7
7	8 bit output (receive)	0 ... 7	X5 / 3.0 ... 3.7
8	8 bit output (receive)	0 ... 7	X6 / 4.0 ... 4.7

Table 79: CS31 bus (32 outputs)

Byte	Type	Bit	Connector / Terminal
1	8 bit output (receive)	0 ... 7	X2 / 1.0 ... 1.7
2	8 bit output (receive)	0 ... 7	X3 / 2.0 ... 2.7
3	8 bit output (receive)	0 ... 7	X5 / 3.0 ... 3.7
4	8 bit output (receive)	0 ... 7	X6 / 4.0 ... 4.7



NOTICE!

In case of overloading or a short-circuit, the output limits the electricity and switches off thermally. The LED of the overloaded output is also switched off and the corresponding error indication of the DO524 flashes.

1.5.5.5 I/O configuration

The existing device had a DIP switch on the upper printed circuit board. Since the replacement device is not equipped with an upper printed circuit board, the white DIP switch is arranged on the lower printed circuit board instead.

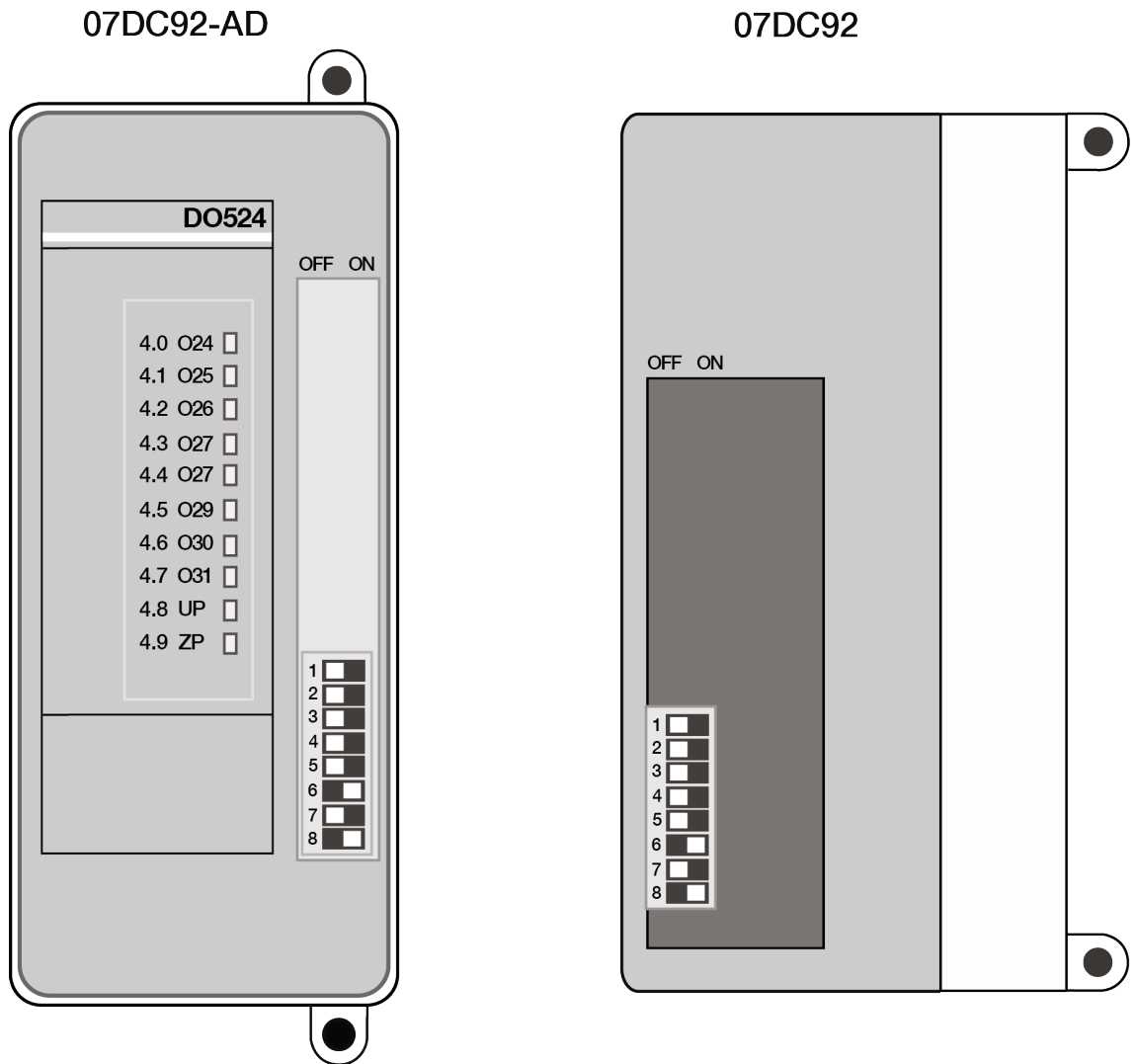

Fig. 62: DIP switch for 07DC92-AD:



The DIP switches are read by the device only once after the supply voltage has been connected.



For further information, please refer to the existing documentation System description Advant Controller 31.

1.5.5.6 Behavior during normal operation

Interpretation of the LEDs:

- The device initializes automatically after the supply voltage is switched on. During this time, the S-ERR LED flashes.
- The PWR LED lights up as soon as the internal supply voltage of the device is present.
- After successful initialization of the I/O bus communication to the S500 module, the I/O bus LED lights up.

- After successful initialization of the CS31 bus communication, the CS31 bus LED lights up. The S-ERR LED goes out.
- During operation, the yellow LEDs indicate the signal states of the channels.

1.5.5.7 Diagnosis and Displays

LEDs are used for diagnosis and display purposes. In addition, some diagnosis information can be transmitted via the CS31 bus.



The replacement device does not provide a test button to measure functionality.

Table 80: Diagnosis information of the CS31 bus

Error description	Channel	Error code (CODESYS)	Error code (CS31 bus)	Description
Device error	0	43	1	Internal error
Channel error	0, 8, 15 *)	46	4	Overload or short circuit on a digital output

*) The channel numbers are grouped as follows:

0 - for X2 / 1.0 ... 1.7

8 - for X2 / 2.0 ... 2.7

15 - for X5 / 3.0 ... 3.7 and X6 / 4.0 to 4.7



The error codes that are transferred by the replacement device via the CS31 bus are newly displayed in CODESYS. Each error code of the CS31 bus (table column 3) produces the error code in CODESYS (table column 2). As a result, it is possible to operate the replacement device with a new control system (PLC/control unit), e.g. 07KT98-ARC-AD, as well as with an old control system (PLC/central unit), e.g. 07KT98.

Table 81: Device LEDs

LED	Status	Color	LED off	LED on	LED flashes
PWR	Voltage supply	Green	No internal supply voltage	Internal supply voltage	-
CS31 bus	CS31 bus communication	Green	No CS31 bus communication	CS31 bus communication	Only diagnosis, no data transfer. Transmission is disturbed.
S-ERR	Error	Red	No error	Static error (must be confirmed by the control system)	No CS31 bus connection or activity
I/O bus	I/O bus communication	Green	No I/O bus communication	I/O bus communication	Error I/O bus communication

The S-ERR LED remains on even if the error no longer occurs. The error must be confirmed by the control system (PLC/central unit), e.g. by means of a function block  Chapter 1.3 "System data and CS31 bus system data" on page 4.

Special cases with rapidly flashing LEDs (approx. 5 Hz):

- All 4 LEDs flash rapidly: An incorrect S500 module is connected to the device. The device fails to initialize.
- The LEDs of the CS31 bus, S-ERR bus and I/O bus flash rapidly: Invalid position of DIP switches. The device fails to initialize.
- The LEDs of the S-ERR bus and I/O bus flash rapidly: A checksum error occurred in an internal flash memory.
- The LED of the I/O bus flashes rapidly: An error occurred in an internal RAM.

Table 82: LEDs of the S500 module DO524

LED	Status	Color	LED off	LED on	LED flashes
O0...O7 (see No. 1 in the following figure)	Digital inputs/ outputs	Yellow	Input/output is not activated	Input/output is activated (input voltage is indicated even if supply is switched off)	-
I8 to I15 (see No. 2 in the following figure)	Digital inputs/ outputs	Yellow	Input/output is not activated	Input/output is activated (input voltage is indicated even if supply is switched off)	-
O16 to O23 (see No. 3 in the following figure)	Digital inputs/ outputs	Yellow	Input/output is not activated	Input/output is activated (input voltage is indicated even if supply is switched off)	-
C24 to C31 (see No. 4 in the following figure)	Digital inputs/ outputs	Yellow	Input/output is not activated	Input/output is activated (input voltage is indicated even if supply is switched off)	-
Error indications right (see No. 5 in the following figure)	Error indication	Red	No error	Internal error	Overload or short circuit on a channel of the corresponding group
Indication supply voltage (see No. 6 in the following figure)	Process voltage	Green	Process voltage not available	Process voltage OK	-

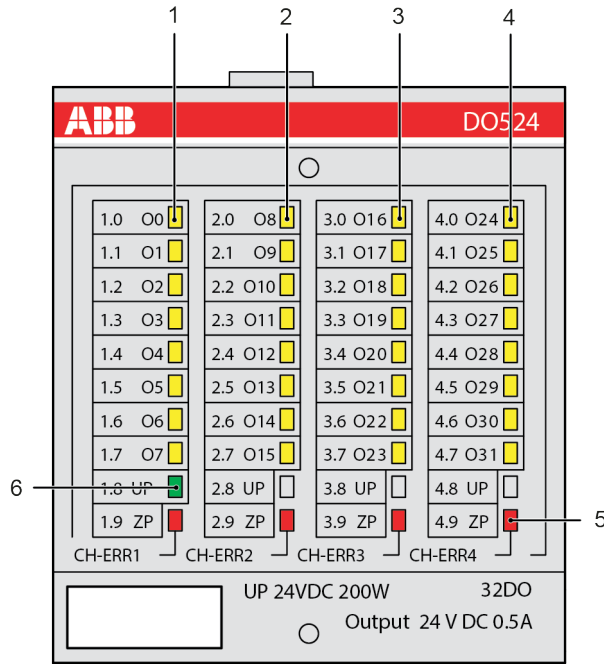

Fig. 63: LEDs DO524

1.5.5.8 Technical data

This section provides additional information on section ↗ *Chapter 1.3 “System data and CS31 bus system data” on page 4*. In case of doubt, the following information applies.

1.5.5.8.1 Technical data of the complete device

Data	Value
Process voltage:	
-> Connections L+	X2 (pin 13) X3 (pin 23), X4 (pin 24, pin 25) X5 (pin 38), X6 (pin 48)
-> Connections M	X2 (pin 4) X3 (pin 14) X4 (pin 26, pin 27) X5 (pin 29) X6 (pin 39)
-> Fuse for L+	10 A, fast acting
- Galvanic isolation	None (07DC92: Group against group, all groups in relation to the rest of the device)
Current consumption:	
-> via L+	0.19 A and max. 0.5 A per output
- Inrush current via L+ (when voltage is switched on)	0.17 A ² s

Data	Value
Power consumption	Replacement device: 200 W Existing device: 394 W
Max. power dissipation within the module (outputs unloaded)	Replacement device: 6 W Existing device: 5 W
Address setting and configuration	DIP switch right side of housing
Operating and error indications	Replacement device: 41 LEDs Existing device: 33 LEDs

 For further information, please refer to the existing documentation System description Advant Controller 31.

 **CAUTION!**
System damage caused by voltage!
 Exceeding the maximum supply or process voltage (>30 V DC) results in permanent system damage (destruction).

Changes to the process voltage connections

07DC92

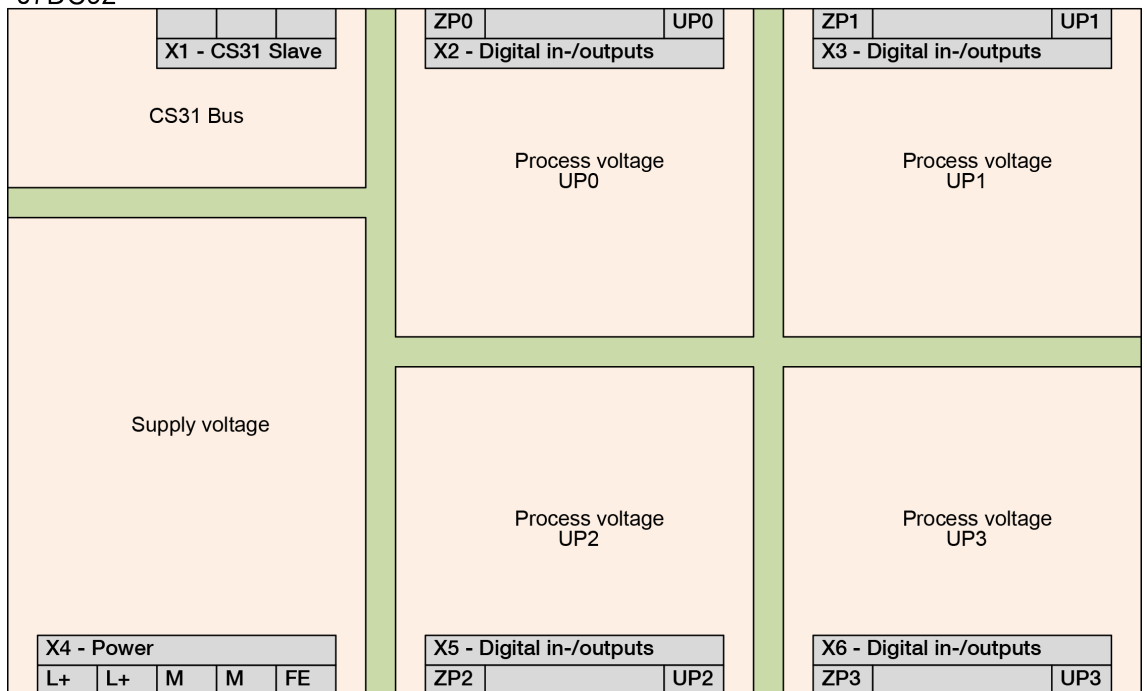



Fig. 64: Process voltage connections - 07DC92

 **CAUTION!**
System damage caused by voltage!
 Changed potential ranges!

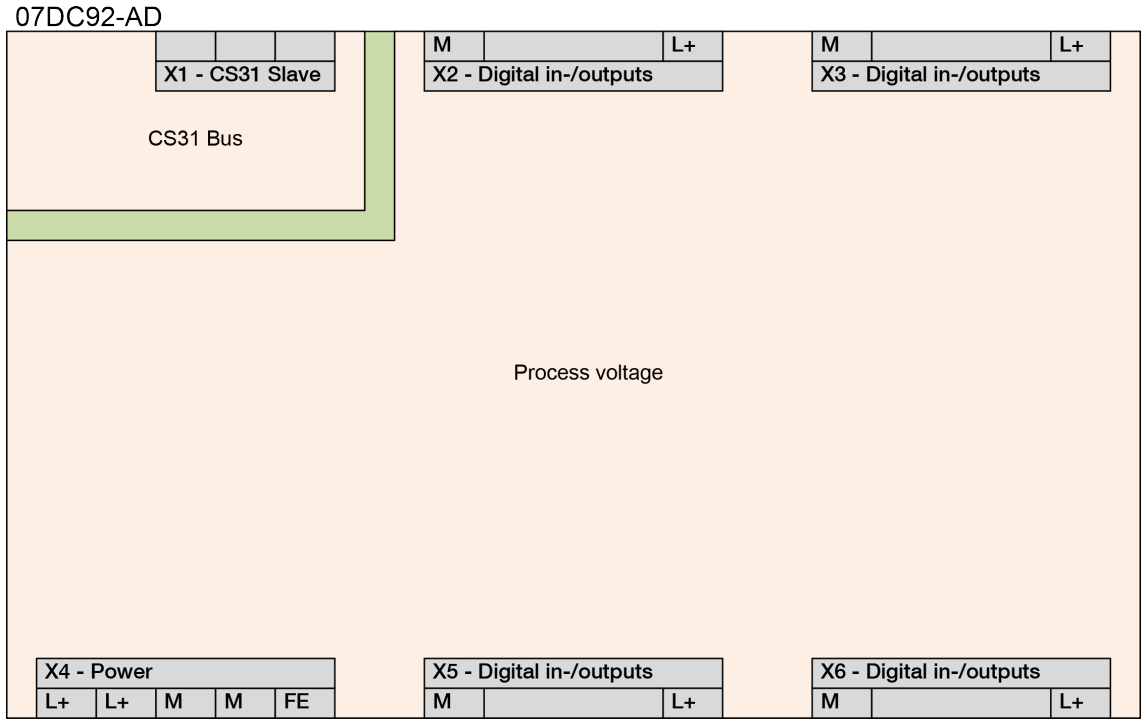

Fig. 65: Process voltage connections - 07DC92-AD

NOTICE!
 Process voltage must always be connected to connector X4 on device 07DC92-AD.

Connector X4 also supplies the internal electronics for the device 07DC92-AD with 0.15 A.

i *Process voltage connections (X2, X3, X5, X6):*

- Maximum current for digital outputs X2 + X3: 4 A / 4 to
- Maximum current for digital outputs X5 + X6: 4 A / 4 to

i

- Input currents > 4 A require the connection of the second L+ contact of connector X4.
- For input currents > 8 A, additional L+ contacts from X2, X3, X5 or X6 must be used.
- The L+ contacts for the connectors X2, X3, X5 or X6 may be loaded with a maximum of 4 A.

1.5.5.8.2 Technical details of the I/O channels as binary inputs

Data	Value
Connections	X2 / 1.0 ... 1.7 X3 / 2.0 ... 2.7 X5 / 3.0 ... 3.7 X6 / 4.0 ... 4.7
Input type according to EN 61131-2	Type 1 (realized through resistors)

Data	Value
Input delay: 0 -> 1 or 1 -> 0 *)	Replacement device: Type. 8 ms Existing device: Type. 7 ms
Indication of the input signals	Replacement device: One yellow LED per channel. The LED corresponds functionally to the input signal. Existing device: One green LED per channel. The LED corresponds functionally to the input signal.
Input signal voltage:	24 V DC
-> 0 signal	Replacement device: -3 V...+5 V Existing device: -6 V...+5 V
-> Undefined signal	Replacement device: > +5 V...< +15 V Existing device: > +5 V...< +13 V
-> 1 signal	Replacement device: +15 V...+30 V Existing device: +13 V...+30 V
-> Residual ripple at 0 signal	Replacement device: within -3 V...+5 V Existing device: within -6 V...+5 V
-> Residual ripple at 1 signal	Replacement device: within +15 V...+30 V Existing device: within +13 V...+30 V
Input current per channel:	
Input voltage +24 V	Replacement device: Type. 3.5 mA / 4 to Existing device: Type. 7 mA / 4 to
Input voltage +5 V	Replacement device: > 0.5 mA Existing device: ≥ 0.2 mA
Input voltage +15 V	Replacement device: > 2 mA Existing device: ≥ 2 mA (at input voltage +13 V)
Maximum cable length:	
-> Shielded	1000 m
-> Unshielded	600 m
Protection against reversed voltage	Yes
Overvoltage protection	Up to 30 V DC

*) Input delay of the S500 module DO524. The transmission rate via serial buses has not been taken into account.



For further information, please refer to the existing documentation [System description Advant Controller 31](#).

1.5.5.8.3 Technical details of the I/O channels as digital outputs

Data	Value
Connections	X2 / 1.0 ...1.7 X3 / 2.0 ... 2.7 X5 / 3.0 ... 3.7 X6 / 4.0 ... 4.7
Type of digital outputs	High-side switch
Reference potentials for the outputs	M (07DC92: ZP0, ZP1, ZP2 and ZP3)
Supply voltage for the outputs	L+ (07DC92: UP0, UP1, UP2 and UP3)
Galvanic isolation	No (07DC92: Group against group, all groups in relation to the rest of the device)
Output current (maximum value)	X2 + X3 = 4 A, X5 + X6 = 4 A (07DC92: 4 A per group)
Demagnetization with inductive load	Internally with a varistor (with other circuitry)
Switching frequency with ohmic load	On request
Output voltage at signal 1	X4 / L+ (typ. 24 V) -0.8 V
Output delay: 0 -> 1 or 1 -> 0	On request
Maximum cable length:	
-> Shielded	1000 m
-> Unshielded	600 m



For further information, please refer to the existing documentation [System description Advant Controller 31](#).

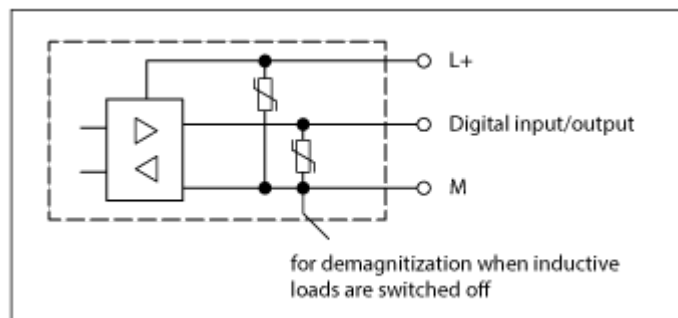

Fig. 66: Protective circuits inputs/outputs



Due to the changed protective circuit on the inputs and outputs, the restrictions concerning the input signal voltage described in the existing documentation no longer apply.



If the channels are to be used as inputs, the respective outputs (high-side switches) must be switched off.

1.5.5.8.4 Connection to the CS31 bus

Data	Value
Connections	X1/B2, X1/B1
CS31 bus type	04 (digital input/output)
Terminating resistor	Not available (must be provided externally if needed)

1.5.5.8.5 Mechanical data

Data	Value
Width x height x depth	Replacement device: 120 x 140 x approx. 80 mm Existing device: 120 x 140 x 85 mm
Weight	Replacement device: 351 g (incl. terminals) Existing device: 450 g
Dimensions for mounting	See operating and assembly instructions of the replacement device (3ADR020151M0401) <i>operating and assembly instructions of device 07DC92-AD</i>

1.5.5.8.6 Assembly / Disassembly

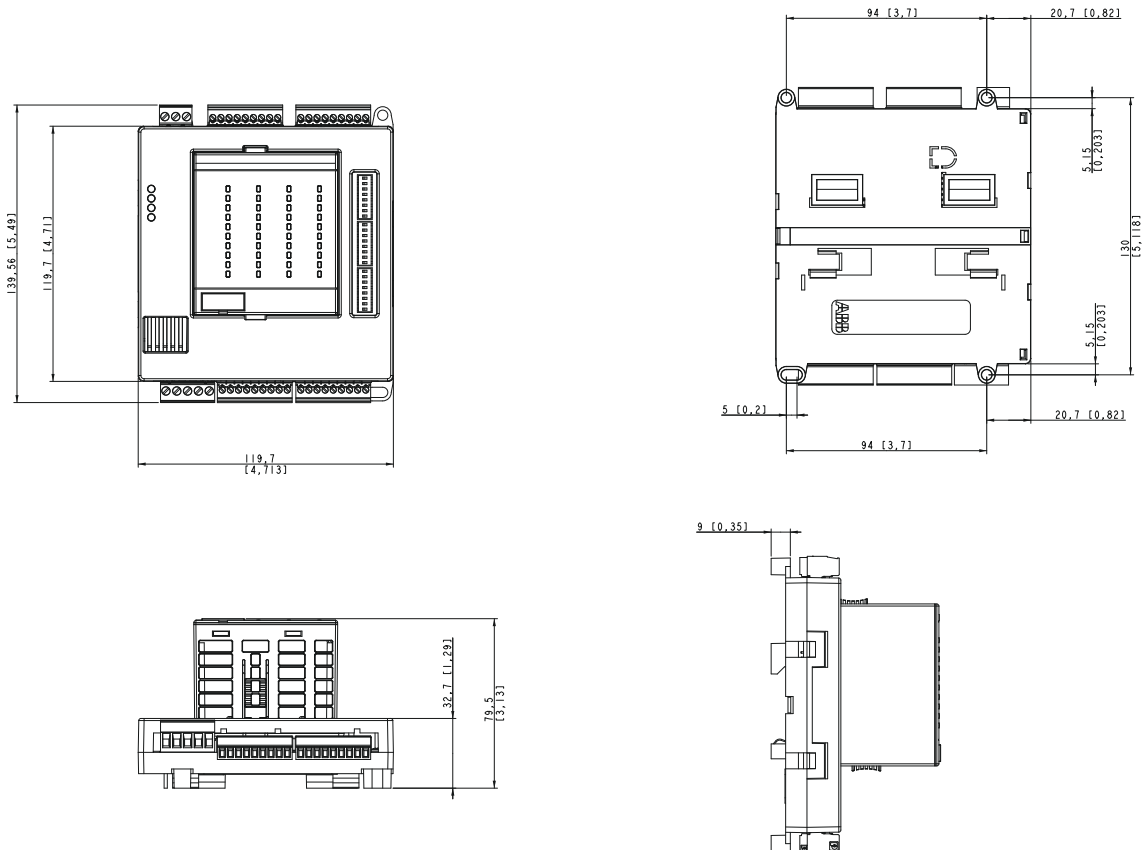



The dimensions are in mm and in brackets in inch.



The dimensions for the assembly holes are the same for the replacement device and the existing device.

To assemble or disassemble the replacement device, grab the device at the housing and not directly at the S500 module.



CAUTION!

System damage caused by voltage!

The exchange of a replacement device under voltage can cause permanent system damage (destruction).

1.5.5.8.7 Ordering data

Order No.	Scope of delivery
1SAP 800 500 R0010	Digital input/output module 07DC92-AD 1 5-pole terminal block (5.08 mm grid space) 1 3-pole terminal block (5.08 mm grid space) 4 10-pole terminal blocks (3.81 mm grid space)

1.5.6 Replacement unit DC501-CS31-AD

1.5.6.1 Introduction



Fig. 67: 3ADR331189S0015_DC501-CS31-AD

The replacement device DC501-CS31-AD of the AC31 adapter series replaces the existing device DC501-CS31.

The existing device DC501-CS31 supported the use of so-called extension box modules to increase I/O functionality. The following modules were supported:

- Module AX501 for analog signals: 3 analog inputs, 1 analog output
- Module DI501 for digital signals: 4 digital inputs
- Module DO501 for relay output: 8 relays

The replacement device DC501-CS31-AD does not support the use of extension box modules. Instead, the functionality of modules AX501 and DI501 is integrated in the replacement device. The functionality of module DO501 is not supported.

This document describes only changes that have been integrated in the replacement device and expansions to the existing device DC501-CS31. Thus, *the existing documentation of device DC501-CS31 remains valid and serves as reference*. The extension box modules are documented in the existing documentation of the I/O-S500 hardware. This description is replaced by this document.

This document adds the following points to the still valid existing documentation:

- Unavoidable device deviations, e.g. due to technical limitations.
- Expansion of documentation as a result of normative requirements.
- Additional contents not described in the existing documentation.

Further information on replacement device DC501-CS31-AD can be found in the operating and assembly instructions of device DC501-CS31-AD: 3ADR020087M0401. Please note that for device DC501-CS31 no separate operating and assembly instructions are available.

Please also observe the system data as well as the information on CS31 bus [Chapter 1.3 “System data and CS31 bus system data”](#) on page 4.

1.5.6.2 Device configuration

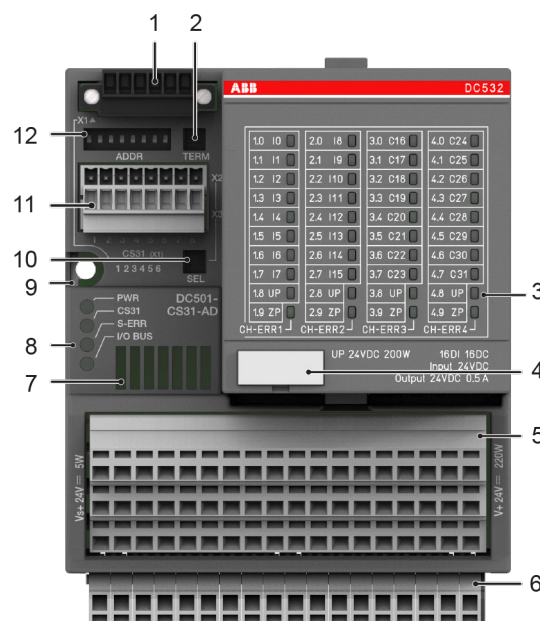

- 1 Connection for CS31 bus (X1)
- 2 Bus termination (CS31 bus)
- 3 Status LEDs for DC532
- 4 TA525: Label
- 5 Terminals signal level (X4). 16 digital inputs, 8 digital outputs, 8 DC voltage supply (incl. DC532)
- 6 Terminals signal level (plug-in power bus)
- 7 Ventilation
- 8 4 Status LEDs
- 9 Hole for screw mounting (screw diameter 4 mm, extension torque 1.2 Nm)
- 10 Function selector switch for I/O extension
- 11 4 digital inputs (X2): 24 V DC. 3 analog inputs, 1 analog output (X3): 0 V ... +10 V.
- 12 DIP switch for ADDR (X1)

1.5.6.2.1 LED display

The LED display on the replacement device is changed:

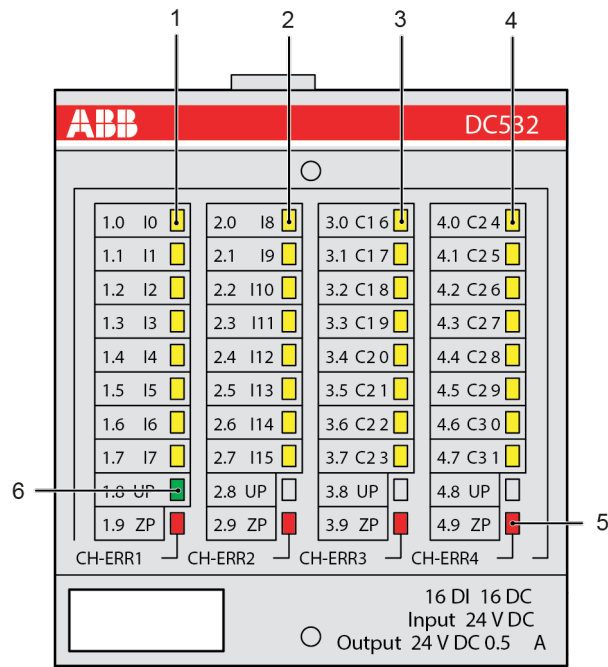

Fig. 68: Front view: DC532

No.	Displays of module
1	8 yellow LEDs to indicate the signal states of the digital inputs (X2).
2	8 yellow LEDs to indicate the signal states of the digital inputs (X3).
3	8 yellow LEDs to indicate the signal states of the digital outputs (X5).
4	8 yellow LEDs to indicate the signal states of the digital inputs/outputs (X6).
5	4 red LEDs to indicate errors (of DC532 module).
6	1 green LED to indicated the status of the supply voltage of the DC532 module (is supplied via X4).

1.5.6.2.2 Connections

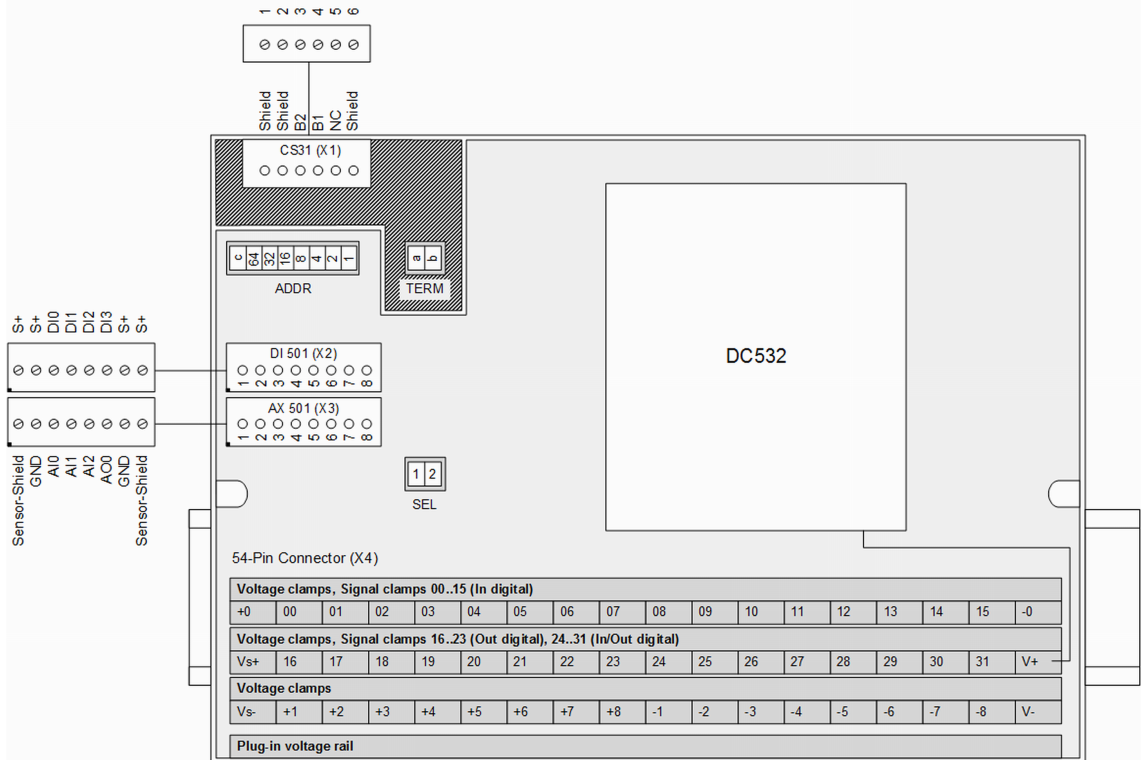

Fig. 69: Connection

Table 83: Pin assignment CS31 bus (X1)

Connector / Terminal	Pin	Assignment / Signal
X1 / Shield	1	Shield (internally connected to pins 2 and 6. No internal connection to functional earth)
X1 / Shield	2	Shield (internally connected to pins 1 and 6. No internal connection to functional earth)
X1 / B2	3	BUS 2
X1 / B1	4	BUS 1
X1 / NC	5	Not connected
X1 / Shield	6	Shield (internally connected to pins 1 and 2. No internal connection to functional earth)



Correction to existing documentation

In the existing documentation, connection X1 / 2 is incorrectly documented as "free / not connected". On the replacement device DC501-CS31-AD, the selection of the pin assignment of connector X1 is identical to the realization of device DC501-CS31. Thus, the pin assignment described in this document is valid for the replacement device and the existing device.

Table 84: Pin assignment DI501 (X2)

Connector / Terminal	Pin	Assignment / Signal
X2 / S+	1	Auxiliary voltage (max. 32 mA total load of S+ permitted) for DI0 - DI3. Voltage derived from input voltage Vs+ (X4)
X2 / S+	2	Auxiliary voltage (max. 32 mA total load of S+ permitted) for DI0 - DI3. Voltage derived from input voltage Vs+ (X4)

Connector / Terminal	Pin	Assignment / Signal
X2 / DI0	3	Digital extension input 0
X2 / DI1	4	Digital extension input 1
X2 / DI2	5	Digital extension input 2
X2 / DI3	6	Digital extension input 3
X2 / S+	7	Auxiliary voltage (max. 32 mA total load of S+ permitted) for DI0 - DI3. Voltage derived from input voltage Vs+ (X4)
X2 / S+	8	Auxiliary voltage (max. 32 mA total load of S+ permitted) for DI0 - DI3. Voltage derived from input voltage Vs+ (X4)

Table 85: Pin assignment AX501 (X3)

Connector / Terminal	Pin	Assignment / Signal
X3 / Sensor shield	1	Sensor shield
X3 / GND	2	GND
X3 / AI0	3	Analog extension input 0
X3 / AI1	4	Analog extension input 1
X3 / AI2	5	Analog extension input 2
X3 / AO0	6	Analog extension output 0
X3 / GND	7	GND
X3 / Sensor shield	8	Sensor shield

The connections X3 / 2 and X3 / 7 (GND) are directly connected to X4 / Vs-, X4 / V-. There is no AGND potential in accordance with module AX501. In module AX501, AGND is connected to GND via a resistor.

Both sensor shield connections of X3 are interconnected and jointly connected to FE via 10 M Ω || 4 nF.

The connections X3 / 2 and X3 / 7 (GND) are directly connected to X4 / Vs-, X4 / V-. There is no AGND potential in accordance with module AX501. In module AX501, AGND is connected to GND via a resistor.

Both sensor shield connections of X3 are interconnected and jointly connected to FE via 10 M Ω || 4 nF.

The terminal blocks of X2 and X3 have the following connection data:

- Conductor cross section, single wire/ flexible: 0.14 mm² to 1.5 mm²
- Conductor cross section, flexible with wire-end ferrule (without plastic ferrule): 0.25 mm² to 1.5 mm²
- Conductor cross section, flexible with wire-end ferrule (with plastic ferrule): 0.25 mm² to 0.5 mm²

Table 86: Pin assignment 54 pin connector (X4)

Connector / Block	Pin	Assignment / Signal
X4 / 1	+0	Auxiliary voltage (max. 200 mA total load of +0/ +1/ .../ +7/ +8 permitted). Voltage derived from input voltage V+ (X4)
X4 / 1	00	DC532 / I0
X4 / 1	01	DC532 / I1

Connector / Block	Pin	Assignment / Signal
X4 / 1	02	DC532 / I2
X4 / 1	03	DC532 / I3
X4 / 1	04	DC532 / I4
X4 / 1	05	DC532 / I5
X4 / 1	06	DC532 / I6
X4 / 1	07	DC532 / I7
X4 / 1	08	DC532 / I8
X4 / 1	09	DC532 / I9
X4 / 1	10	DC532 / I10
X4 / 1	11	DC532 / I11
X4 / 1	12	DC532 / I12
X4 / 1	13	DC532 / I13
X4 / 1	14	DC532 / I14
X4 / 1	15	DC532 / I15
X4 / 1	-0	GND
X4 / 2	Vs+	Voltage supply for electronics system (also for functionality of AX501 and DI501)
X4 / 2	16	DC532 / C16
X4 / 2	17	DC532 / C17
X4 / 2	18	DC532 / C18
X4 / 2	19	DC532 / C19
X4 / 2	20	DC532 / C20
X4 / 2	21	DC532 / C21
X4 / 2	22	DC532 / C22
X4 / 2	23	DC532 / C23
X4 / 2	24	DC532 / C24
X4 / 2	25	DC532 / C25
X4 / 2	26	DC532 / C26
X4 / 2	27	DC532 / C27
X4 / 2	28	DC532 / C28
X4 / 2	29	DC532 / C29
X4 / 2	30	DC532 / C30
X4 / 2	31	DC532 / C31
X4 / 2	V+	Voltage supply of inputs/outputs (module DC532 and auxiliary voltage)
X4 / 3	Vs-	GND
X4 / 3	+1	Auxiliary voltage (max. 200 mA total load of +0/ +1/ .../ +7/ +8 permitted). Voltage derived from input voltage V+ (X4)
X4 / 3	+2	Auxiliary voltage (max. 200 mA total load of +0/ +1/ .../ +7/ +8 permitted). Voltage derived from input voltage V+ (X4)

Connector / Block	Pin	Assignment / Signal
X4 / 3	+3	Auxiliary voltage (max. 200 mA total load of +0/ +1/ .../ +7/ +8 permitted). Voltage derived from input voltage V+ (X4)
X4 / 3	+4	Auxiliary voltage (max. 200 mA total load of +0/ +1/ .../ +7/ +8 permitted). Voltage derived from input voltage V+ (X4)
X4 / 3	+5	Auxiliary voltage (max. 200 mA total load of +0/ +1/ .../ +7/ +8 permitted). Voltage derived from input voltage V+ (X4)
X4 / 3	+6	Auxiliary voltage (max. 200 mA total load of +0/ +1/ .../ +7/ +8 permitted). Voltage derived from input voltage V+ (X4)
X4 / 3	+7	Auxiliary voltage (max. 200 mA total load of +0/ +1/ .../ +7/ +8 permitted). Voltage derived from input voltage V+ (X4)
X4 / 3	+8	Auxiliary voltage (max. 200 mA total load of +0/ +1/ .../ +7/ +8 permitted). Voltage derived from input voltage V+ (X4)
X4 / 3	-1	GND
X4 / 3	-2	GND
X4 / 3	-3	GND
X4 / 3	-4	GND
X4 / 3	-5	GND
X4 / 3	-6	GND
X4 / 3	-7	GND
X4 / 3	-8	GND
X4 / 3	V-	GND

Connection data of spring terminals (X4):

- Conductor cross section, single wire: 0.2 mm² to 2.5 mm²
- Conductor cross section, flexible: 0.2 mm² to 1.5 mm² (existing device: 2.5 mm² flexible)
- Conductor cross section, flexible with wire-end ferrule: 0.25 mm² to 1.5 mm²

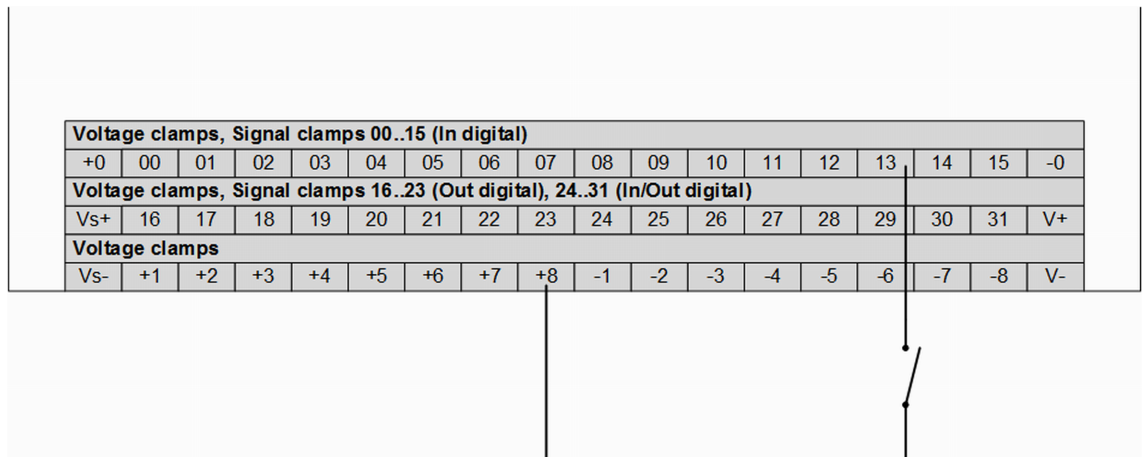

Fig. 70: Connection example: digital input (X4)

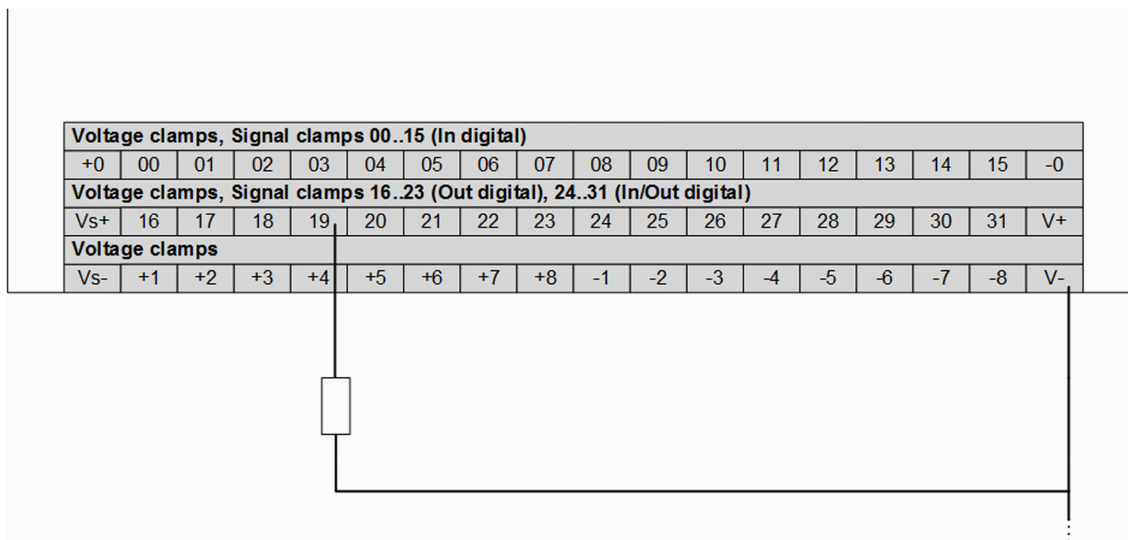

Fig. 71: Connection example: digital output

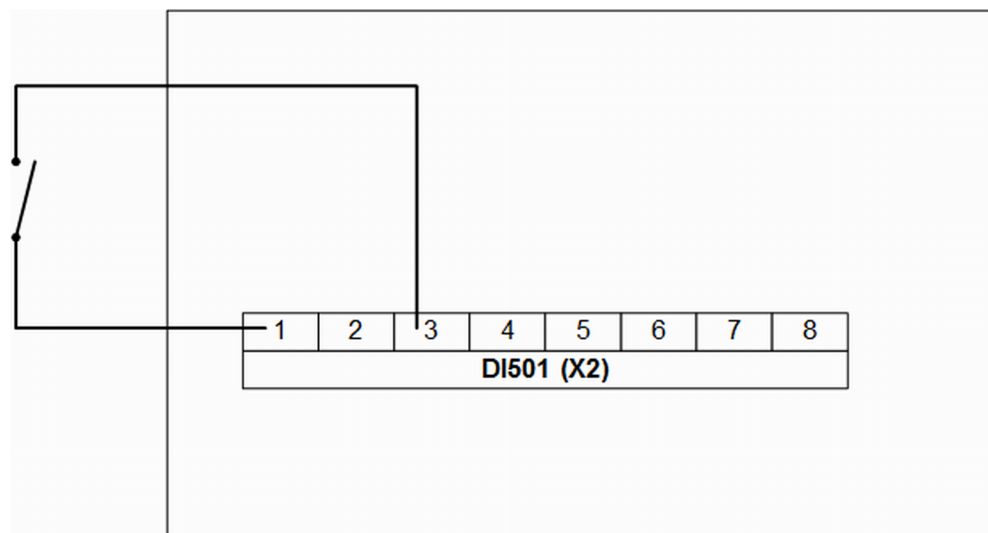

Fig. 72: Connection example: digital input (X2)

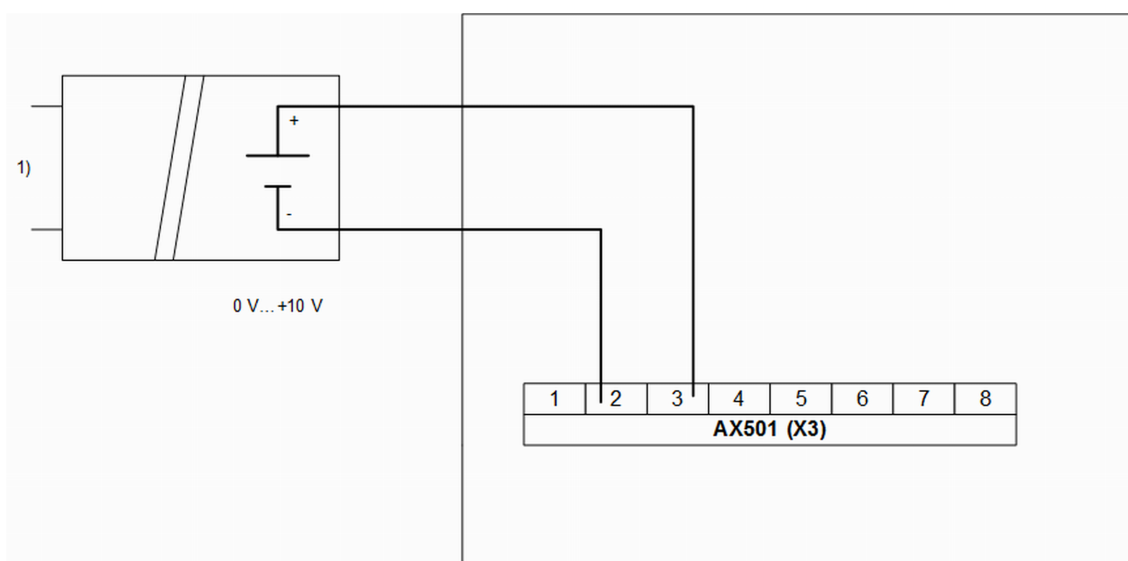

Fig. 73: Connection example: Voltage input

1) Galvanically isolated power supply of analog sensor.

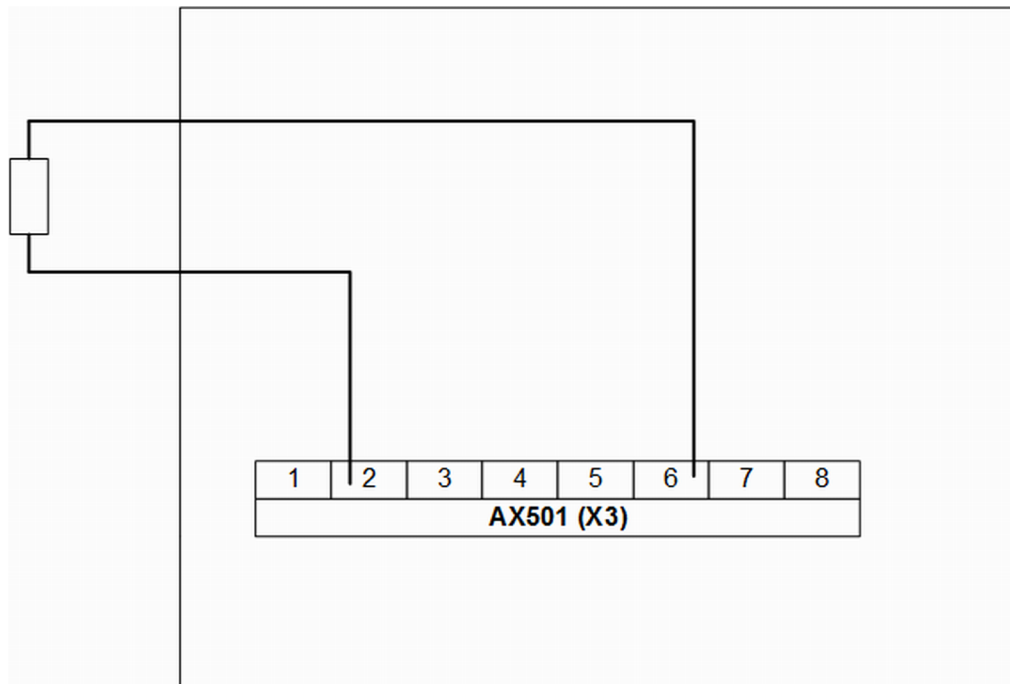

Fig. 74: Connection example: Voltage output



Analog signal lines must be routed in shielded cables. The shield must be grounded on both sides and should be grounded to replacement device and signal source / signal sink as close as possible.



CAUTION!

System damage caused by voltage!

The exchange of a replacement device under voltage can cause permanent system damage (destruction).

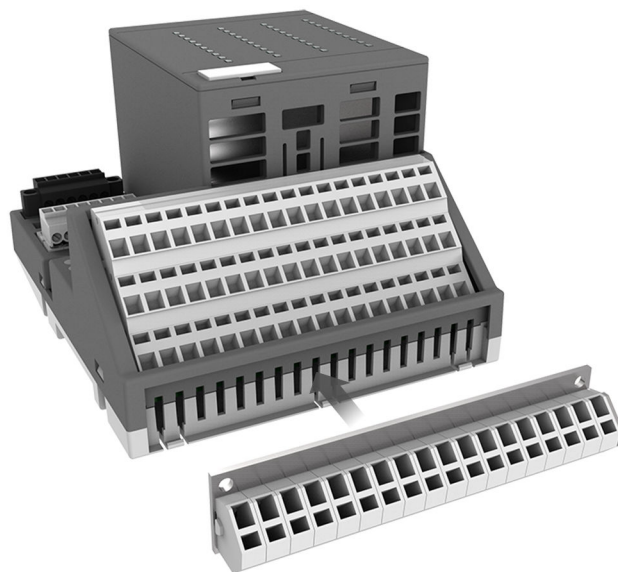

Fig. 75: Plug-in power bus

A power bus can be plugged into the replacement device. The contacts of the power bus have no connection to the electronic system of the replacement device. Furthermore, no FE connection is available.

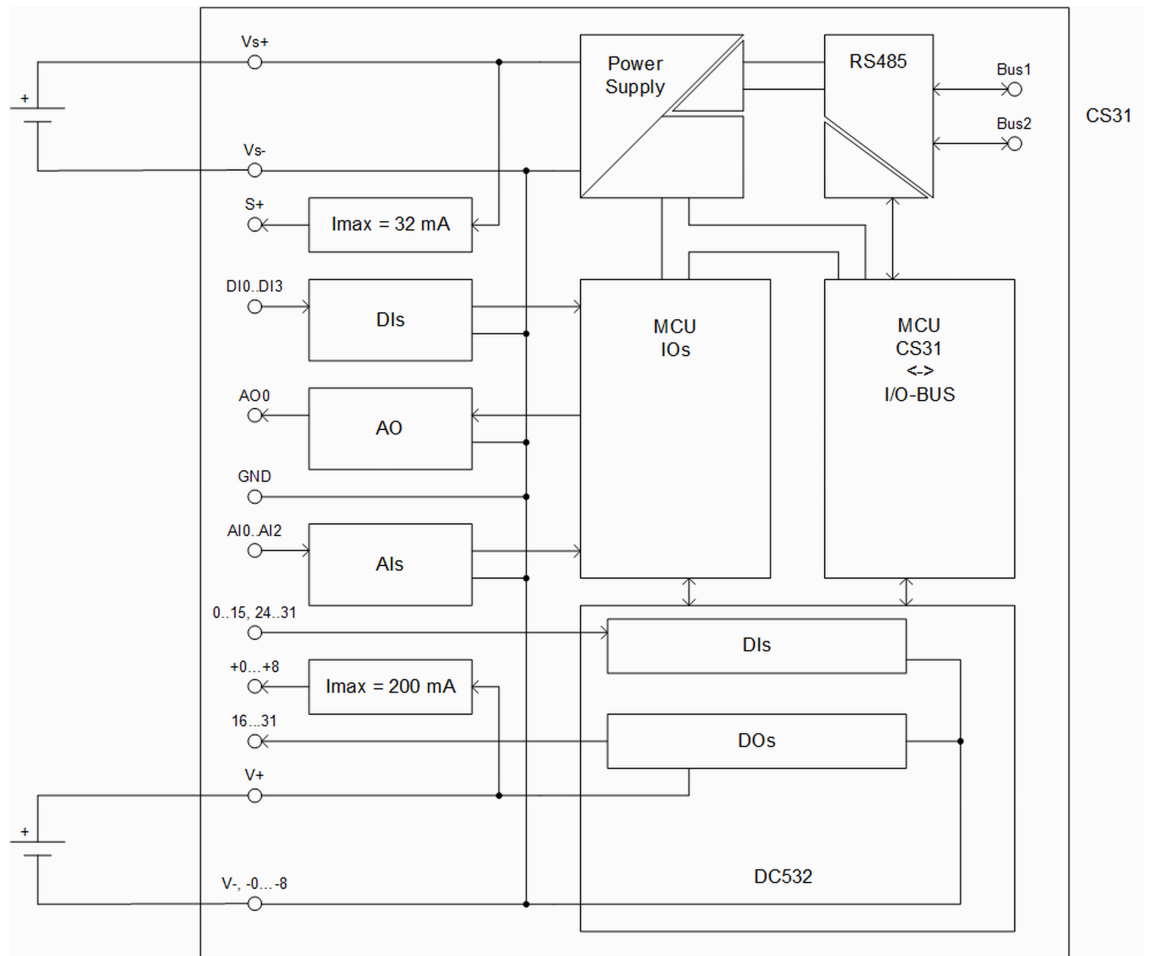

Fig. 76: Schematic diagram

For further information on grounding of the individual connections as well as shielding, please refer to [Chapter 1.3 “System data and CS31 bus system data”](#) on page 4.

1.5.6.2.3 Addressing

In the existing device, the address DIP switch was arranged on the top right of the device. In the replacement device, this DIP switch is located on the left side of the device.

An additional DIP switch (SEL) has been implemented for the selection of the extension (AX501, 3AI1AO or DI501/4DI). Please note that only one extension at a time can be used.

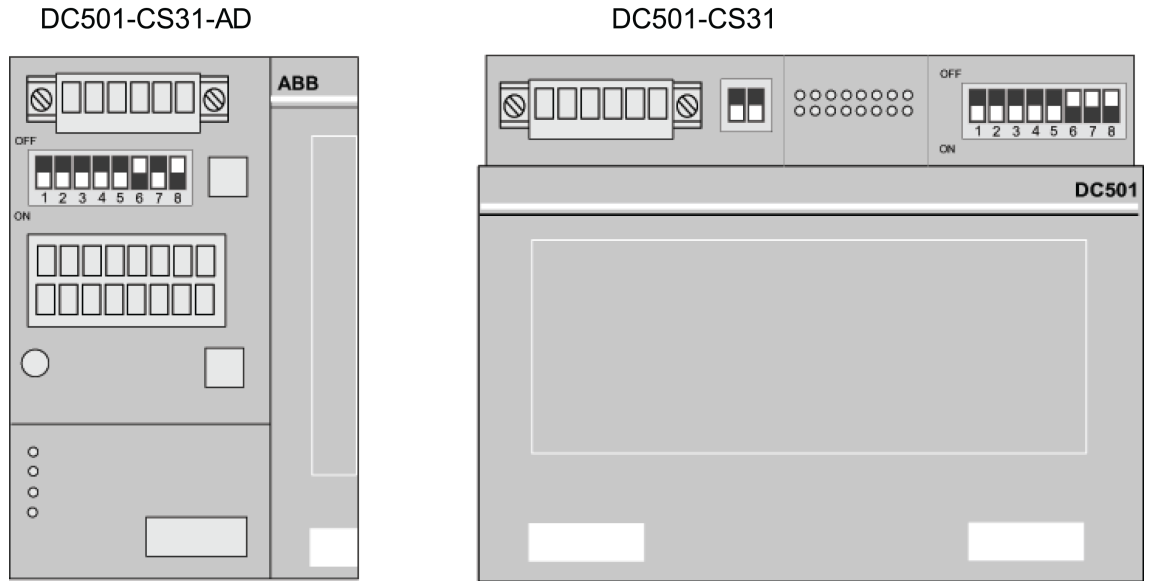

Fig. 77: DIP switch for DC501-CS31-AD



 The function of the address DIP switch 1 (channel switch) available in the existing device is no longer supported. This DIP switch must be switched off.

Table 87: Extension DIP switch (SEL)

S1	S2	Description
OFF	OFF	Normal, without extension
OFF	ON	Normal, with 3AI1AO/ AX501 extension
ON	OFF	Normal, with 4DI/ DI501 extension
ON	ON	Version DC501R0100, without extension

The device version DC501R0100 differs only in the data format of the CS31 bus. Further information, see Chapter 1.3.2 “CS31 bus system data” on page 10.

 The DIP switches are read by the device only once after the supply voltage has been connected.

 For further information, please refer to the existing documentation System description Advant Controller 31.

In the following, the information in the "Type" column refers to the data type designation of the Automation Builder (see AC31 system data see Chapter 1.3 “System data and CS31 bus system data” on page 4). The information in the "Type" column must be interpreted from the viewpoint of the CS31 bus master. The information in brackets must be interpreted from the viewpoint of the replacement device (CS31 bus slave).

Table 88: CS31 bus: 16 DI and 16 DO, normal and version DC501R0100

Byte	Type	Bit	Connector / Terminal
1	8 bit input (send)	0 ... 7	X4 / 00 ... 07
2	8 bit input (send)	0 ... 7	X4 / 08 ... 15
3	8 bit output (receive)	0 ... 7	X4 / 16 ... 23
4	8 bit output (receive)	0 ... 7	X4 / 24 ... 31

Table 89: CS31 bus: 24 DI and 16 DO, normal

Byte	Type	Bit	Connector / Terminal
1	8 bit input (send)	0 ... 7	X4 / 00 ... 07
2	8 bit input (send)	0 ... 7	X4 / 08 ... 15
3	8 bit input (send)	0 ... 7	X4 / 24 ... 31
4	8 bit input (send, filling byte)	0 ... 7	-
5	8 bit output (receive)	0 ... 7	X4 / 16 ... 23
6	8 bit output (receive)	0 ... 7	X4 / 24 ... 31

Table 90: CS31 bus: 24 DI and 16 DO, version DC501R0100

Byte	Type	Bit	Connector / Terminal
1	8 bit input (send)	0 ... 7	X4 / 00 ... 07
2	8 bit input (send)	0 ... 7	X4 / 08 ... 15
3	8 bit output (receive)	0 ... 7	X4 / 16 ... 23
4	8 bit input (send)	0 ... 7	X4 / 24 ... 31
5	8 bit output (receive)	0 ... 7	X4 / 24 ... 31

Table 91: CS31 bus: 16 DI, 16 DO, 3AI1AO, normal

Byte	Type	Bit	Connector / Terminal
1	8 bit input (send)	0 ... 7	X4 / 00 ... 07
2	8 bit input (send)	0 ... 7	X4 / 08 ... 15
3	8 bit input (send)	0 ... 7	X3 / 3
4	8 bit input (send)	0 ... 7	X3 / 4
5	8 bit input (send)	0 ... 7	X3 / 5
6	8 bit output (receive)	0 ... 7	X4 / 16 ... 23
7	8 bit output (receive)	0 ... 7	X4 / 24 ... 31
8	8 bit output (receive)	0 ... 7	X3 / 6

Table 92: CS31 bus: 16 DI, 16 DO, 4 DI, normal

Byte	Type	Bit	Connector / Terminal
1	8 bit input (send)	0 ... 7	X4 / 00 ... 07
2	8 bit input (send)	0 ... 7	X4 / 08 ... 15
3	8 bit input (send)	0 ... 3	X2 / 3 ... 6
	8 bit input (send)	4 ... 7	-

Byte	Type	Bit	Connector / Terminal
4	8 bit output (receive)	0 ... 7	X4 / 16 ... 23
5	8 bit output (receive)	0 ... 7	X4 / 24 ... 31

Table 93: CS31 bus: 24 DI, 16 DO, 3AI1AO, normal

Byte	Type	Bit	Connector / Terminal
1	8 bit input (send)	0 ... 7	X4 / 00 ... 07
2	8 bit input (send)	0 ... 7	X4 / 08 ... 15
3	8 bit input (send)	0 ... 7	X4 / 24 ... 31
4	8 bit input (send, filling byte)	0 ... 7	-
5	8 bit input (send)	0 ... 7	X3 / 3
6	8 bit input (send)	0 ... 7	X3 / 4
7	8 bit input (send)	0 ... 7	X3 / 5
8	8 bit input (send, filling byte)	0 ... 7	-
9	8 bit output (receive)	0 ... 7	X4 / 16 ... 23
10	8 bit output (receive)	0 ... 7	X4 / 24 ... 31
11	8 bit output (receive)	0 ... 7	X3 / 6
12	8 bit output (receive, filling byte)	0 ... 7	-

Table 94: CS31 bus: 24 DI, 16 DO, 4 DI, normal

Byte	Type	Bit	Connector / Terminal
1	8 bit input (send)	0 ... 7	X4 / 00 ... 07
2	8 bit input (send)	0 ... 7	X4 / 08 ... 15
3	8 bit input (send)	0 ... 7	X4 / 24 ... 31
4	8 bit input (send, filling byte)	0...7	-
5	8 bit input (send)	0 ... 3	X2 / 3 ... 6
		4 ... 7	-
6	8 bit input (send, filling byte)	0 ... 7	-
7	8 bit output (receive)	0 ... 7	X4 / 16 ... 23
8	8 bit output (receive)	0 ... 7	X4 / 24 ... 31

Table 95: CS31 bus: analog values

Nominal range 0...+10 V	Digital value (decimal)	Digital value (hexadecimal)
9.961 V	255	FF
9.922 V	254	FE
...
0.039 V	1	01
0.000 V	0	00

Relationship between analog voltage and digital representation (applies to analog inputs and analog output):

$$U_{\text{Signal}} = U_{\text{Ref}} \cdot \frac{\text{Digital value}_{8 \text{ Bit}}}{256}$$

$$U_{\text{Ref}} = 10 \text{ V}$$

Fig. 78: Formula: Voltage

 **Documentation change**
 The replacement device does not have an I/O bus. Communication interface module cannot be connected. For this reason, chapter "1.1.3 Addressing" of the technical description of DC501-CS31 concerning the expansion modules (e.g. DX511, DI511, DO511, AX511, AI511, AI512) is not valid for the replacement device. Possible data structures for the replacement device are indicated in the following table.

1.5.6.2.4 Behavior during normal operation

Interpretation of the LEDs:

- The device initializes automatically after the supply voltage is switched on. During this time, the S-ERR LED flashes.
- The PWR LED lights up as soon as the internal supply voltage of the device is present.
- After successful initialization of the I/O bus communication to the S500 module, the I/O bus LED lights up.
- After successful initialization of the CS31 bus communication, the CS31 bus LED lights up. The S-ERR LED goes out.
- During operation, the yellow LEDs indicate the signal states of the channels.

The RAM is checked during the initialization of the device. In addition, the firmware in the flash memory is checked by means of a checksum during initialization. When the control system (PLC/central unit) is stopped during normal operation, the outputs of the device are switched off. The inputs remain active. The outputs are also switched off in case of a malfunction of the CS31 bus.

1.5.6.2.5 Diagnosis and display

The replacement device transmits diagnosis information also via the CS31 bus.

Table 96: Diagnosis information CS31 bus

Error description	Channel	Error code (CODESYS)	Error code (CS31 bus)	Description
Device error	0	43	1	Internal error
Device error	1	45	2	No supply voltage V+ available
Channel error	0...15	46	4	Overload or short circuit on a digital output



The error codes that are transferred by the replacement device via the CS31 bus are newly displayed in CODESYS. Each error code of the CS31 bus (table column 3) produces the error code in CODESYS (table column 2). As a result, it is possible to operate the replacement device with a new control system (PLC/control unit), e.g. 07KT98-ARC-AD, as well as with an old control system (PLC/central unit), e.g. 07KT98.

Since in the replacement device the functionality of the extension box is integrated in the hardware, error code 6 (failure of extension box) does not occur.

The input/output functions of the extensions (AX501/ 3AI1AO, DI501/ 4DI) have no diagnoses.

Table 97: Device LEDs

LED	Status	Color	LED off	LED on	LED flashes
PWR	Voltage supply	Green	No internal supply voltage	Internal supply voltage	-
CS31 bus	CS31 bus communication	Green	No CS31 bus communication	CS31 bus communication	Only diagnosis, no data transfer. Transmission is disturbed.
S-ERR	Error	Red	No error	Static error (must be confirmed by the control system)	No CS31 bus connection or activity
I/O bus	I/O bus communication	Green	No I/O bus communication	I/O bus communication	Error I/O bus communication

The S-ERR LED remains on even if the error no longer occurs. The error must be confirmed by the control system (PLC/central unit), e.g. by means of a function block  Chapter 1.3 “System data and CS31 bus system data” on page 4.

Special cases with rapidly flashing LEDs (approx. 5 Hz):

- All 4 LEDs flash rapidly: An incorrect S500 module is connected to the device. The device fails to initialize.
- The LEDs of the CS31 bus, S-ERR bus and I/O bus flash rapidly: Invalid position of DIP switches. The device fails to initialize.
- The LEDs of the S-ERR bus and I/O bus flash rapidly: A checksum error occurred in an internal flash memory.
- The LED of the I/O bus flashes rapidly: An error occurred in an internal RAM.

Table 98: S500 module DC532 LEDs

LED	Status	Color	LED off	LED on	LED flashes
I0...I7 (see No. 1 in the following figure)	Digital inputs	Yellow	Input is not activated	Input is activated (input voltage is indicated even if supply is switched off)	-
I8...I15 (see No. 2 in the following figure)	Digital inputs	Yellow	Input is not activated	Input is activated (input voltage is indicated even if supply is switched off)	-
C16...C23 (see No. 3 in the following figure)	Digital outputs	Yellow	Output is not activated	Output is activated	-

LED	Status	Color	LED off	LED on	LED flashes
C24...C31 (see No. 4 in the following figure)	Digital inputs or digital outputs	Yellow	Input or output is not activated	Input/output is activated (input voltage is indicated even if supply is switched off)	-
Indication supply voltage (see No. 6 in the following figure)	Process voltage	Green	Process voltage not available	Process voltage OK	-
Error indications left (see No. 5 in the following figure)	Error indication	Red	No error	Internal error	
Error indications right (see No. 5 in the following figure)	Error indication	Red	No error	Internal error	Overload or short circuit on a channel of the corresponding group

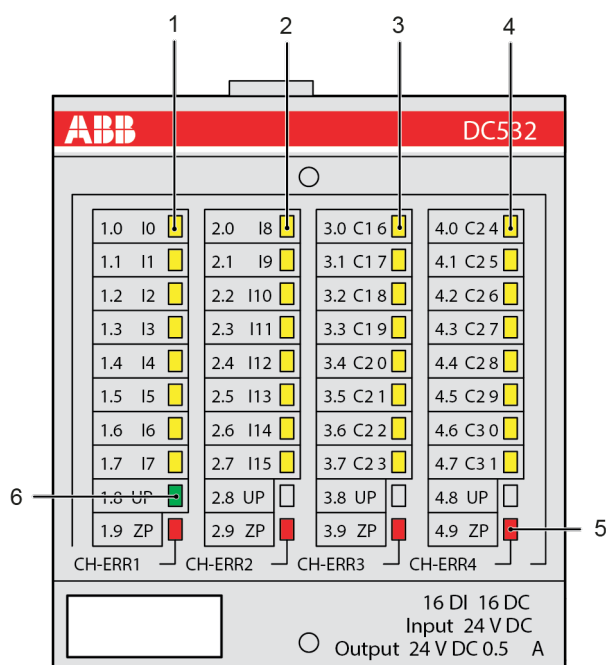

Fig. 79: Front view: DC532

1.5.6.2.6 Technical data

This section expands the details provided in the chapter [Chapter 1.3 “System data and CS31 bus system data” on page 4](#) and contains information on electromagnetic compatibility. The conformity is described in the declaration of conformity, which is available on the ABB website.



To ensure proper function of the replacement device DC501-CS31-AD, both supply voltages V_{s+} and V_+ must be applied.

Technical data of the complete device

Table 99: Supply voltage Vs

Data	Value
Process voltage: Fuse for Vs+	10 A, fast acting
Current consumption:	
-> via Vs+	Replacement device: 0.15 A Existing device DC501-CS31: approx. 60 ... 230 mA
- Inrush current via Vs+ (when voltage is switched on)	0.06 A ² s
Power consumption	5 W



For further information, please refer to the existing documentation [System description Advant Controller 31](#).



CAUTION!

System damage caused by voltage!

Exceeding the maximum supply or process voltage (>30 V DC) results in permanent system damage (destruction).

Table 100: Supply voltage V

Data	Value
Process voltage:	
-> Fuse for V+	10 A, fast acting
-> Additional V-/Vs- connections (GND)	X4 / -0, X4 / -1, X4 / -2, X4 / -3, X4 / -4, X4 / -5, X4 / -6, X4 / -7, X4 / -8
Current consumption:	
-> via V+	Replacement device: 0.15 A incl. load current Existing device DC501-CS31: approx. 100 mA without load current
- Inrush current via V+ (when voltage is switched on)	0.013 A ² s
Power consumption	220 W
Power consumption outputs unloaded	6 W
Sensor supply voltage connections	X4 / +0, X4 / +1, X4 / +2, X4 / +3, X4 / +4, X4 / +5, X4 / +6, X4 / +7, X4 / +8
Current sensor supply voltage (all connections combined)	Replacement device: max. 200 mA Existing device DC501-CS31: Microfuse 8 A, fast acting *)

*) The existing device contained an 8 A fuse to be exchanged by the user. The replacement device has an integrated electronic current limiter instead.



For further information, please refer to the existing documentation System description Advant Controller 31.



CAUTION!

System damage caused by voltage!

Exceeding the maximum supply or process voltage (>30 V DC) results in permanent system damage (destruction).

Connection to the CS31 bus

Data	Value
Connections	X1 / 3, X1 / 4
CS31 bus type	04 (digital input/output)

Expansion interface

The replacement device does not have an expansion interface.

Interface extension box

Table 101: Analog inputs

Data	Value
Number of channels	3
Connections	X3 / 3, X3 / 4, X3 / 5
Reference connections (GND)	X3 / 2, X3 / 7
Type of inputs	Voltage unipolar
Galvanic isolation	Not available
Nominal range	0...10 V
Input resistance per channel	Replacement device: > 100 kΩ Existing device AX501: 95 kΩ
Time constant of the input filter	Replacement device: approx. 8 ms Existing device AX501: approx. 7 ms
Total errors (due to non-linearity, offset, resolution and temperature)	Replacement device: max. 3 % Existing device AX501: 0.6 % ± 1 digit ± 150 ppm/K
Indication of the input signals	Replacement device: not available Existing device AX501: green LED per channel
Conversion cycle *)	Replacement device: 1.5 ms for all three channels Existing device AX501: 1.64 ms for all three channels
Conversion process	Successive approximation

Data	Value
Averaging of measured values	not available
Resolution	8 bit
Unused voltage inputs	Can remain open or be short-circuited after GND or V+ to increase noise immunity
Overvoltage protection	Available
Overload range	± 30 V DC
Max. line length of analog lines, line cross section > 0.14 mm ²	100 m

*) Conversion cycle of MCU of I/O processing. The transmission via serial buses is slower.



For further information, please refer to the existing documentation [System description Advant Controller 31](#).

Table 102: Analog output

Data	Value
Number of channels	1
Connections	X3 / 6
Reference connections (GND)	X3 / 2, X3 / 7
Type of outputs	Voltage unipolar
Galvanic isolation	not available
Nominal range	0 ... 10 V
Output load capability	max. ± 5 mA
Indication of the output signals	Replacement device: Not available Existing device AX501: green LED per channel
Resolution	8 bit
Total errors (due to non-linearity, offset, resolution and temperature)	Replacement device: max. 3 % Existing device AX501: 0.6 % ± 1 digit ± 150 ppm/K
Update cycle	1.5 ms
Unused output	remains unconnected
Short-circuit-proof	Yes *)
External supply protection	Up to +30 V DC (no external supply protection available for negative voltages!)
Max. line length of analog lines, line cross section > 0.14 mm ²	100 m



For further information, please refer to the existing documentation [System description Advant Controller 31](#).



CAUTION!

System damage caused by short-circuit!

*) A short-circuit can result in up to 2 W additional power dissipation in the device. If this power dissipation cannot be discharged, the replacement device can be damaged.

Table 103: Digital inputs

Data	Value
Number of channels	4
Connections	X2 / 3, X2 / 4, X2 / 5, X2 / 6
Reference connection (GND)	X4 / Vs-
Connections switch supply	X2 / 1, X2 / 2, X2 / 7, X2 / 8
Current switch supply (all connections combined)	Replacement device: max. 32 mA Existing device DI501: max. 30 mA
Input type according to EN 61131-2	Type 1
Galvanic isolation	Not available
Indication of the input signals	Replacement device: Not available Existing device DI501: green LED per channel
Input delay (0->1 or 1->0)	Typ. 3 ms
Scanning cycle	500 µs
Input signal voltage:	
-	24 V DC
-> 0 signal	Replacement device: -3 V ... +5 V Existing device DI501: -30 V ... +5 V
-> Undefined signal	Replacement device: > +5 V ... < +15 V Existing device DI501: > +5 V ... < +13 V
-> 1 signal	Replacement device: +15 V ... +30 V Existing device DI501: +13 V ... +30 V
-> Residual ripple at 0 signal	Within -3 V ... +5 V
-> Residual ripple at 1 signal	Within +15 V ... +30 V
Input current per channel:	
-> Input voltage +24 V	Typ. 5.5 mA
-> Input voltage +5 V	≥ 0.5 mA
-> Input voltage +15 V	≥ 2 mA
-> Input voltage +30 V	≤ 8 mA
Maximum cable length:	
-> Shielded	1000 m
-> Unshielded	600 m
Overvoltage protection	Available
Overload range	±30 V DC



For further information, please refer to the existing documentation System description Advant Controller 31.

Inputs 24 V DC

Data	Value
Connections	X4 / 00, X4 / 01, X4 / 02, X4 / 03, X4 / 04, X4 / 05, X4 / 06, X4 / 07, X4 / 08, X4 / 09, X4 / 10, X4 / 11, X4 / 12, X4 / 13, X4 / 14, X4 / 15, X4 / 24, X4 / 25, X4 / 26, X4 / 27, X4 / 28, X4 / 29, X4 / 30, X4 / 31
Input type according to EN 61131-2	Type 1
Galvanic isolation	Not available
Status display	Replacement device: 1 yellow LED per input Existing device DC501-CS31: 1 green LED per input
Input delay (0-> 1 or 1-> 0)	Replacement device: Typ. 8 ms Existing device DC501-CS31: Typ. 3 ms
Input signal voltage:	
-	24 V DC
-> 0 signal	Replacement device: -3 V ... +5 V Existing device DC501-CS31: -30 V ... +5 V
-> Undefined signal	Replacement device: > +5 V ... < +15 V Existing device DC501-CS31: > +5 V ... < +13 V
-> 1 signal	Replacement device: +15 V ... +30 V Existing device DC501-CS31: +13 V ... +30 V
-> Residual ripple at 0 signal	Within -3 V ... +5 V
-> Residual ripple at 1 signal	Within +15 V ... +30 V
Input current per channel:	
-> Input voltage +24 V	Replacement device: typ. 5 mA Existing device DC501-CS31: typ. 4 mA
-> Input voltage +5 V	> 1 mA
-> Input voltage +15 V	> 5 mA
-> Input voltage +30 V	< 8 mA
Maximum cable length:	
-> Shielded	1000 m
-> Unshielded	600 m
Overvoltage protection	Up to 30 V DC
Marking	Replacement device: not possible Existing device DC501-CS31: with label strip possible



For further information, please refer to the existing documentation System description Advant Controller 31.

Outputs 24 V DC

Data	Value
Connections	X4 / 16, X4 / 17, X4 / 18, X4 / 19, X4 / 20, X4 / 21, X4 / 22, X4 / 23, X4 / 24, X4 / 25, X4 / 26, X4 / 27, X4 / 28, X4 / 29, X4 / 30, X4 / 31
Type of digital outputs	High-side switches
Demagnetization with inductive load	Via internal varistor (see following figure)
Status display	Replacement device: 1 yellow LED per output Existing device DC501-CS31: 1 green LED per output
Output delay (0-> 1 or 1-> 0)	On request
Switching frequency:	
-> With ohmic load	Replacement device: on request Existing device DC501-CS31: ≤ 100 Hz
-> With inductive load	Replacement device: max. 0.5 Hz Existing device DC501-CS31: ≤ 2 Hz
-> With lamp load	Replacement device: max. 11 Hz at max. 5 W Existing device DC501-CS31: ≤ 10 Hz at max. 5 W
Inductive cut-off voltage	Replacement device: Typ. -67 V Existing device DC501-CS31: Typ. (voltage V) -55 V
Maximum cable length:	
-> Shielded	1000 m
-> Unshielded	600 m
Marking	Replacement device: not possible Existing device DC501-CS31: with label strip possible



For further information, please refer to the existing documentation System description Advant Controller 31.

The following figure shows the circuitry of a digital input/output with the varistors for demagnetization when switching off inductive loads.

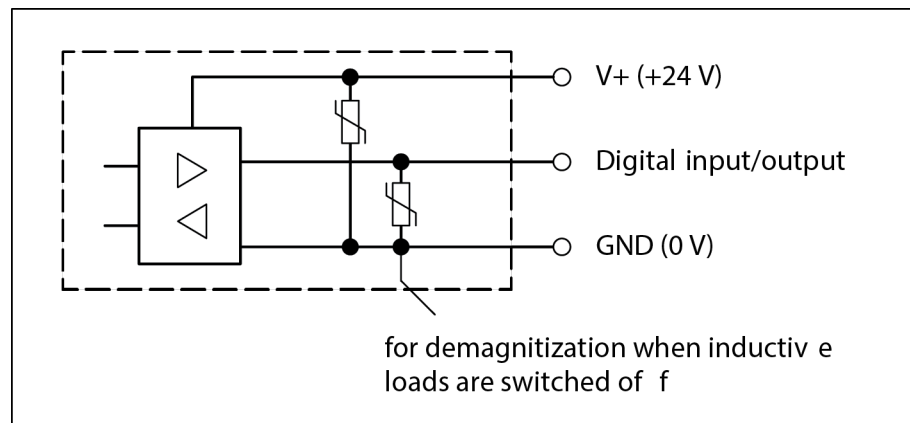

Fig. 80: Protective circuits inputs/outputs



When the channels of X4 / 24 to X4 / 31 are to be used as inputs, the respective outputs (high-end switches) must be switched off.

Mechanical data

Data	Value
Width x height x depth	Replacement device: 104 x 118 x 75.1 mm Existing device DC501-CS31: 102 x 112 x 77 mm
Weight	Replacement device: 354 g Existing device DC501-CS31: approx. 150 g
Dimensions for mounting	See operating and assembly instructions of the replacement device: 3ADR020087M0401

Mounting information

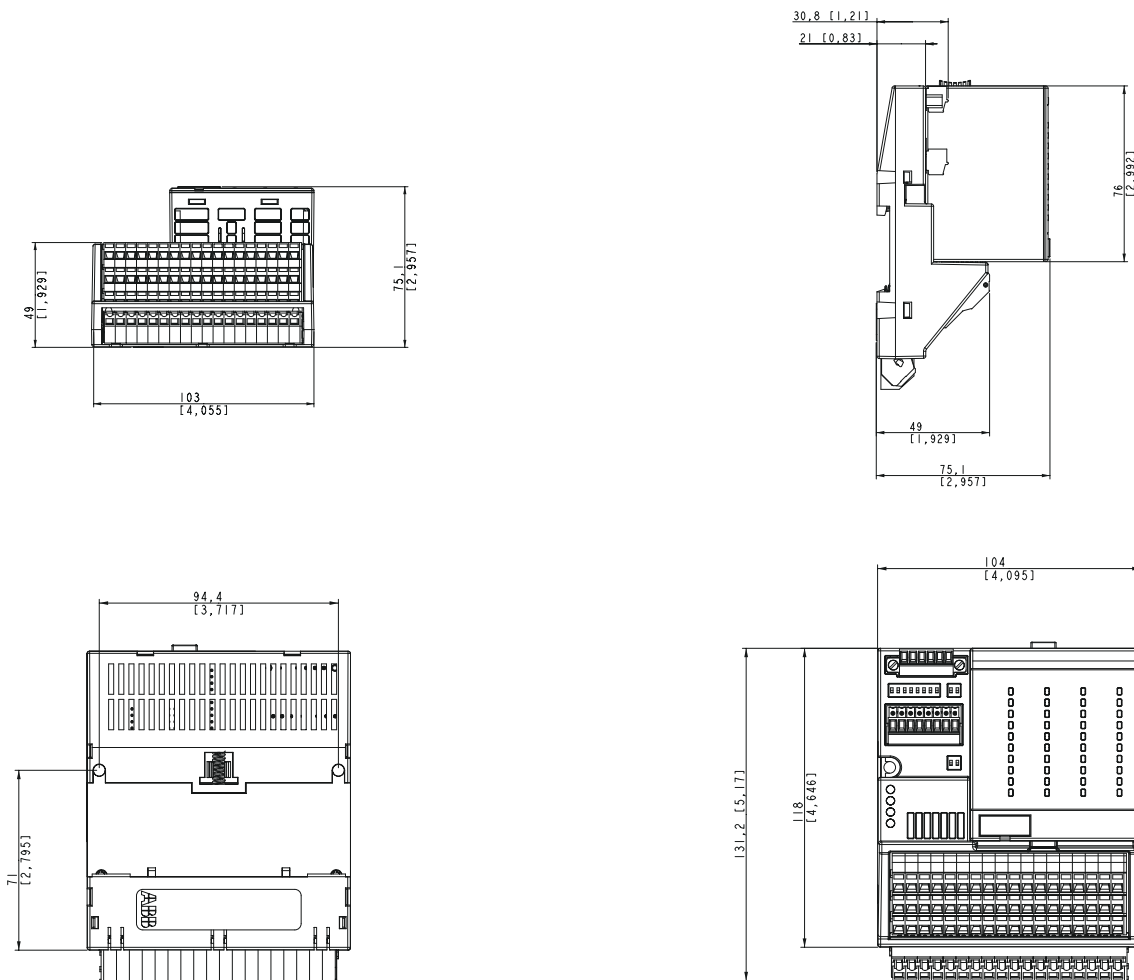

The dimensions are in mm and in brackets in inch.



CAUTION!

System damage caused by voltage!

The exchange of a replacement device under voltage can cause permanent system damage (destruction).

Data	Value
Mounting position	Vertical, terminal block facing downward
Cooling	The natural convection cooling must not be hindered by cable ducts or other switchgear cabinet equipment (clearance between cable duct and device at least 20 mm).

Ordering data

Order No.	Scope of delivery
1SAP 800 400 R0010	Communication interface module CS31 16 DI, 8 DC, 8 DO, DC501-CS31-AD 1 6-pole terminal block 2 8-pole terminal blocks

2 Index

1, 2, 3 ...

07AC91-AD

Addressing	67
Analog outputs	71
Binary input	71
Configuration	66
Connections	63
CS31 bus	72
CS31 system bus	72
Device configuration	61
Diagnosis and display	68
Electrical connection	63
LED display	61, 112
Measuring ranges	67
Mechanical data	72
Normal operation	68
Ordering data	74
Technical data	70

07AC91-AD2

Addressing	83
Analog inputs	88
Analog outputs	89
Binary input	88
Configuration	82
connection	76
CS31 bus	89
CS31 system bus	89
Device configuration	75
Diagnosis and display	85
Electrical connection	76
LED display	76
Measuring ranges	83
Mechanical data	90
Normal operation	84
Ordering data	91
Technical data	87

07AC92-AD

LED display	128
-------------	-----

07AI91-AD

Addressing	101
Analog inputs	106
Analog voltage input	106

Configuration	98
connection	94
CS31 bus	108
CS31 system bus	108
Current input	107
Device configuration	92
Diagnosis and display	102, 119, 134
Electrical connection	94
LED display	93
Measuring ranges	99
Mechanical data	108
Normal operation	68, 84, 102, 118, 133, 156
Ordering data	110
Pt100/Pt1000 input	107

07DC91-AD

Addressing	116
Configurable inputs / outputs	123
Configuration	118
connection	113
CS31 bus	124
CS31 system bus	124
Device configuration	111
Diagnosis and display	119
Digital inputs	122
Digital outputs	123
Electrical connection	113
Mechanical data	124
Normal operation	119
Ordering data	126

07DC92-AD

Addressing	132
Configuration	133
connection	129
CS31 bus	141
CS31 system bus	141
Device configuration	127
Diagnosis and display	134
Digital inputs	138
Digital outputs	140
Electrical connection	129
Mechanical data	141
Ordering data	142

A		C	
AC31		C31 system bus:	
adapter	3	Central unit 07KT98	27
Creepage distances and clearances	5	Central unit 07KT9x-AD	46
Electromagnetic compatibility	6	Analog inputs	51
Mechanical data	7	Analog outputs	52
Operating and environmental conditions	4	COM2 interfaces	53
Power Supply Units	6	CS31 bus	54
system data	4	CS31 system bus	54
Test voltages	5	Digital inputs	47
AC31 System data		Digital inputs/outputs	49
Grounding	7	Digital outputs	48
Addressing		High-speed hardware counter	55
07AC91-AD	67	LED display	55
07AC91-AD2	83	Lithium battery	47
07AI91-AD	101	Mechanical data	56
07DC91-AD	116	Ordering data	56
07DC92-AD	132	Technical data	45
DC501-CS31-AD	152	Central unit 07KT98	
Analog current input		Analog inputs	34
07AI91-AD	107	Analog outputs	42
Analog inputs		Battery	43
07AC91-AD2	88	C31 system bus:	27
07AI91-AD	106	connection	26
Central unit 07KT9x-AD	51	connections	26
Central unit 07KT98	34	Device configuration	25
Analog outputs		Digital inputs	28
07AC91-AD	71	Digital inputs/outputs	31
07AC91-AD2	89	Digital outputs	30
Central unit 07KT9x-AD	52	Electrical connection	26
Central unit 07KT98	42	Functionality	22
Analog voltage input		High-speed counter	45
07AI91-AD	106	Interface COM1	43
ARCNET CM	56	Interface COM2	44
ARCNET communication module	56	network interface	44
Short description	57	networking interface	44
Technical data	56	Short description	21
ARCNET coupler	56	SmartMedia Card	44
Short description	57	Supply voltage	27
Technical data	56	Configurable inputs / outputs	
B		07DC91-AD	123
Battery		Configuration	
Central unit 07KT98	43	07AC91-AD	66
		07AC91-AD2	82

07AI91-AD	98	Electrical connection	146
07DC91-AD	118	Extension box	160
07DC92-AD	133	Inputs 24 V DC	163
connection		LED display	144
07AC91-AD2	76	Mechanical data	165
07AI91-AD	94	Normal operation	156
07DC91-AD	113	Ordering data	167
07DC92-AD	129	Outputs 24 V DC	164
Central unit 07KT98	26	Technical data	158
DC501-CS31-AD	146	Device configuration	
connections		07AC91-AD	61
07AC91-AD2	76	07AC91-AD2	75
07AI91-AD	94	07AI91-AD	92
07DC91-AD	113	07DC91-AD	111
07DC92-AD	129	07DC92-AD	127
DC501-CS31-AD	146	Central unit 07KT98	25
Connections		DC501-CS31-AD	144
07AC91-AD	63	Diagnosis and display	
CPU	20	07AC91-AD	68
CS31 bus		07AC91-AD2	85
Central unit 07KT9x-AD	54	07AI91-AD	102, 119, 134
CS31 bus system data	4	07DC91-AD	119
Bus cycle time	14	07DC92-AD	134
Bus topology	11	DC501-CS31-AD	156
Configuration	16	Digital inputs	
Diagnosis	17	07DC91-AD	122
Earthing	13	07DC92-AD	138
Grounding	13	Central unit 07KT9x-AD	47
Wiring	10	Central unit 07KT98	28
CS31 system bus		Digital inputs/outputs	
07AC91-AD	72	Central unit 07KT9x-AD	49
07AC91-AD2	89	Central unit 07KT98	31
07AI91-AD	108	Digital outputs	
07DC91-AD	124	07DC91-AD	123
07DC92-AD	141	07DC92-AD	140
DC501-CS31-AD	160	Central unit 07KT9x-AD	48
		Central unit 07KT98	30
D		E	
DC501-CS31-AD		Electrical connection	
Addressing	152	07AC91-AD	63
connection	146	07AC91-AD2	76
CS31 bus	160	07AI91-AD	94
CS31 system bus	160	07DC91-AD	113
Device configuration	144	07DC92-AD	129
Diagnosis and display	156		

Central unit 07KT98	26	07DC91-AD	124
DC501-CS31-AD	146	07DC92-AD	141
Ethernet communication module		Central unit 07KT9x-AD	56
Short description	58	DC501-CS31-AD	165
Technical data	58		
Ethernet coupler		N	
Short description	58	Normal operation	
Technical data	58	07AC91-AD	68
Extension box		07AC91-AD2	84
DC501-CS31-AD	160	07AI91-AD	68, 84, 102, 118, 133, 156
		07DC91-AD	119
H		DC501-CS31-AD	156
High-speed counter			
Central unit 07KT98	45	O	
High-speed hardware counter		Ordering data	
Central unit 07KT9x-AD	55	07AC91-AD	74
		07AC91-AD2	91
I		07AI91-AD	110
Inputs 24 V DC		07DC91-AD	126
DC501-CS31-AD	163	07DC92-AD	142
Interface COM1		Central unit 07KT9x-AD	56
Central unit 07KT98	43	DC501-CS31-AD	167
Interface COM2		Outputs 24 V DC	
Central unit 07KT98	44	DC501-CS31-AD	164
Introduction		Overview	3
Replacement devices for AC31	3		
		P	
L		PROFIBUS DP communication module	
LED display		Short description	57
07AC91-AD	61, 112	Technical data	57
07AC91-AD2	76	PROFIBUS DP coupler	
07AC92-AD	128	Short description	57
07AI91-AD	93	Technical data	57
Central unit 07KT9x-AD	55	Pt100/Pt1000 input	
DC501-CS31-AD	144	07AI91-AD	107
Lithium battery	47		
		R	
M		replacement device	
Measuring ranges		07AI91-AD	91
07AC91-AD	67	Replacement device	
07AC91-AD2	83	07AC91-AD2	74
07AI91-AD	99	07DC91-AD	110
Mechanical data		07DC92-AD	126
07AC91-AD	72	07KT9x-AD	20
07AC91-AD2	90	Replacement devices	
07AI91-AD	108	CS31 bus system data	10

Replacement unit	
DC501-CS31-AD	143

S

Short description	
ARCNET communication module	57
ARCNET coupler	57
Central unit 07KT98	21
Ethernet communication module	58
Ethernet coupler	58
PROFIBUS DP coupler	57
SmartMedia Card	44
Supply of devices	46
Supply voltage	
Central unit 07KT98	27
System data	4
Creepage distances and clearances	5
Earthing	7
Electromagnetic compatibility	6
Grounding	7
Mechanical data	7
Operating and environmental conditions	4
Power Supply Units	6
Test voltages	5
System data AC31 adapters	4

T

Technical data	70, 87, 105, 121, 136
07AC91-AD	70
07AC91-AD2	87
ARCNET communication module	56
Central unit 07KT9x-AD	45
DC501-CS31-AD	158
Ethernet communication module	58
PROFIBUS DP communication module	57
PROFIBUS DP coupler	57

ABB AG
Eppelheimer Str. 82
69123 Heidelberg, Germany
Telephone: +49 (0)6221 701 1444
E-mail: plc.support@de.abb.com
abb.com/plc
abb.com/automationbuilder
abb.com/contacts

© Copyright 2016-2022 ABB.
We reserve all rights in this document and in the information contained therein. Reproduction, use or disclosure to third parties without express authority is strictly forbidden.